

ebm-papst Mulfingen GmbH & Co. KG

Bachmühle 2 · D-74673 Mulfingen

Phone +49 7938 81-0

Fax +49 7938 81-110

info1@de.ebmpapst.com

www.ebmpapst.com

Limited partnership · Headquarters Mulfingen

Amtsgericht (court of registration) Stuttgart · HRA 590344

General partner Elektrobau Mulfingen GmbH · Headquarters Mulfingen

Amtsgericht (court of registration) Stuttgart · HRB 590142

Nominal data

Type	W1G250-HJ87-02	
Motor	M1G074-BF	
Nominal voltage	VDC	24
Nominal voltage range	VDC	16 .. 28
Method of obtaining data		fa
Speed (rpm)	min ⁻¹	3070
Power consumption	W	128
Current draw	A	7
Max. back pressure	Pa	150
Max. back pressure	in. wg	0.6
Min. ambient temperature	°C	-40
Max. ambient temperature	°C	60

ml = Max. load · me = Max. efficiency · fa = Free air · cs = Customer specification · ce = Customer equipment
Subject to change

Data according to Commission Regulation (EU) 327/2011

		Actual	Req. 2015
01 Overall efficiency η_{es}	%	41.6	28.1
02 Measurement category		A	
03 Efficiency category		Static	
04 Efficiency grade N		53.5	40
05 Variable speed drive		Yes	

Data obtained at optimum efficiency level.

The ErP data is determined using a motor-impeller combination in a standardized measurement setup.

09 Power consumption P_e	kW	0.13
09 Air flow q_v	m ³ /h	1355
09 Pressure increase p_{fs}	Pa	132
10 Speed (rpm) n	min ⁻¹	2745
11 Specific ratio [*]		1.00

^{*} Specific ratio = $1 + p_{fs} / 100\,000\text{ Pa}$

LU-156909



Technical description

Weight	2.35 kg
Size	250 mm
Motor size	74
Rotor surface	Galvanized
Electronics housing material	Die-cast aluminum, painted black
Impeller material	PP plastic
Fan housing material	Die-cast aluminum
Number of blades	7
Airflow direction	V
Direction of rotation	Counterclockwise, viewed toward rotor
Degree of protection	Motor IP24 KM, electronics IP6K9K
Insulation class	"B"
Moisture (F) / Environmental (H) protection class	H2+
Ambient temperature note	Occasional start-up between -40°C and -25°C is permissible. For continuous operation at temperatures below -25°C (e.g. refrigeration applications) we recommend our fan design with special low-temperature bearings.
Max. permitted ambient temp. for motor (transport/storage)	+70 °C
Min. permitted ambient temp. for motor (transport/storage)	-40 °C
Installation position	Shaft horizontal or rotor on bottom; rotor on top on request
Condensation drainage holes	On rotor side
Mode	S1
Motor bearing	Ball bearing; (sealed)
Technical features	<ul style="list-style-type: none"> - Tach output - Motor current limitation - Soft start - Control input 0-10 VDC / PWM - Overvoltage detection - Thermal overload protection for electronics
Electrical hookup	Via terminal strip
Motor protection	Reverse polarity and locked-rotor protection
Approval	UL 507; EAC

Product drawing

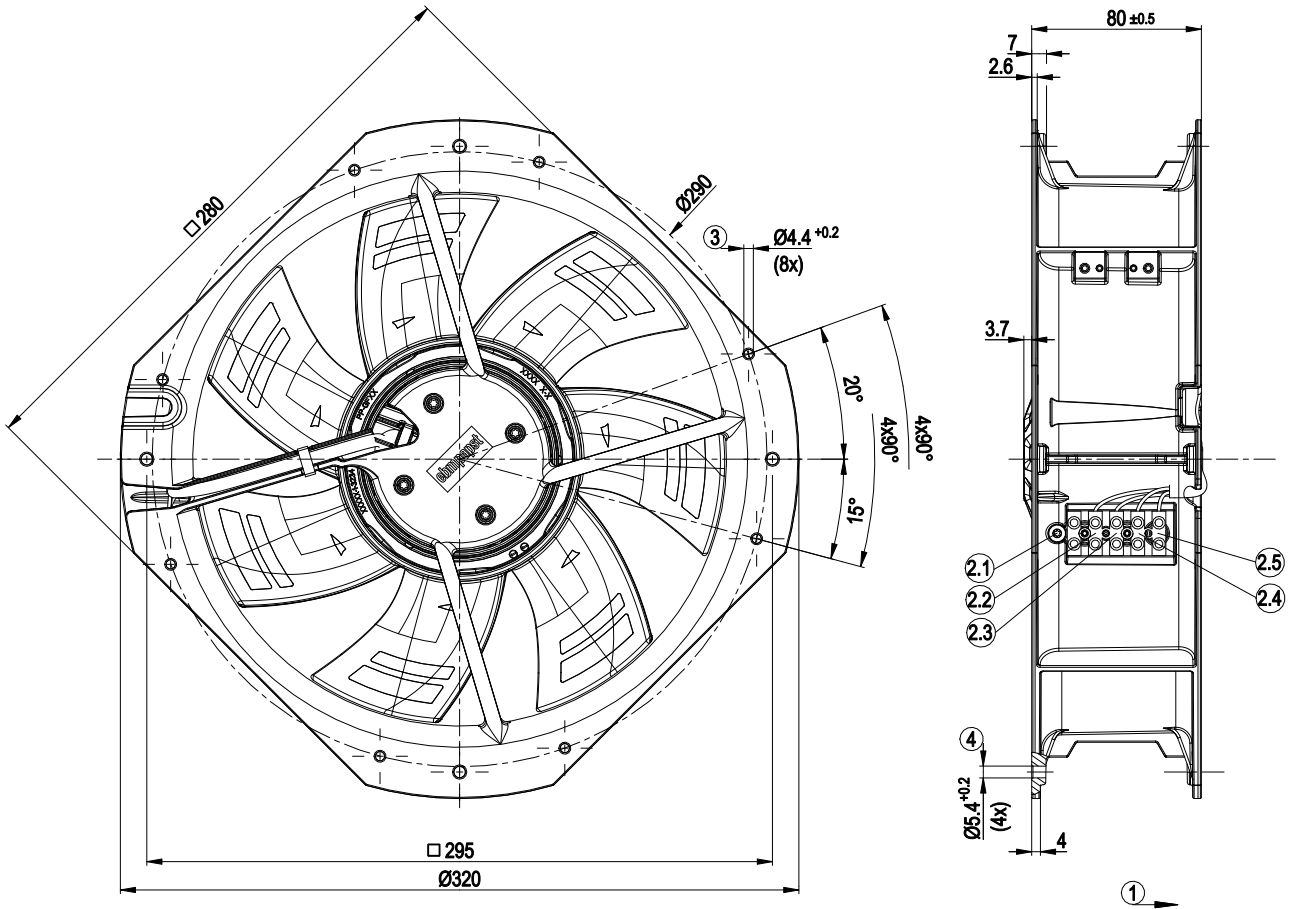

1	Direction of air flow "V"
2.1	Protective earth
2.2	Control input yellow
2.3	Speed monitoring white
2.4	(-) blue
2.5	(+) red
3	For self-tapping M5 screws
4	For self-tapping M6 screws

Connection diagram

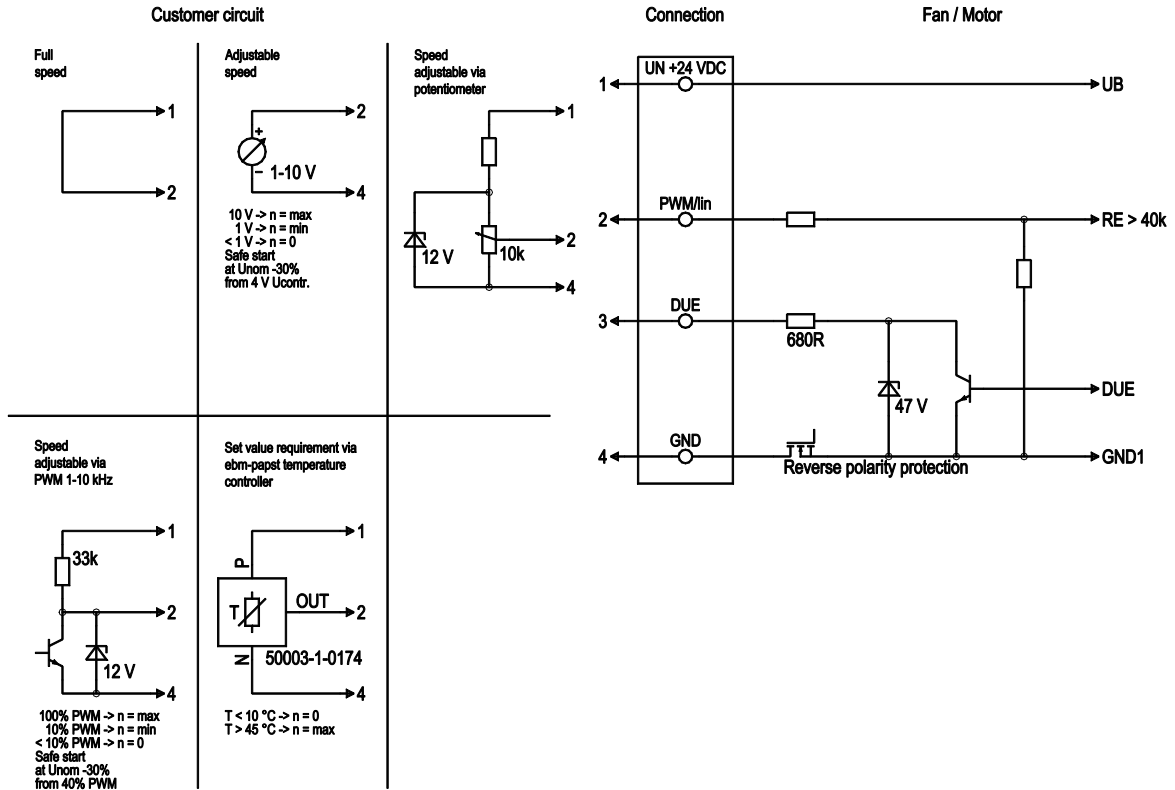

No.	Conn.	Designation	Color	Function/assignment
	1	UN +24 VDC	red	Power supply 24 VDC, maximum ripple 3.5%
	2	PWM/LIN	yellow	Control input Re > 40k
	3	DUE	white	Tach output, 3 pulses per revolution, Isink max = 10 mA
	4	GND	blue	Reference ground

Curves: Air performance

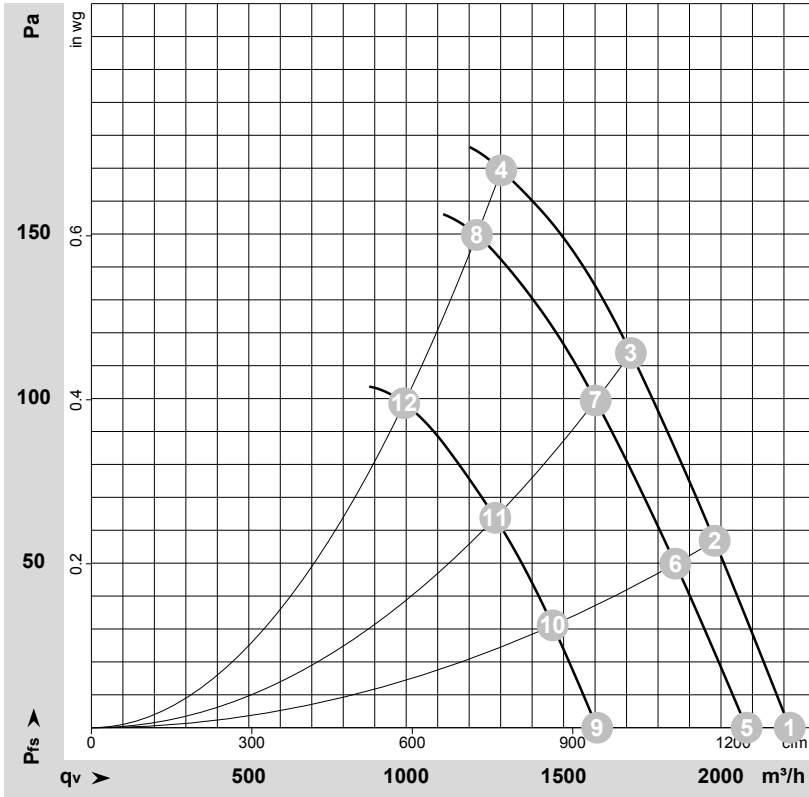

$\rho = 1.15 \text{ kg/m}^3 \pm 2 \%$

Measurement: LU-172450-1
 Measurement: LU-172294-1
 Measurement: LU-172449-1

Air performance measured according to ISO 5801 installation category A. For detailed information on the measurement setup, contact ebm-papst. Intake sound level: Sound power level according to ISO 13347 / sound pressure level measured at 1 m distance from fan axis. The values given are valid under the specified measuring conditions and may vary due to conditions of installation. For deviations from the standard configuration, the parameters have to be checked on the installed unit.

Measured values

	Wired	U	n	P _{ed}	I	LpA _{in}	LwA _{in}	q _v	P _{fs}	q _v	P _{fs}
		V	min ⁻¹	W	A	dB(A)	dB(A)	m ³ /h	Pa	cfm	in. wg
1	1~	28	3270	156	7.76			2220	0	1305	0.00
2	1~	28	3125	161	8.22			1980	57	1165	0.23
3	1~	28	2985	167	8.67			1715	114	1010	0.46
4	1~	28	2870	173	9.13			1300	169	765	0.68
5	1~	24	3070	128	7.00	66	74	2080	0	1225	0.00
6	1~	24	2935	131	7.35	66	73	1855	50	1090	0.20
7	1~	24	2805	135	7.74	65	72	1600	100	945	0.40
8	1~	24	2700	140	8.13	66	73	1225	150	720	0.60
9	1~	16	2405	61	4.84			1605	0	945	0.00
10	1~	16	2340	65	5.19			1465	31	860	0.12
11	1~	16	2270	70	5.57			1285	64	755	0.26
12	1~	16	2205	73	5.87			995	99	585	0.40

Wired = Wiring · U = Voltage · n = Speed (rpm) · P_{ed} = Power consumption · I = Current draw · LpA_{in} = Sound pressure level intake side · LwA_{in} = Sound power level intake side
 q_v = Air flow · P_{fs} = Pressure increase

