

EPR. | Flush pull handles

for screw mounting, technopolymer

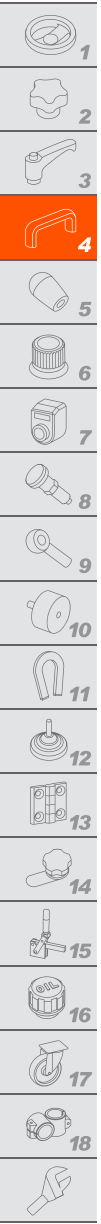

MATERIAL

Glass-fibre reinforced polyamide based (PA) technopolymer, grey-black colour, matte finish.

COVER

Technopolymer in Ergostyle colours, glossy finish, removable by a screwdriver by playing upon the central part (see drawing). Available also as accessory sold separately (see table ECO).

Code	Description	Cover for
29851-*	ECO.R1-*	EPR.110
29852-*	ECO.R2-*	EPR.120

* Complete with colour index (C1, ..., C17).

STANDARD EXECUTIONS

Pass-through holes for AISI 304 stainless steel self-tapping screws according to ISO 7050 Ø 2.9x9.5 mm, supplied (see Assembly instructions).

- **EPR-SH**: open cavity handle without flap.
- **EPR-F-SH**: handle with grey-black technopolymer flap, matte finish, stainless steel return spring.

ERGONOMY AND DESIGN

A modern design thanks to the compact shape. The internal profile of the cavity offers a safe, comfortable and ergonomic grip. The coloured screw cover improves the visibility of the handle and offers the possibility of product customisation.

The flap is a unique feature for closing completely the recess and opens by simply putting the hand into.

TECHNICAL DATA

The lifting (F1) and pull out (F2) resistance values reported in the table are the result of the tests carried out in laboratory with handles assembled on strengthened metal sheet panels with thickness = 1.5 mm (strengthened for test purposes).

DRILLING TEMPLATE

On panels with thickness (s) exceeding 2.5 mm, we recommend you to fit the handle following one of the here-under reported ways:

- by two self-tapping screws in the bores "d";
- by two countersunk head screws M3x6 after tapping the bores in the panel;
- by two countersunk head screws M3x10 with nuts, after drilling blind holes Ø 3.2 mm.



ERGOSTYLE® ELESA Original design 2007

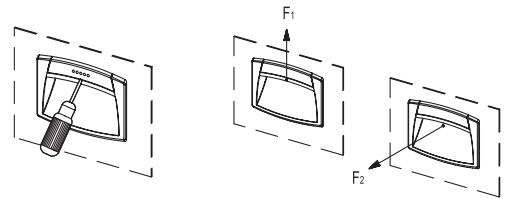

Drilling template
(remove all drilling burrs before fitting the handle)

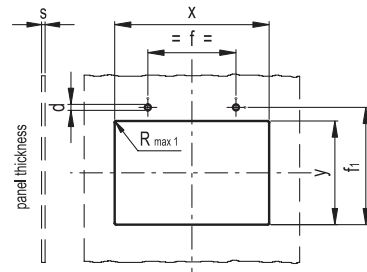

s	EPR.110					EPR.120				
	x	y	f	f1	x	y	f	f1	d	
1+1.2	100 ^{+0.2}	52 ^{+0.5}	64 ^{±0.1}	55.5 ^{±0.1}	107.5 ^{+0.2}	73 ^{+0.5}	64 ^{±0.1}	76.8 ^{±0.1}	2.5 ^{±0.02}	
>1.2+1.5	100 ^{+0.2}	52.2 ^{+0.5}	64 ^{±0.1}	55.7 ^{±0.1}	107.5 ^{+0.2}	73 ^{+0.5}	64 ^{±0.1}	77 ^{±0.1}	2.55 ^{±0.02}	
>1.5+2	100 ^{+0.2}	52.5 ^{+0.5}	64 ^{±0.1}	56 ^{±0.1}	107.5 ^{+0.2}	73 ^{+0.5}	64 ^{±0.1}	77.2 ^{±0.1}	2.6 ^{±0.02}	
>2+2.5	100 ^{+0.2}	52.7 ^{+0.5}	64 ^{±0.1}	56.2 ^{±0.1}	107.5 ^{+0.2}	74 ^{+0.5}	64 ^{±0.1}	77.5 ^{±0.1}	2.65 ^{±0.02}	
>2.5+3	100 ^{+0.2}	53 ^{+0.5}	64 ^{±0.1}	56.5 ^{±0.1}	107.5 ^{+0.2}	74 ^{+0.5}	64 ^{±0.1}	77.8 ^{±0.1}	2.65 ^{±0.02}	
>3+3.5	100 ^{+0.2}	53.2 ^{+0.5}	64 ^{±0.1}	56.7 ^{±0.1}	107.5 ^{+0.2}	74 ^{+0.5}	64 ^{±0.1}	78.1 ^{±0.1}	2.7 ^{±0.02}	
>3.5+4	100 ^{+0.2}	53.4 ^{+0.5}	64 ^{±0.1}	56.9 ^{±0.1}	107.5 ^{+0.2}	75 ^{+0.5}	64 ^{±0.1}	78.4 ^{±0.1}	2.7 ^{±0.02}	
>4+4.5	100 ^{+0.2}	53.6 ^{+0.5}	64 ^{±0.1}	57.1 ^{±0.1}	107.5 ^{+0.2}	75 ^{+0.5}	64 ^{±0.1}	78.7 ^{±0.1}	2.7 ^{±0.02}	
>4.5+5	100 ^{+0.2}	53.8 ^{+0.5}	64 ^{±0.1}	57.3 ^{±0.1}	107.5 ^{+0.2}	75 ^{+0.5}	64 ^{±0.1}	79 ^{±0.1}	2.7 ^{±0.02}	

ASSEMBLY INSTRUCTIONS

1. Drill the handle housing according to the template dimensions.
2. Remove all drilling burrs before fitting the handle.
3. Fit the upper part of the handle into the housing (Fig. 1) and press onto the lower part until firmly in place.
4. Gently push the handle downward (Fig. 2).
5. Fit the two self-tapping screws (Fig. 3).
6. Assemble the screw cover by pressing on the lateral sides first and finally on the central part (Fig. 4).

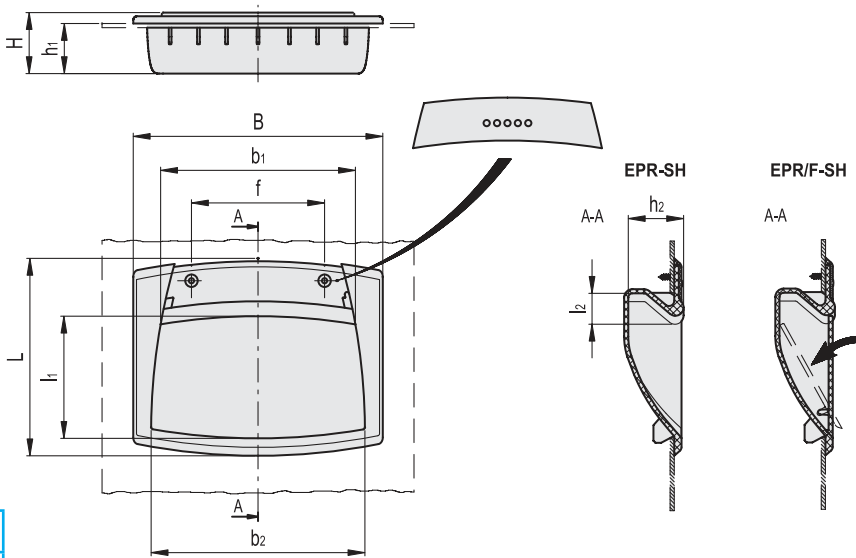
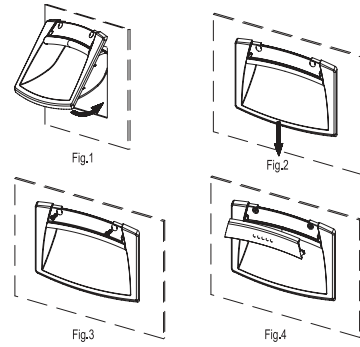

Conversion Table	
1 mm = 0.039 inch	
B	
mm	inch
109	4.29
120	4.72



*Complete with colour index, example: 261091-C2 EPR.110-SH-C2

- C1 RAL7021
- C2 RAL2004
- C3 RAL7035
- C4 RAL1021
- C5 RAL5024
- C6 RAL3000
- C17 RAL6017

METRIC

Code	Description	B	f	L	H	h1	h2	b1	b2	l1	l2	F1 [N]	F2 [N]	⚖️
261091-*	EPR.110-SH-*	109	64	73	24	20	21.5	90	96	42	9	1300	500	39
261121-*	EPR.120-SH-*	120	64	95	28.5	24	26.5	94	103	58	11	1200	400	55
261131-*	EPR.120/F-SH-*	120	64	95	28.5	24	26.5	94	103	-	11	1200	400	70

