

N° 140778  
A3

METRIC		CODE	GAGE NO

NOTES -  $\Delta$  NI PLATED 112-25.2 THK .000150 MIN. OVER COPPER FLASH  
LUBRICATE AFTER PLATING SPEC 118-53.2  
COPPER FLASH OPTIONAL FOR FOREIGN PRODUCTION  
2 SPLICE FREE PER SPEC 115-1000

$\Delta$  TIN PLATED 112-16.3 THK .000080/.000250  
 $\Delta$  FOREIGN PRODUCTION  
 $\Delta$  FOR SPANISH PRODUCTION = Nickel plated per 112-246-1  
.000110 (3  $\mu$ m) min thk. over optional copper flash.  
Lubricate after plating (4-790452-3).

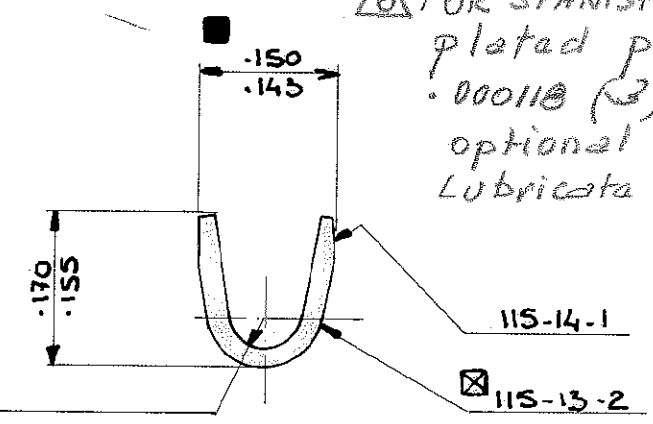
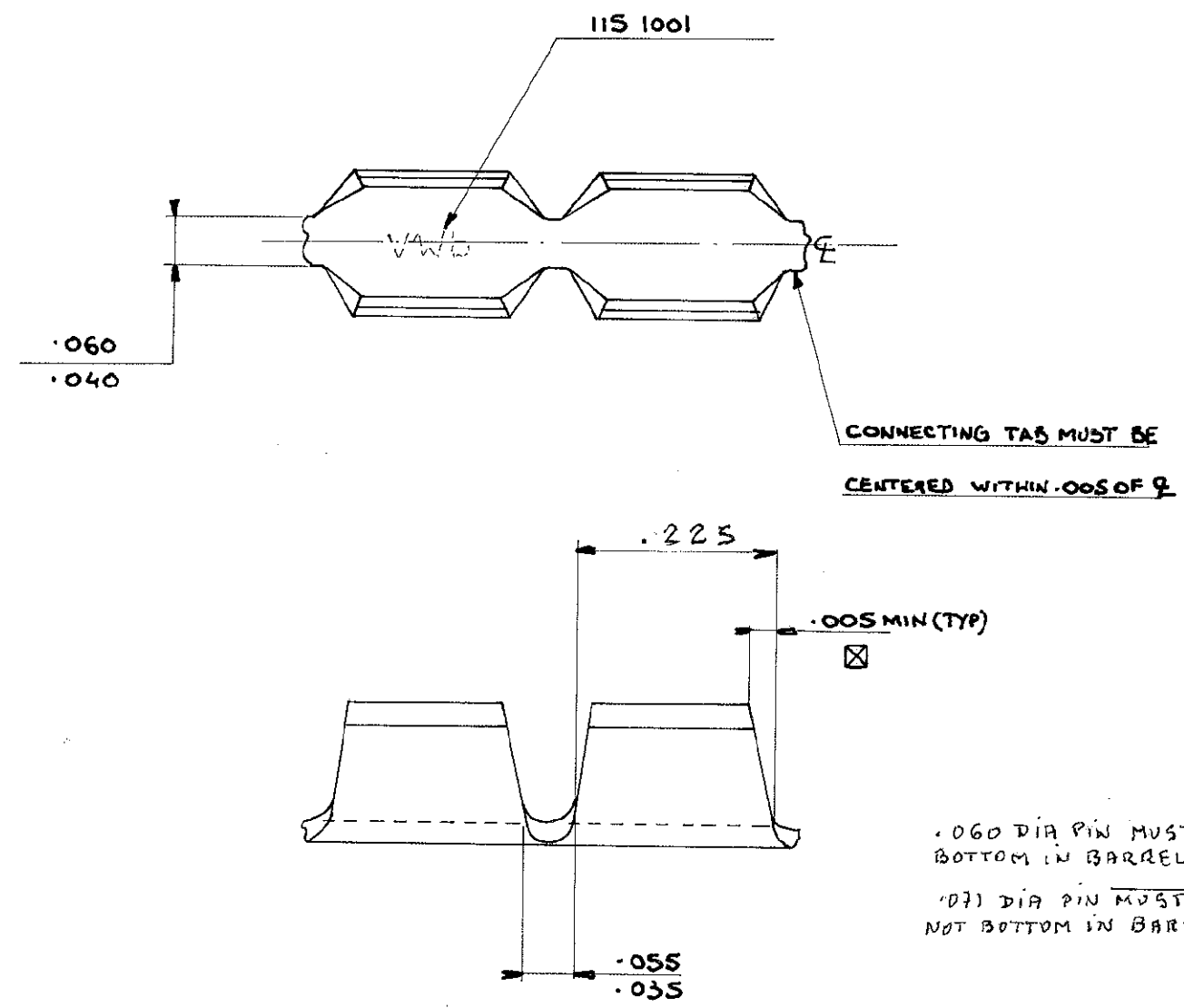

$\Delta$	PRE-NI PLATED 112-25.2 THK 2.0 MIN	STEEL 100-21 T4	140837-3
$\Delta$	NICKEL PLATED 112-25.2	STEEL 100-21 T4	140837-2
	PLAIN		140837-1
	TIN PLATED 112-16.3	BRASS 100-41027 T2	140778-2
	PLAIN		140778-1
	MATERIAL STOCK NUMBER	FINISH	AMP PART NUMBER

Ce plan est confidentiel, il ne peut être communiqué à quiconque n'appartient pas à AMP sans une autorisation écrite de AMP de France SA

DIMENSIONS IN MM. DO NOT SCALE PRINT. Dimensions en mm. Restitution non à l'échelle

K	Added NOTE 6	8/29	DR 11/01
J	285 WAS 209/219	10M WAS 2014	DR 11/31/87
I	WITHDRAWN NOTE B	4618	REV 11/1/87
H	ADDED PN 140837-3	4602	REV 2/2/87
G	REDRAWN AND UP DATED	4474	REV 11/16/87
	WAS NPS		
DIST	1		
LTR	REVISION RECORD	ECN	DR DATE

SPECIFICATIONS	WIRE CRIMP	INS. CRIMP	SB.
REELING - 107-3 FIG 10	LAYOUT NO	SURFACE AREA - 1842 SQ. IN	QTY/REEL
SPLICE - 115	DIE 1253		10M
HEAT TREATING - 111	DIE FEED	APPL FEED	
FINISH - 112			
	WDW .343	IDW	

STOCK THK .0201 x .343	REF	REF	WIRE RANGE
TRIMMING BURR NOT TO EXCEED	IN.	IN.	1.500 TO 4.500 CMA
Control Priority Dimensions		UNLESS OTHER WISE SPECIFIED ± 0.12 MM	
<input checked="" type="checkbox"/> CRITICAL	<input checked="" type="checkbox"/> MAJOR	NAME	
<input type="checkbox"/> None	<input type="checkbox"/> MINOR	SPLICE	
DR B. ALLAIS 12 JANVIER 1987	APPD	SCALE	LOC
CHK REL 11/2/87	REL	5	F B

NUMBER	SHEET	REV
140778	1/1	K