

## Description

The AP4370 is a decoding IC compatible to Qualcomm High Voltage Dedicated Charging Port (HVDCP) Quick Charge (QC) 2.0 protocol. It decodes the different combinations of D+/D- signals, generated by the portable device, into the related configurations of V1/V2, which can be used to change either voltage reference or voltage feedback divider resistor for the controller IC to make the further constant voltage/constant current control. The AP4370 has over voltage discharge feature to accelerate output voltage decline transition. The AP4370 automatically provides 5V output configuration for the connected portable device that is not compatible to Qualcomm QC 2.0 protocol.

The AP4370 is packaged in SOT26 package.

## Features

- Compatible to Qualcomm HVDCP Quick Charge 2.0 Protocol Class A: 5V/9V/12V
- Ultra Low Static Current: 80µA at 5V V<sub>CC</sub>
- Wide V<sub>CC</sub> Supply Voltage: 4.5V to 15V
- Over Voltage Discharge Feature to Accelerate Output Voltage Decline Transition
- Small Profile: SOT26 SMD Package in Accordance with Level 3 of IPC/JEDEC J-STD-033A
- **Totally Lead-free & Fully RoHS Compliant (Notes 1 & 2)**
- **Halogen and Antimony Free. "Green" Device (Note 3)**

- Notes:
1. No purposely added lead. Fully EU Directive 2002/95/EC (RoHS) & 2011/65/EU (RoHS 2) compliant.
  2. See [http://www.diodes.com/quality/lead\\_free.html](http://www.diodes.com/quality/lead_free.html) for more information about Diodes Incorporated's definitions of Halogen- and Antimony-free, "Green" and Lead-free.
  3. Halogen- and Antimony-free "Green" products are defined as those which contain <900ppm bromine, <900ppm chlorine (<1500ppm total Br + Cl) and <1000ppm antimony compounds.

## Pin Assignments

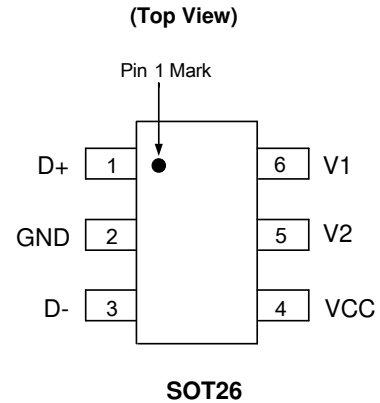

## Applications

- Chargers/ Adapters

## Typical Applications Circuit

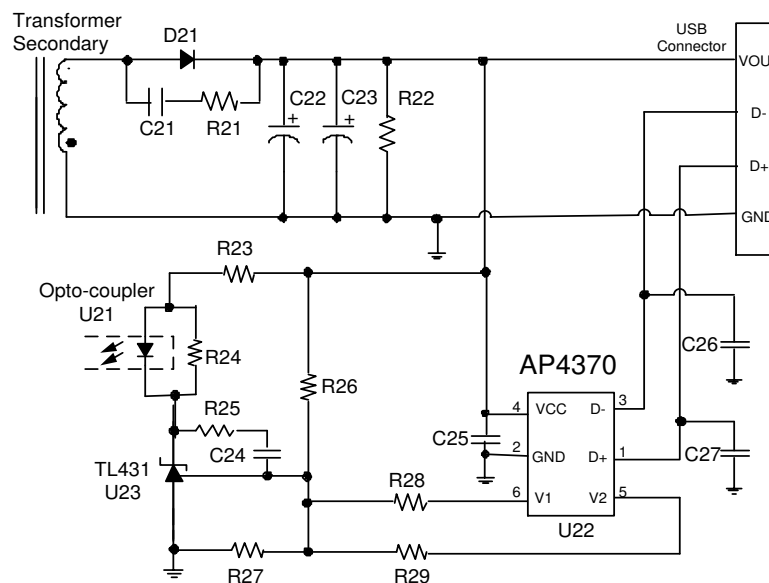

## Pin Descriptions

| Pin Number | Pin Name | Function   |
|------------|----------|--|
| 1          | D+       | USB D+ Input   |
| 2          | GND      | Ground Return  |
| 3          | D-       | USB D- Input   |
| 4          | VCC      | IC Supply Voltage, connected to a ceramic cap.                                 |
| 5          | V2       | Decoder Output2, used as input of constant voltage/constant current controller |
| 6          | V1       | Decoder Output1, used as input of constant voltage/constant current controller |

## Functional Block Diagram

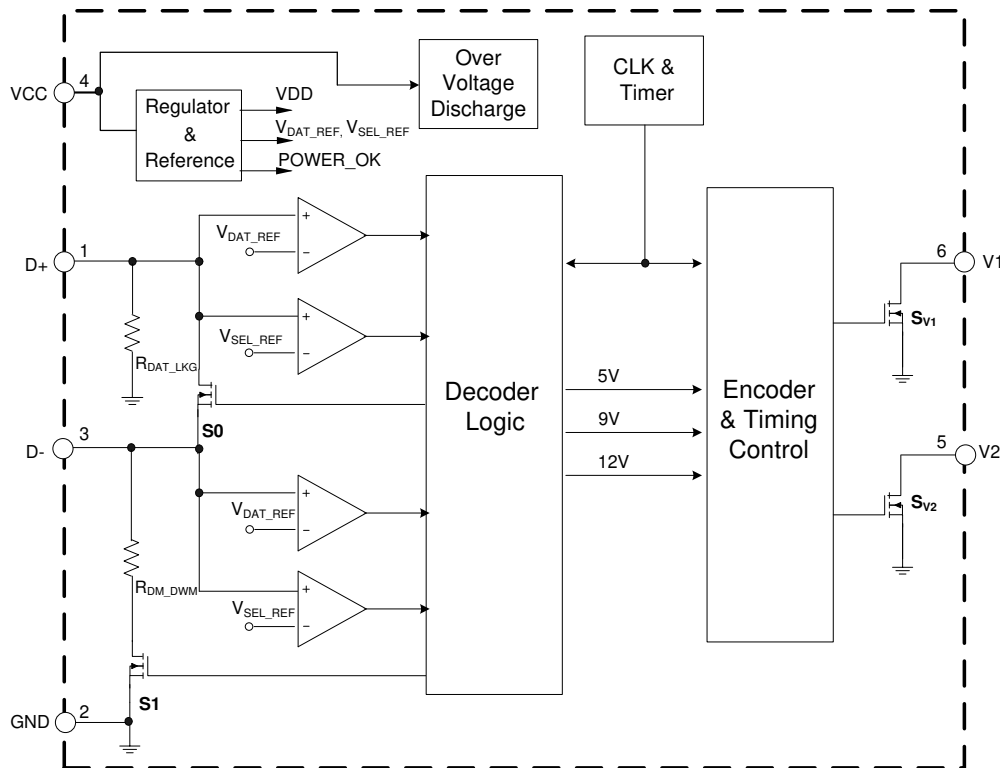

## Absolute Maximum Ratings (Note 4)

| Symbol                           | Parameter                                | Rating      | Unit |
|----------------------------------|--|-------------|------|
| V <sub>CC</sub>                  | IC Supply Voltage                        | -0.3 to 25  | V    |
| V <sub>D+</sub> /V <sub>D-</sub> | USB Input Voltage                        | -0.3 to 7   | V    |
| V <sub>V1</sub> /V <sub>V2</sub> | Decoder Output Voltage                   | -0.3 to 7   | V    |
| T <sub>J</sub>                   | Operating Junction Temperature           | -40 to +150 | °C   |
| T <sub>STG</sub>                 | Storage Temperature                      | -65 to +150 | °C   |
| T <sub>LEAD</sub>                | Lead Temperature (Soldering, 10 sec)     | +300        | °C   |
| θ <sub>JA</sub>                  | Thermal Resistance (Junction to Ambient) | 200         | °C/W |
| ESD                              | ESD (Human Body Model)                   | 4000        | V    |
|                                  | ESD (Machine Model)                      | 150         | V    |

Note 4: Stresses greater than those listed under "Absolute Maximum Ratings" may cause permanent damage to the device. These are stress ratings only, and functional operation of the device at these or any other conditions beyond those indicated under "Recommended Operating Conditions" is not implied. Exposure to "Absolute Maximum Ratings" for extended periods may affect device reliability.

**Electrical Characteristics** ( $V_{CC} = 5V$ ,  $T_A = +25^{\circ}C$ , unless otherwise specified.)

| Symbol                                | Parameters  | Conditions               | Min    | Typ   | Max   | Unit |
|---------------------------------------|---|--------------------------|--------|-------|-------|------|
| <b>STARTUP AND UVLO SECTION</b>       |   |                          |        |       |       |      |
| $V_{TH\_ST}$                          | V <sub>CC</sub> Startup Threshold                                 | –                        | 3.4    | 3.8   | 4.2   | V    |
| $V_{OPR(MIN)}$                        | V <sub>CC</sub> Minimal Operating Voltage                         | –                        | 3.2    | 3.6   | 4.0   | V    |
| <b>STANDBY CURRENT SECTION</b>        |   |                          |        |       |       |      |
| $I_{CC}$                              | Operating Current   | –                        | –      | 80    | 120   | μA   |
| <b>QUICK CHARGE PROTOCOL SECTION</b>  |   |                          |        |       |       |      |
| $V_{DAT\_REF}$                        | Data Detect Voltage   | –                        | 0.25   | 0.325 | 0.40  | V    |
| $V_{SEL\_REF}$                        | Output Voltage Selection Reference                                | –                        | 1.8    | 2.0   | 2.2   | V    |
| $R_{DAT\_LKG}$                        | Data Line Leakage Resistance                                      | –                        | 300    | 500   | 800   | kΩ   |
| $R_{DCP\_DAT}$                        | D+ to D- Resistance during DCP Mode                               | D+ is supplied with 0.6V | –      | 20    | 40    | Ω    |
| $R_{DM\_DWM}$                         | D- Pull-down Resistance   | –                        | 14.25  | 19.53 | 24.80 | kΩ   |
| $t_{GLITCH\_BC\_DONE}$                | D+ High Glitch Filter Time  | –                        | 1      | 1.25  | 1.5   | s    |
| $t_{GLITCH\_DM\_LOW}$                 | D- Low Glitch Filter Time   | Note 5                   | 1      | 2.5   | –     | ms   |
| $t_{GLITCH\_V\_CHANGE}$               | Output Voltage Glitch Filter Time                                 | –                        | 20     | 40    | 60    | ms   |
| $t_{D+\_D-\_SHORT}$                   | D+ D- HVDCP Short Time  | –                        | –      | 10    | 20    | ms   |
| $C_{DCP\_PWR}$                        | D+/- Equivalent Capacitance                                       | Note 5                   | –      | –     | 1     | nF   |
| $V_{OTG\_SESS\_VLD}$                  | OTG Session Valid Voltage   | –                        | 0.8    | –     | 4.0   | V    |
| <b>OUTPUT SECTION</b>                 |   |                          |        |       |       |      |
| $R_{V1\_ON}$                          | V1 Switch Turn-on Resistance                                      | –                        | –      | 15    | 25    | Ω    |
| $R_{V2\_ON}$                          | V2 Switch Turn-on Resistance                                      | –                        | –      | 10    | 18    | Ω    |
| $R_{V1/V2\_OFF}$                      | V1/V2 Switch Turn-off Resistance                                  | –                        | High-Z |       |       | –    |
| <b>OVER VOLTAGE DISCHARGE SECTION</b> |   |                          |        |       |       |      |
| $V_{OVD5V}$                           | Over Voltage Discharge Trigger Point for 5V Output                | –                        | 5.96   | 6.15  | 6.33  | V    |
| $V_{OVD9V}$                           | Over Voltage Discharge Trigger Point for 9V Output                | –                        | 10.58  | 10.91 | 11.24 | V    |
| $k_{DIS}$                             | Ratio of Target Voltage for Discharge Finish to OVD Trigger Point | –                        | –      | 0.9   | –     | –    |
| $I_{OVD}$                             | Over Voltage Discharge Current                                    | –                        | 65     | 85    | 110   | mA   |
| $t_{OVD}$                             | Over Voltage Discharge Duration                                   | –                        | –      | 120   | –     | ms   |

Note 5: Guaranteed by design.

## Operation Principle Description

### Overall Introduction

The figure on page 1 is the typical application circuit of AP4370, which follows Qualcomm HVDC Quick Charge 2.0 Protocol to decode the different combinations of D+/D- signals, generated by the portable device, into the related configurations of V1/V2 for the controller IC to make the further constant voltage/constant current control. The AP4370 automatically provides 5V output configuration for the connected portable device that is not compatible to QC 2.0 protocol. When the portable device requests a lower output voltage, the AP4370 will have over voltage discharge function operate until the output voltage reaches  $V_{OVDxV} * K_{DIS}$  or the time duration is over  $t_{OVD}$ .

### Quick Charge 2.0 Protocol Operation

The switches of S1, S<sub>V1</sub> and S<sub>V2</sub> (shown in Functional Block Diagram on page 2) will be kept turn-off during the start-up phase, and the default V1/V2 configuration ensures that the charger/adaptor is regulated into 5V output voltage. S0 switch will be turned on to short D+ to D- at start-up voltage within  $V_{OTG\_SESS\_VLD}$  (0.8V to 4.0V). If AP4370 finds D+ voltage is between  $V_{DAT\_REF}$  (0.325V, typical) and  $V_{SEL\_REF}$  (2.0V, typical) lasting for  $t_{GLITCH\_BC\_DONE}$ , it will turn off S0 to have D+ / D- open, and turn on S1 to have D- connected to GND via  $R_{DM\_DWM}$  (19.53kΩ, typical). AP4370 will ensure that D- stays low voltage for more than  $t_{GLITCH\_DM\_LOW}$  (1ms, min) to successfully complete Qualcomm QC 2.0 protocol handshake. After that, AP4370 can respond to the voltage request made by the portable device via D+/D- data lines. If AP4370 detects that D+/D- keeps voltage unchanged for a glitch filter period of  $t_{GLITCH\_V\_CHANGE}$  (40ms, typical), it will follow the voltage decoding table below to configure V1/V2 by turning on/off S<sub>V1</sub> and S<sub>V2</sub> to output the target voltage. Finally, after the portable device is removed from USB connector, AP4370 will have D+ shorted to D- within  $t_{D+_D-\_SHORT}$  (20ms, max), configure V1/V2 to 5V output, and is ready for next handshake.

| Decoder  | D+ (V)     | D- (V)            | V1 Switch(S <sub>V1</sub> ) Status  | V2 Switch(S <sub>V2</sub> ) Status | HVDCP Voltage (V)                  |
|--|------------|-------------------|-------------------------------------|------------------------------------|------------------------------------|
| Quick Charge 2.0 Protocol Class A: 5V, 9V, 12V | 0.6        | 0.6               | Turn-on                             | Turn-on                            | 12                                 |
|  | 3.3        | 0.6               | Turn-on                             | Turn-off                           | 9                                  |
|  | 0.6        | 3.3               | Keep Present V1/V2 Status Unchanged |                                    |                                    |
|  | 3.3        | 3.3               | Keep Present V1/V2 Status Unchanged |                                    |                                    |
|  | 0.6 or 3.3 | GND               | Turn-off                            | Turn-off                           | 5                                  |
|  | GND        | 0.6 or 3.3 or GND | Turn-off                            | Turn-off                           | 5, AP4370 Protocol Handshake Reset |

Table 1. D+/D- Voltage Decoder

**Performance Characteristics**

**Startup Voltage vs. Ambient Temperature**

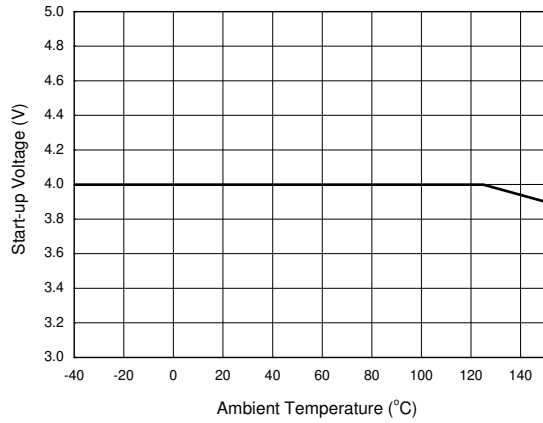

**Minimal Operating Voltage vs. Ambient Temperature**

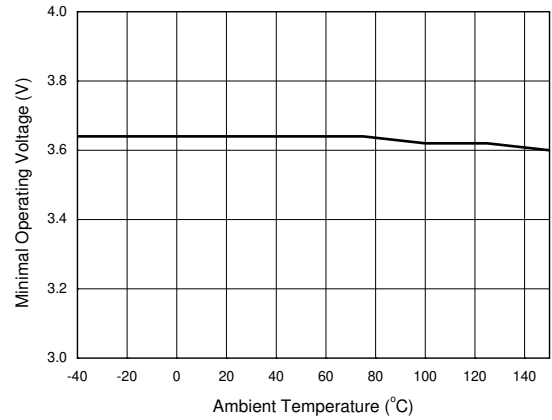

**Operating Current vs. Ambient Temperature**

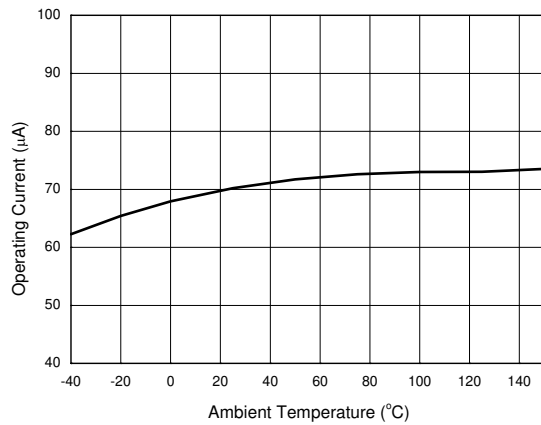

**Data Line Leakage Resistance vs. Ambient Temperature**

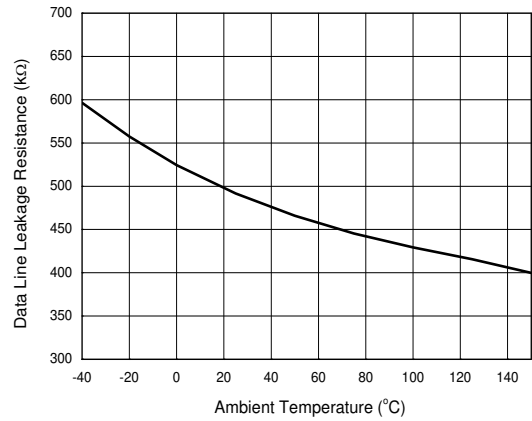

**D+ to D- Resistance During DCP Mode vs. Ambient Temperature**

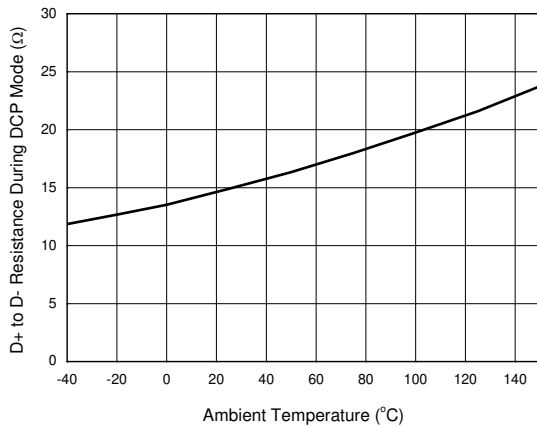

**D- Pull-down Resistance vs. Ambient Temperature**

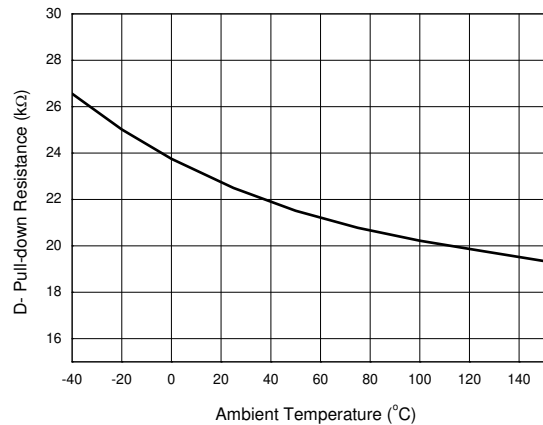

**Performance Characteristics (Cont.)**

NEW PRODUCT

**Data Detect Voltage vs. Ambient Temperature**

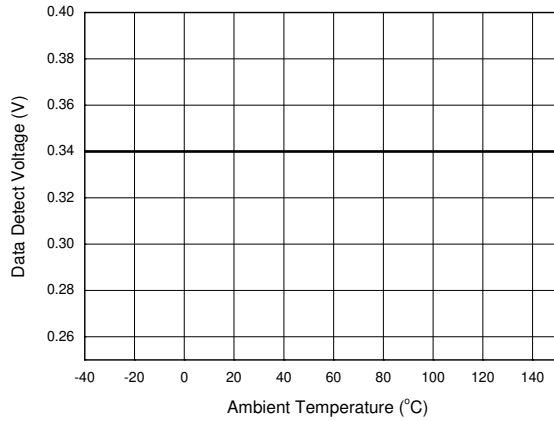

**Output Voltage Selection Reference vs. Ambient Temperature**

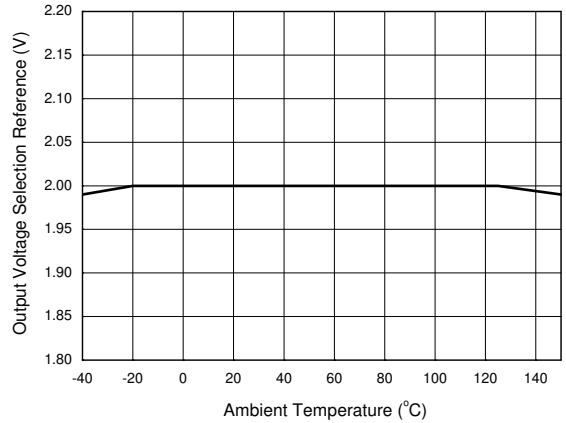

**D+ High Glitch Filter Time vs. Ambient Temperature**

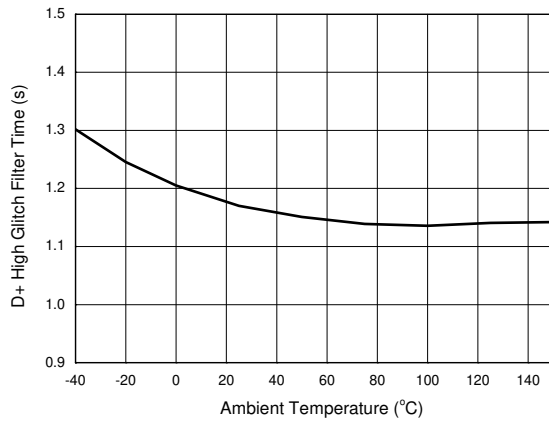

**Output Voltage Glitch Filter Time vs. Ambient Temperature**

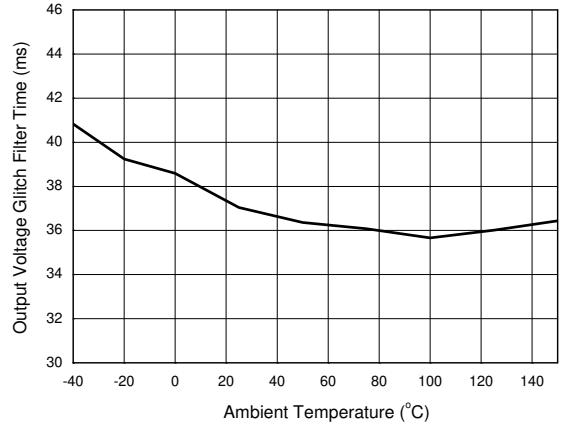

**V1 Switch Turn-on Resistance vs. Ambient Temperature**

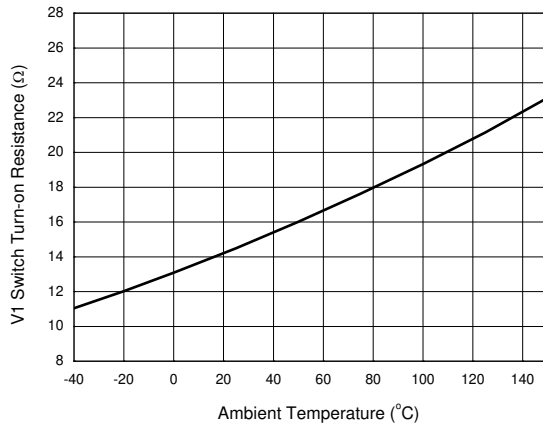

**V2 Switch Turn-on Resistance vs. Ambient Temperature**

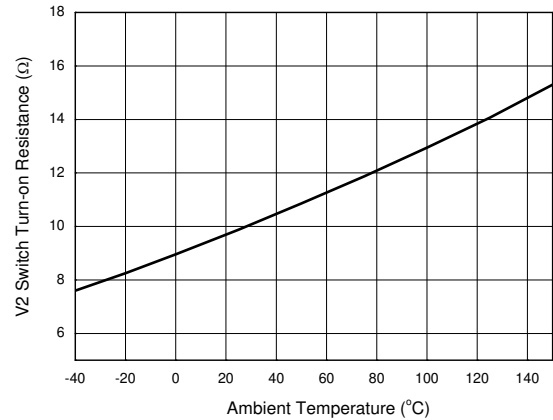

**Ordering Information**

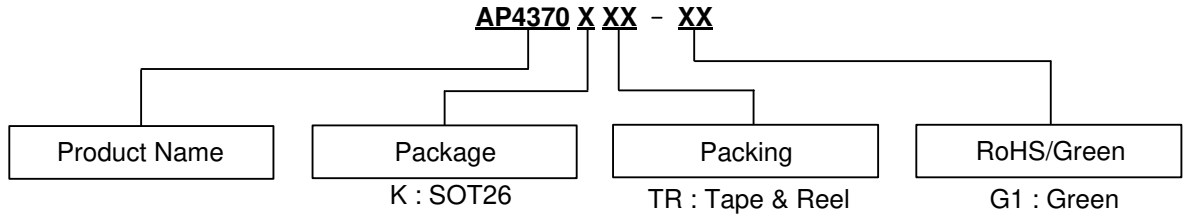

| Package | Temperature Range | Part Number  | Marking ID | Packing          |
|---------|-------------------|--------------|------------|------------------|
| SOT26   | -40 to +85°C      | AP4370KTR-G1 | L9H        | 3000/Tape & Reel |

**Marking Information**

(Top View)

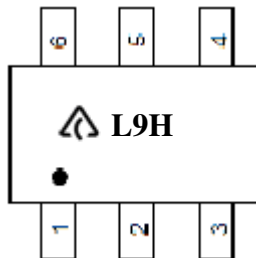

: Logo  
 L9H: Marking ID

**Package Outline Dimensions** (All dimensions in mm(inch).)

(1) Package Type: SOT26

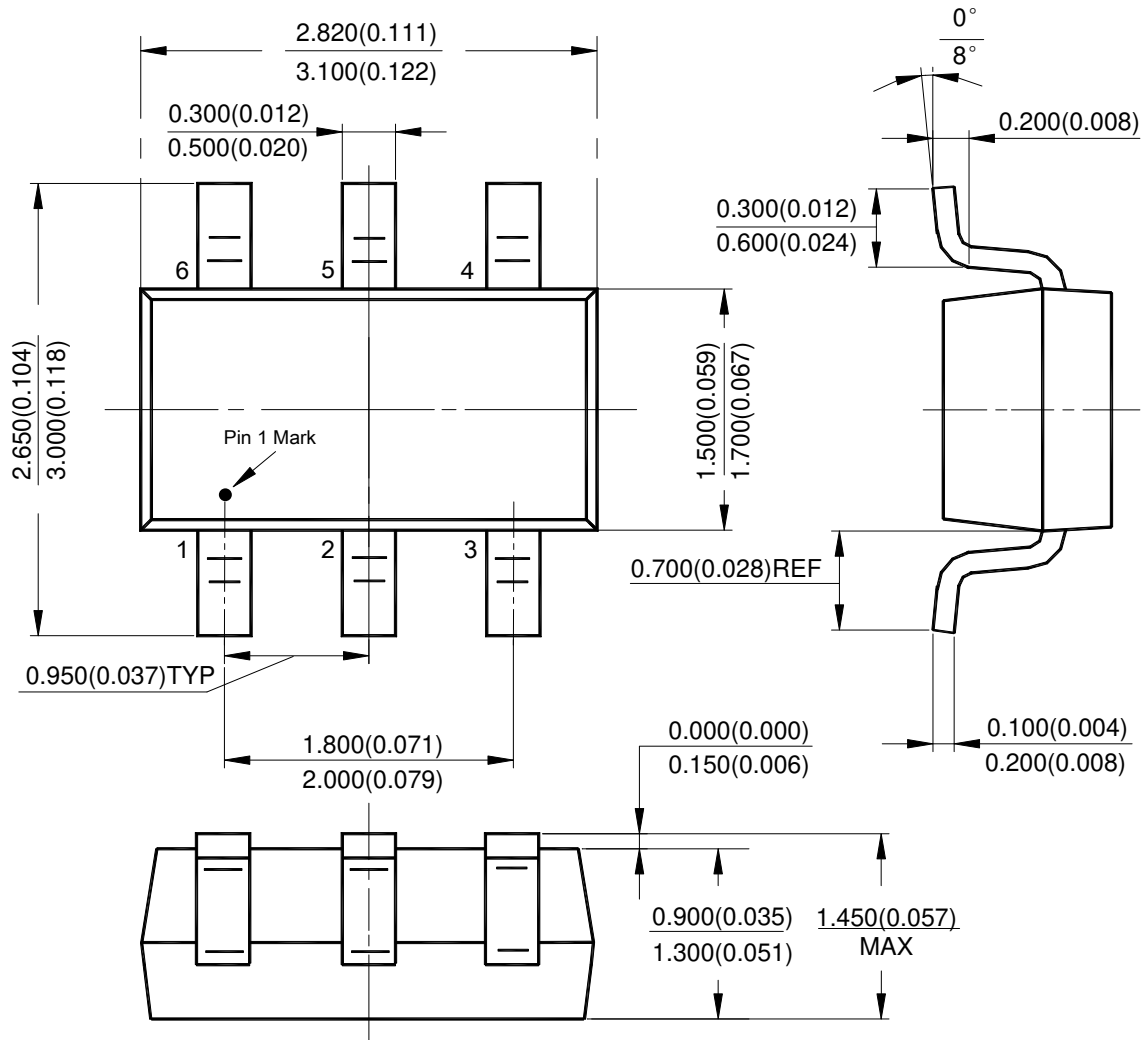

NEW PRODUCT



**Suggested Pad Layout**

(1) Package Type: SOT26

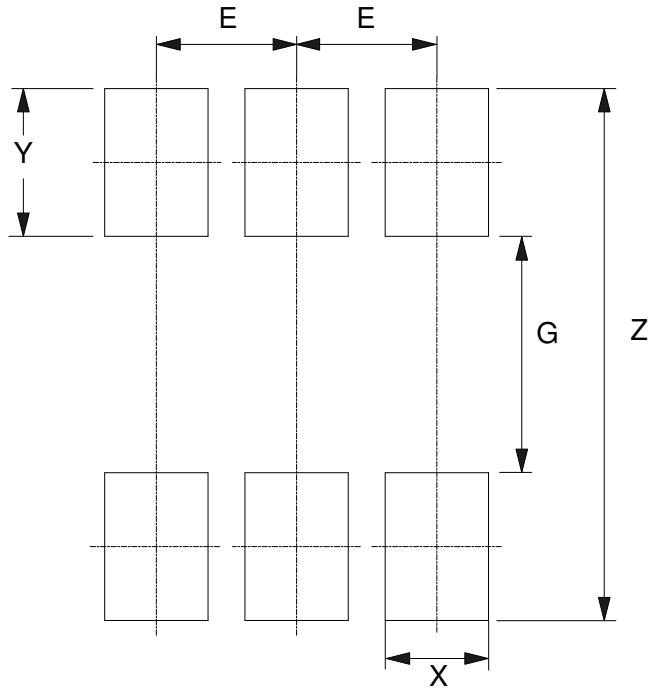

| Dimensions | Z<br>(mm)/(inch) | G<br>(mm)/(inch) | X<br>(mm)/(inch) | Y<br>(mm)/(inch) | E<br>(mm)/(inch) |
|------------|------------------|------------------|------------------|------------------|------------------|
| Value      | 3.600/0.142      | 1.600/0.063      | 0.700/0.028      | 1.000/0.039      | 0.950/0.037      |

NEW PRODUCT

**IMPORTANT NOTICE**

DIODES INCORPORATED MAKES NO WARRANTY OF ANY KIND, EXPRESS OR IMPLIED, WITH REGARDS TO THIS DOCUMENT, INCLUDING, BUT NOT LIMITED TO, THE IMPLIED WARRANTIES OF MERCHANTABILITY AND FITNESS FOR A PARTICULAR PURPOSE (AND THEIR EQUIVALENTS UNDER THE LAWS OF ANY JURISDICTION).

Diodes Incorporated and its subsidiaries reserve the right to make modifications, enhancements, improvements, corrections or other changes without further notice to this document and any product described herein. Diodes Incorporated does not assume any liability arising out of the application or use of this document or any product described herein; neither does Diodes Incorporated convey any license under its patent or trademark rights, nor the rights of others. Any Customer or user of this document or products described herein in such applications shall assume all risks of such use and will agree to hold Diodes Incorporated and all the companies whose products are represented on Diodes Incorporated website, harmless against all damages.

Diodes Incorporated does not warrant or accept any liability whatsoever in respect of any products purchased through unauthorized sales channel. Should Customers purchase or use Diodes Incorporated products for any unintended or unauthorized application, Customers shall indemnify and hold Diodes Incorporated and its representatives harmless against all claims, damages, expenses, and attorney fees arising out of, directly or indirectly, any claim of personal injury or death associated with such unintended or unauthorized application.

Products described herein may be covered by one or more United States, international or foreign patents pending. Product names and markings noted herein may also be covered by one or more United States, international or foreign trademarks.

This document is written in English but may be translated into multiple languages for reference. Only the English version of this document is the final and determinative format released by Diodes Incorporated.

**LIFE SUPPORT**

Diodes Incorporated products are specifically not authorized for use as critical components in life support devices or systems without the express written approval of the Chief Executive Officer of Diodes Incorporated. As used herein:

A. Life support devices or systems are devices or systems which:

1. are intended to implant into the body, or
2. support or sustain life and whose failure to perform when properly used in accordance with instructions for use provided in the labeling can be reasonably expected to result in significant injury to the user.

B. A critical component is any component in a life support device or system whose failure to perform can be reasonably expected to cause the failure of the life support device or to affect its safety or effectiveness.

Customers represent that they have all necessary expertise in the safety and regulatory ramifications of their life support devices or systems, and acknowledge and agree that they are solely responsible for all legal, regulatory and safety-related requirements concerning their products and any use of Diodes Incorporated products in such safety-critical, life support devices or systems, notwithstanding any devices- or systems-related information or support that may be provided by Diodes Incorporated. Further, Customers must fully indemnify Diodes Incorporated and its representatives against any damages arising out of the use of Diodes Incorporated products in such safety-critical, life support devices or systems.

Copyright © 2016, Diodes Incorporated

[www.diodes.com](http://www.diodes.com)