

REV.	DESCRIPTION	DATE	APPROVED
B	Engineering Update w/o Changes	02/27/04	M. C.
C	Removed Material Code & P/N Correction	05/28/16	J. C.

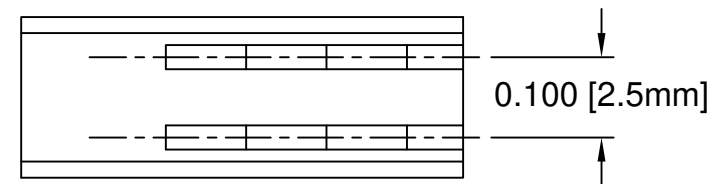
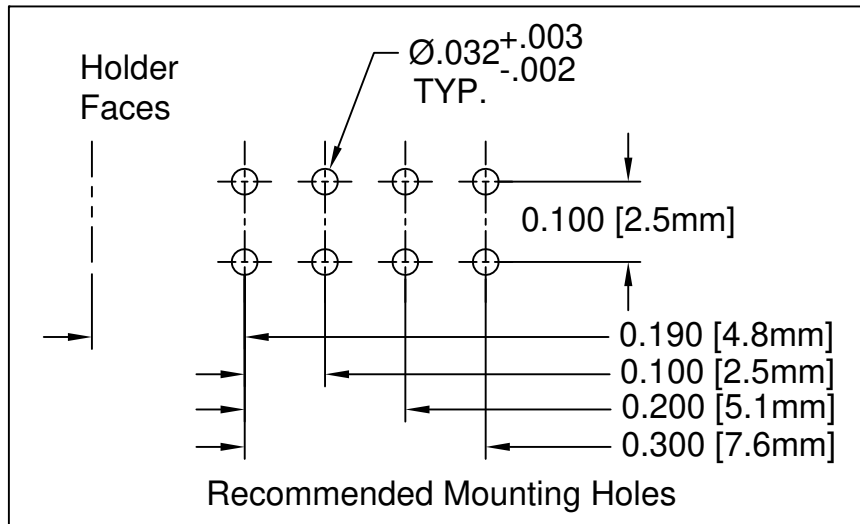
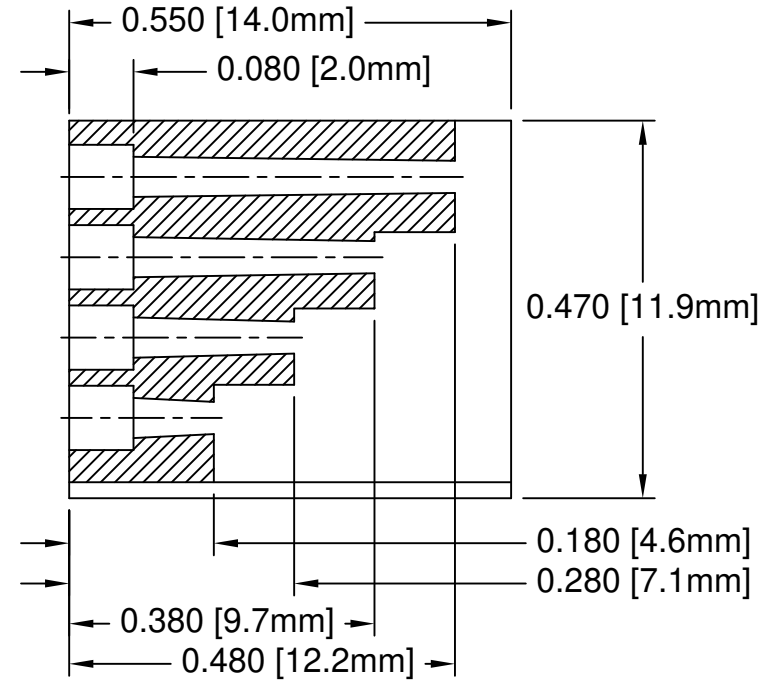
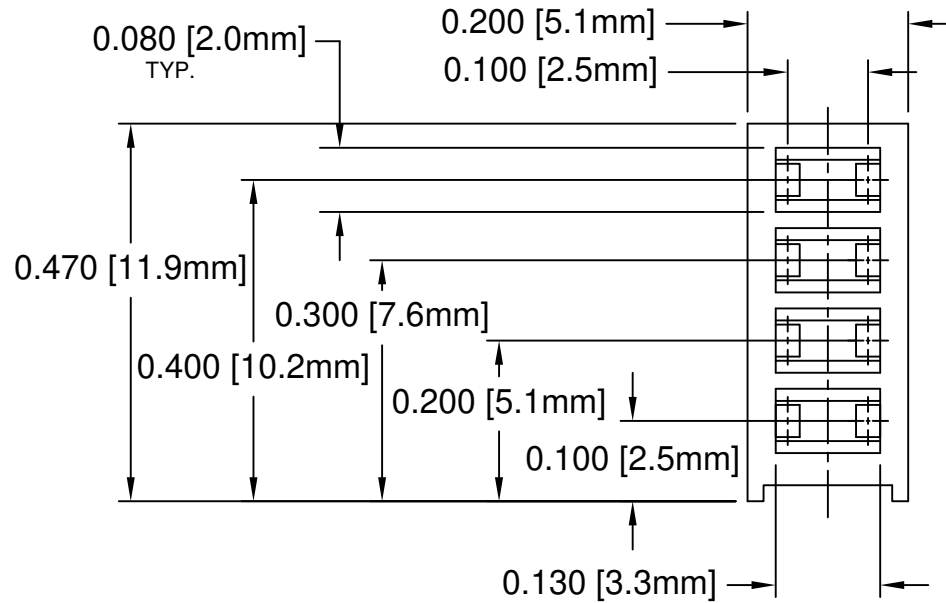

2. MATERIAL: NYLON 6/6, 94V-0, BLACK.

1. GENERAL SPECIFICATIONS: BIVAR MOLDED COMPONENT SPECIFICATION BV00-E101.

STANDARD TOLERANCE (UNLESS OTHERWISE SPECIFIED)		BIVAR®	
DECIMALS	ANGULAR	4 THOMAS, IRVINE, CA. 92618	
.X ± .1	X° ± 1°	TEL: (949) 951-8808 FAX: (949) 951-3974	
.XX ± .01		<b>TITLE:</b> QUAD-LEVEL 2X3mm LED HOLDER	
.XXX ± .005		<b>PART NO:</b> H-480C	
DESIGNED: <b>S. Irving</b>	DATE: <b>05/28/99</b>	REVISION: <b>C</b>	<b>REVISION:</b>
CHECKED: <b>D. Green</b>	DATE: <b>02/27/04</b>	<b>CAGE CODE :</b> 32559	<b>SHEET #</b> 1 OF 1
CAD GENERATED DOCUMENT. DO NOT MEASURE DRAWING.			