

PRODUCT NUMBER
75160-YXX-XXLF

RoHS COMPLIANT & COMPATIBLE, SEE NOTE 8
TOTAL NB OF POSITIONS 02 TO 36
PIN STYLE SEE SHEET 2

PLATING:

- 1 = 0.76µm FULL GOLD/GXT
- 3 = 2µm MIN MATTE TIN FULL PLATED
- 8 = 0.38µm FULL GOLD/GXT
- 1.27µm MIN NICKEL UNDERPLATING

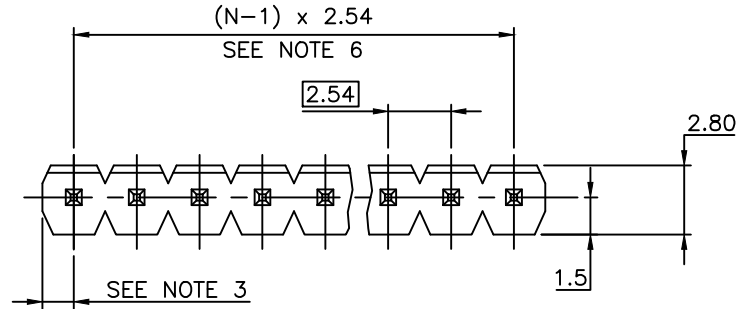

NOTES:

1. HOUSING MAT'L : HIGH TEMPERATURE THERMOPLASTIC FLAME RETARDANT PER UL94-VO, COLOR BLACK.
2. PIN MATERIAL : PHOSPHOR BRONZE.
3. DIM 1.27^{+0.03}/_{-0.13} FOR MOULDED SIDE(S) ONLY. IF SIDE(S) ARE BROKEN, DIM 1.02 TO 1.7 MAX APPLIES.
4. PIN PUSH OUT FORCE : 12N MIN.
5. PRODUCT PACKAGED IN POLY BAGS.
6. TO DETERMINE DIMENSIONS :
N = NUMBER OF POSITIONS
EXAMPLE : 8 POS N x 2.54 = 20.32mm
7. FOR STANDARD SELECTIVE GOLD PLATED PRODUCTS, SEE DRAWING 77311.
8. RoHS COMPATIBLE PRODUCT SPECIFICATIONS
 - a - "LF" MEANS THE PRODUCT IS LEAD-FREE

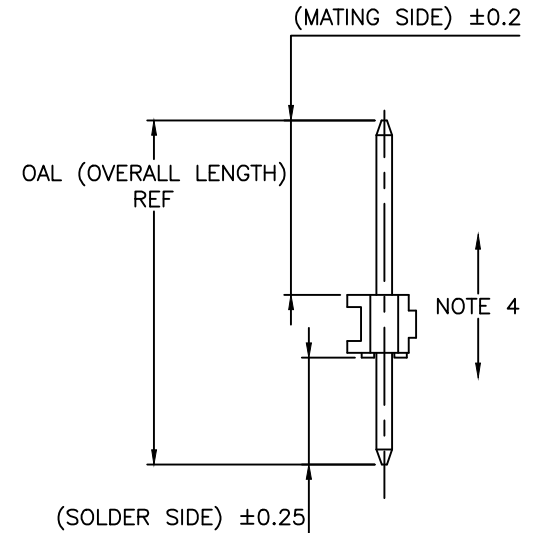
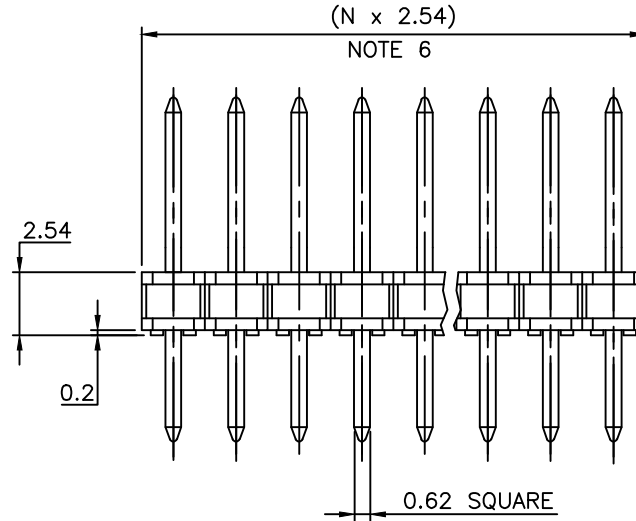

b - MANUFACTURING PROCESS COMPATIBILITY

- THE HOUSING WILL WITHSTAND EXPOSURE TO 260°C ±5°C SOLDER BATH TEMPERATURE FOR 5 SECONDS IN A WAVE SOLDER APPLICATION WITH A 1.6mm MIN THICK CIRCUIT BOARD.

c - LABELING:

- MEETS PACKAGING SPECS AS PER GS-14-920

d - LEGAL STATEMENT: SEE GS-47-0004

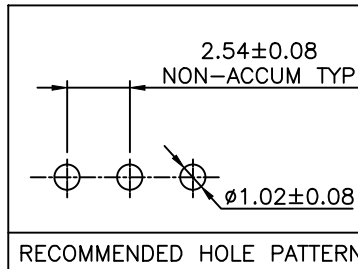

mat'l. code		surface		tolerance		projection		product family	
SEE NOTES		ISO 1302		ISO 406 ISO 1101		mm		BERGSTIK	
lfr	ecn no	dr	date	tolerances unless otherwise specified		mm		title	
BR	F20607	LMU	03.12.03	angles	.x ±0.3	mm		HEADER SR,STR	
BS	F03079	LMU	03.04.04	linear	.xx ±0.15	mm		2.54mm PITCH	
BT	F05-0186	JCO	05.04.29		xxx ±0.05	scale 5:1		dwg no	
BU	F06-0196	LMU	06.06.20	dr	D LEGRAND	02.01.15		sheet 1 of 2 size	
BV	F08-0148	JCO	08.05.27	enrg	JMC	02.01.15		75160 A3	
BW	B-19264	LMU	14.10.31	chr	COMPAGNON	02.01.15		type CUSTOMER Drawing	
				appd	JMC	02.01.15			
sheet index	revision sheet	BW	BK						
		2							

APPLICATION SPECIFIC			
PIN STYLE	MATING	SOLDER	OAL
01	5.72	2.54	10.8
02	5.84	3.43	11.81
03	5.72	5.09	13.34
04	5.72	7.62	15.88
05	5.72	10.16	18.42
06	5.72	12.7	20.96
07	5.72	15.24	23.5
08	5.72	17.78	26.04
09	5.72	20.32	28.58
10	5.72	22.86	31.12
11	5.72	5.97	14.22
12	5.72	8.51	16.76
13	5.72	11.05	19.3
14	5.72	16.13	24.38
15	8.51	2.54	13.59
16	8.51	5.51	16.56
17	8.51	10.59	21.64
18	5.72	3.05	11.3
19	12.83	3.05	18.42
20	15.37	3.05	20.96
21	20.45	3.05	26.04
22	7.75	3.05	13.34
23	5.84	4.95	13.34
24	7.21	3.05	12.8
25	8.51	3.18	14.22
26	15.57	2.84	20.96

APPLICATION SPECIFIC			
PIN STYLE	MATING	SOLDER	OAL
27	6.6	2.67	11.81
28	6.6	4.19	13.34
29	17.53	3.43	23.5
30	22.61	3.43	28.58
31	8.2	2.84	13.59
32	10.29	3.05	15.88
35	25.21	3.37	31.12
38	5.84	3.81	12.19
39	11.17	3.05	16.76
41	4.99	2.8	10.33
43	6.98	4.8	14.32
44	12.27	3.35	18.16
46	8.08	2.72	13.34
48	5.84	2.42	10.8
50	5.84	3.12	11.5
56	5.72	3.05	11.3
61	16.61	3.2	22.35
62	13.5	3.05	19.09
70	6.54	3.5	12.57
73	28.4	3.18	34.12
75	16.47	10.3	29.31
79	3.3	3.3	9.14
80	8.07	2.2	12.81
90	1.9	3.56	8
95	15.96	4	22.5
96	5.84	3.43	11.81

APPLICATION SPECIFIC			
PIN STYLE	MATING	SOLDER	OAL
97	7.75	3.05	13.34
98	10.29	3.05	15.88

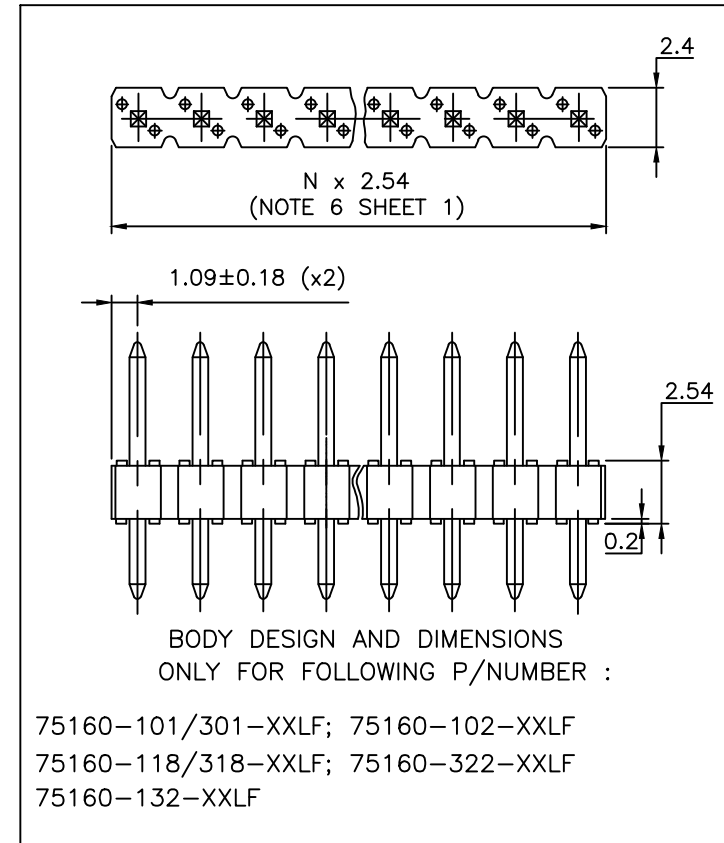

Copyright FCI

mat'l. code	SEE P/N	surface	ISO 1302	tolerance	ISO 406	ISO 1101	projection	product family	BERGSTIK
ltr	ecn no	dr	date	tolerances unless otherwise specified				title	
BH	F05-0186	JCO	05.04.29	angles	.x	±0.3		HEADER STR,SR.	
BJ	F06-0196	LMU	06.06.20	linear	.xx	±0.15	mm	2.54mm PITCH	
BK	B-19264	LMU	14.10.31		xxx	±0.05	scale 5:1	sheet 2 of - size	
	F20301	LMU	02.04.23	dr	MULIN.L	99.04.07		75160 A3	
	F20607	LM	03.12.03	enfr	JMC	99.04.07		type CUSTOMER Drawing	
BF	F20607	LM	03.12.03	chr					
BG	F03079	LMU	03.04.04	appd	JMC	99.04.07			
sheet index	revision sheet								