

Assembly Instructions

1) Slide the ferrule onto the cable. Strip the cable to the dimensions shown. Take care not to nick the centre conductor or braid.

A = 8mm
B = 8mm
C = 3mm

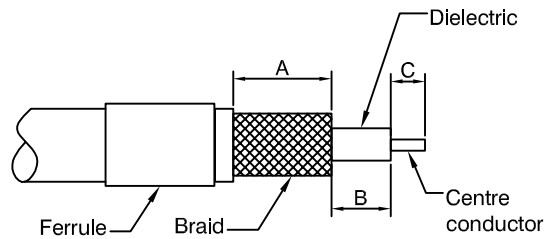

2) Tin the centre conductor of the cable and insert the cable into the body. Ensure that the braid is on the outside of the mandrel and that the center conductor is located in the mounting post.

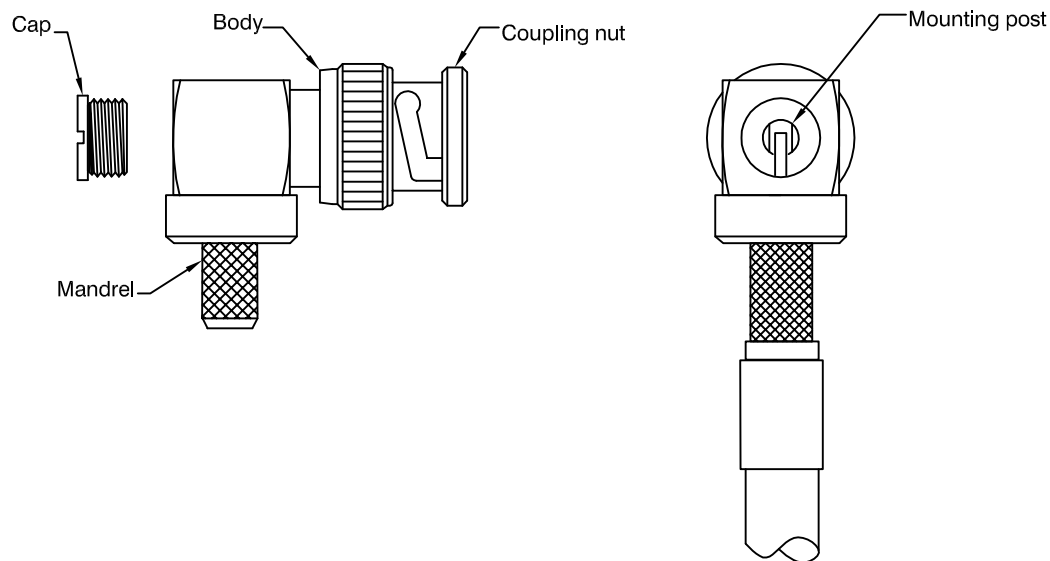

3) Slide the ferrule over the braid until the ferrule butts up against the body. Crimp the ferrule using the correct tool for the connector. Solder the center conductor to the mounting post and fit the end cap in place.

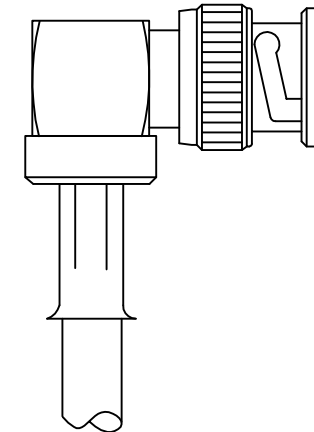

CAD Issue	SN	2	24 July 01
First Issue	CBB	1	17 Nov 99
DESCRIPTION OF REVISION	APPVD	ISS	DATE



Cinch Connectivity Solutions, Ltd
11 Bilton Road
Chelmsford
Essex CM1 2UP, England
T: +44 (0) 1245 342060
F: +44 124 535 8938

SCALE: Not To Scale

DIMENSIONS: mm

TOLERANCES:

DRAWN BY:

S Nash

CHECKED BY:

M Nielsen

APPROVED BY:

P Couzens

DATE:

24 July 01

DESCRIPTION:

Stripping and Assembly
Instructions for BNC Crimp
Right angle Plug

DRAWING NUMBER:

VAIB2101

PAGE: 1 OF 1