

NOTES:

1. MATERIAL:
PHOSPHOR BRONZE, THICKNESS = 0.25mm
2. PLATING:
CONTACT AREA: GOLD PLATING.
CRIMPING AREA:
TIN, THICKNESS=1.875 MICROMETER MINIMUM.
UNDER PLATE:
NICKEL, THICKNESS=1.25 MICROMETER MINIMUM.
3. TO BE USED WITH 67582, 5 SETS TERMINAL PER HOUSING
4. PRODUCT SPECIFICATION REFER TO PS-67490-002
5. PACKAGE SPECIFICATION REFER TO PK-67581-001
6. CRIMPING SPECIFICATION REFER TO CS-47128-001
7. RECOMMEND WIRE SIZE:
18+18/18+20/18+22/20+20/20+22AWG

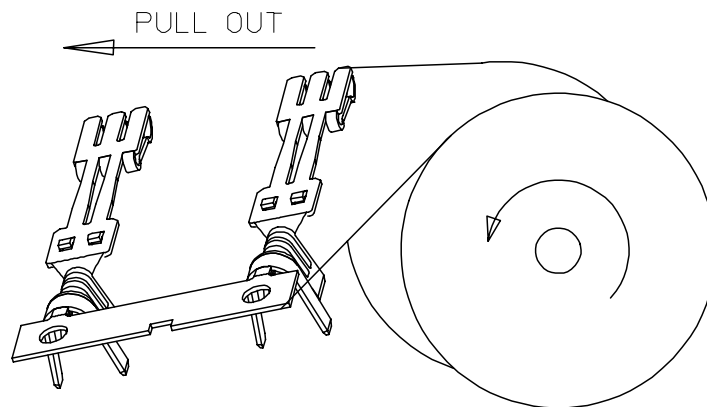

PART NUMBER	PLATING TYPE
47128-1002	0.38 MICRONS GOLD PLATING
47128-1001	0.76 MICRONS GOLD PLATING
47128-1000	GOLD FLASH

EC NO: SH2006-0105	DRWN: GRMA 2005/12/06	CHKD: 2005/12/08	APPR: CCHEN 2006/01/05
D	REV	DESCRIPTION	QUALITY SYMBOLS

QUALITY SYMBOLS	GENERAL TOLERANCES (UNLESS SPECIFIED)	
	mm	INCH
▽ - 1	4 PLACES ± ---	± ---
▽ - 1	3 PLACES ± ---	± ---
▽ - 1	2 PLACES ± 0.25	± ---
▽ - 1	1 PLACE ± 0.3	± ---
▽ - 1	ANGULAR ± 2 °	
▽ - 1	DRAFT WHERE APPLICABLE	
▽ - 1	MUST REMAIN WITHIN DIMENSIONS	

SCALE 4:1	DESIGN UNITS METRIC
DIMENSION STYLE MM ONLY	
DRAWN BY GRATE	DATE 2004/04/05
CHECKED BY YAJUN	DATE 2004/04/05
APPROVED BY SAM	DATE 2004/04/05

THIRD ANGLE PROJECTION	REVISE ON CAD ONLY
TITLE TERMINAL FOR SERIAL ATA POWER CABLE RECEPTACLE CRIMPING TYPE	
MOLEX INCORPORATED	
MATERIAL NO. SEE TABLE	DOCUMENT NO. SD-47128-001
SHEET NO. 1 OF 1	