

DESIGNED & DIMENSIONED
IN MILLIMETERS [INCHES]

TNC-J-C-XX-ST-BH2

DO NOT
SCALE FROM
THIS PRINT

GENDER
-J: JACK

TYPE
-C: CABLE

TERMINATION
-BH2: BULKHEAD FOR CCA-178 CABLE

ORIENTATION
-ST: STRAIGHT

TABLE 1					
ITEM	COMPONENT	-HF	-GF	-HN	-GN
1	SUB ASSEMBLY	SUB-TNC-J-C-F-ST-BH2	SUB-TNC-J-C-F-ST-BH2	SUB-TNC-J-C-N-ST-BH2	SUB-TNC-J-C-N-ST-BH2
2	SOCKET	BTNC-SKT-004-H	BTNC-SKT-004-G	BTNC-SKT-004-H	BTNC-SKT-004-G
3	INSULATOR	BNC5-INS-002			
4	INNER FERRULE	MCX-FER-012-F	MCX-FER-012-N		
5	OUTER FERRULE	MCX-FER-004-F	MCX-FER-004-N		
6	GASKET	BTNC-GKT-001			
7	LOCK WASHER	BTNC-LWAS-001-F	BTNC-LWAS-001-N		
8	HEX NUT	BTNC-NUT-001-F	BTNC-NUT-001-N		

PLATING SPECIFICATION
 -HF: 30µ" GOLD CENTER CONTACT,
 3µ" GOLD OUTER CONTACT
 -GF: 10µ" GOLD CENTER CONTACT,
 3µ" GOLD OUTER CONTACT
 -HN: 30µ" GOLD CENTER CONTACT,
 100µ" NICKEL OUTER CONTACT
 -GN: 10µ" GOLD CENTER CONTACT,
 100µ" NICKEL OUTER CONTACT
 (SEE TABLE 1)

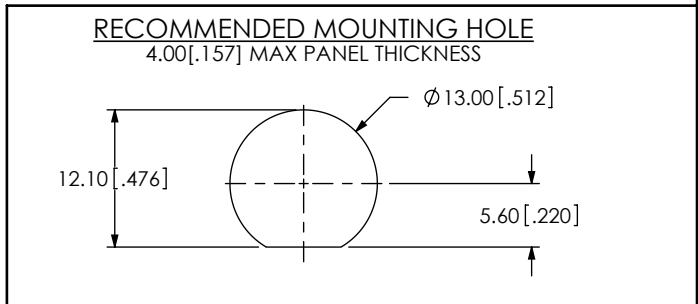
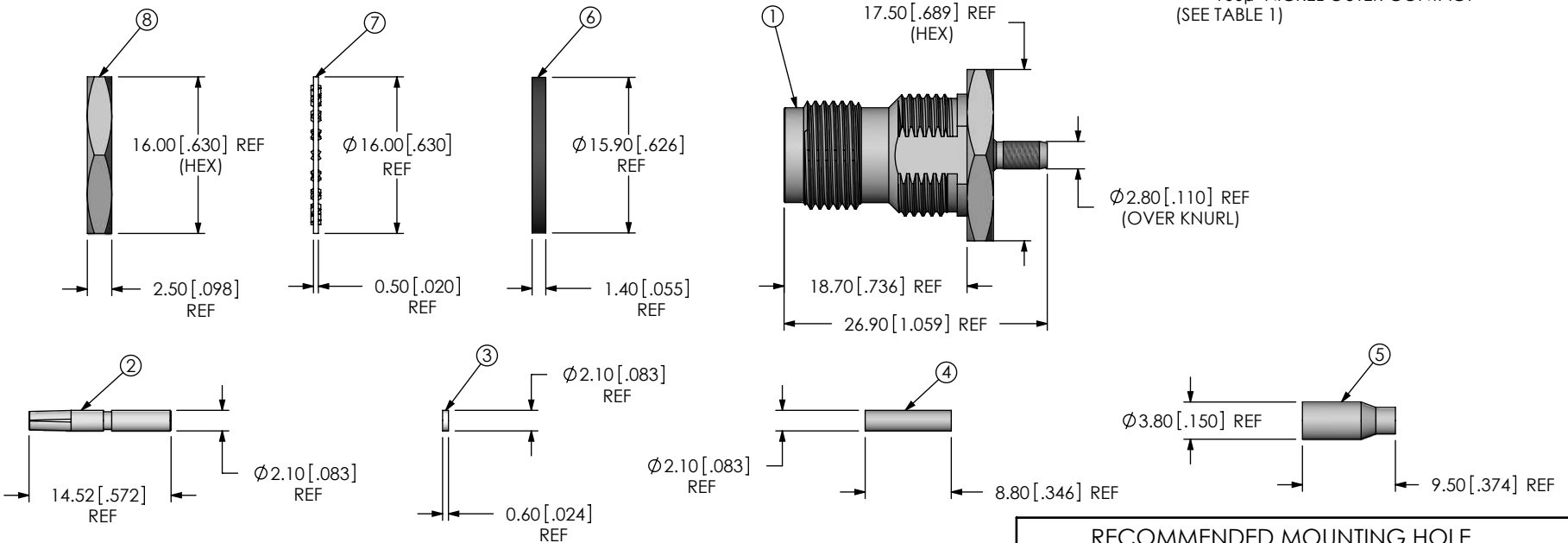

NOTES:
 1. NOTE DELETED.
 2. PRODUCT TO BE BULK PACKAGED PER PACKAGING STANDARD CO-RF-WI-3040-M.

UNLESS OTHERWISE SPECIFIED, DIMENSIONS ARE IN MILLIMETERS. TOLERANCES ARE: DECIMALS ANGLES X.X: ±0.3 [.01] 5° X.XX: ±0.13 [.005] X.XXX: ±0.051 [.0020]	* PROPRIETARY NOTE * THIS DOCUMENT CONTAINS CONFIDENTIAL AND PROPRIETARY INFORMATION AND ALL DESIGN, MANUFACTURING, REPRODUCTION, USE, PATENT RIGHTS AND SALES RIGHTS ARE EXPRESSLY RESERVED BY SAMTEC, INC. THIS DOCUMENT SHALL NOT BE DISCLOSED, IN WHOLE OR PART, TO ANY UNAUTHORIZED PERSON OR ENTITY NOR REPRODUCED, TRANSFERRED OR INCORPORATED IN ANY OTHER PROJECT IN ANY MANNER WITHOUT THE EXPRESS WRITTEN CONSENT OF SAMTEC, INC.	 520 PARK EAST BLVD, NEW ALBANY, IN 47150 PHONE: 812-944-6733 FAX: 812-948-5047 e-Mail: info@SAMTEC.com code 55322
MATERIAL: DO NOT SCALE DRAWING CABLE BODY, FERRULES, LOCK WASHER, HEX NUT: BRASS GASKET: SILICONE SOCKET: PHOS BRONZE DIELECTRIC: PTFE	SHEET SCALE: 3:2 DESCRIPTION: 50 OHM, TNC STRAIGHT SEALED JACK FOR RG 178 DWG. NO. TNC-J-C-XX-ST-BH2	BY: EMMA CHEN 08/25/2011 SHEET 1 OF 2

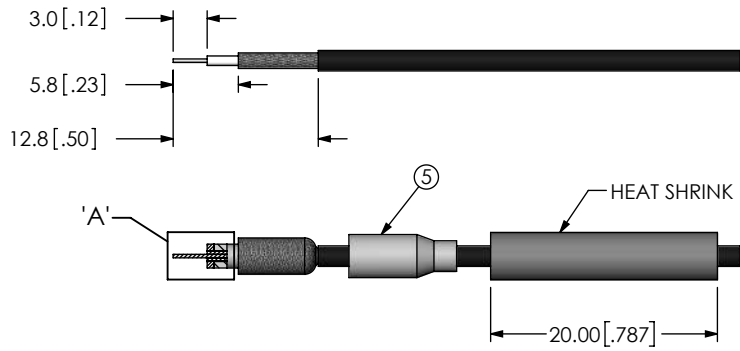

IN-PROCESS 1
STRIP CABLE AND TIN INNER CONDUCTOR

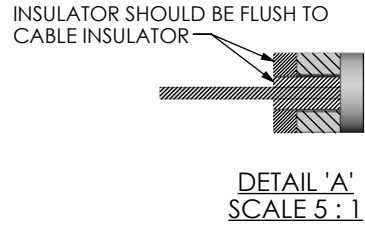

IN-PROCESS 2
ADD HEAT SHRINK TUBING & OUTER FERRULE FLARE SHIELD, ADD INSULATOR & INNER FERRULE



IN-PROCESS 3
SOLDER SIGNAL PIN

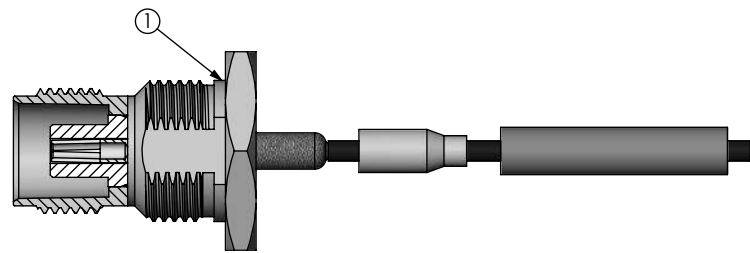

IN-PROCESS 4
ADD SUB ASSEMBLY

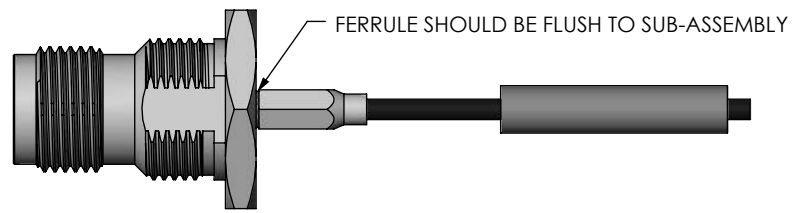

IN-PROCESS 5
CRIMP FERRULE
(USE RF CRIMP HAND TOOL #CAT-RF-FER-001 AND 0.136" INCH DESIGNATION DIE SIZE)

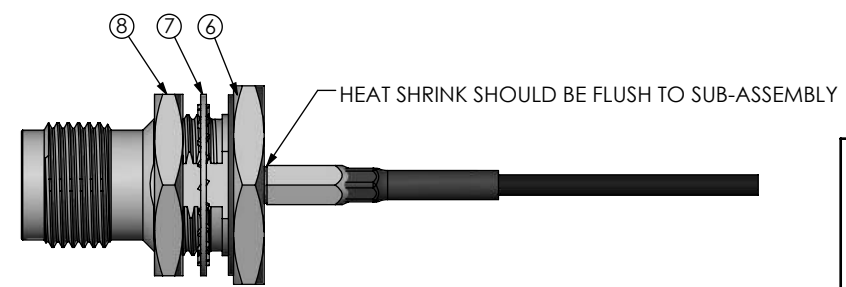

IN-PROCESS 6
ACTIVATE HEAT SHRINK TUBING & ADD GASKET

PROPRIETARY NOTE
THIS DOCUMENT CONTAINS CONFIDENTIAL AND PROPRIETARY INFORMATION AND ALL DESIGN, MANUFACTURING, REPRODUCTION, USE, PATENT RIGHTS AND SALES RIGHTS ARE EXPRESSLY RESERVED BY SAMTEC, INC. THIS DOCUMENT SHALL NOT BE DISCLOSED, IN WHOLE OR PART, TO ANY UNAUTHORIZED PERSON OR ENTITY NOR REPRODUCED, TRANSFERRED OR INCORPORATED IN ANY OTHER PROJECT IN ANY MANNER WITHOUT THE EXPRESS WRITTEN CONSENT OF SAMTEC, INC.

DO NOT SCALE DRAWING
SHEET SCALE: 3:2



DESCRIPTION:
50 OHM, TNC STRAIGHT SEALED JACK FOR RG 178
DWG. NO.

TNC-J-C-XX-ST-BH2

BY: EMMA CHEN 08/25/2011 SHEET 2 OF 2