

**Features**

- Low On-Resistance (16Ω typ) Minimizes Distortion and Error Voltages
- Low Glitching Reduces Step Errors in Sample-and-Holds. Charge Injection, 3pC typ
- Single Supply (+3V to +15V) or Split-Supply (±3V to ±8V) Operation
- Improved Second Sources for MAX381/MAX383/MAX385
- On-Resistance Matching Between Channels, 0.2 Ω typ
- On-Resistance Flatness, 1Ω typ
- Low Off-Channel Leakage, <2.5nA @ +85°C
- TTL/CMOS Logic Compatible
- Rail-to-Rail Analog Signal Dynamic Range
- Low Power Consumption <1μA

**Applications**

- Instrumentation, ATE
- Sample-and-Holds
- Audio Switching and Routing
- Telecommunication Systems
- PBX, PABX
- Battery-Powered Systems

**Description**

The PS381/PS383/PS385 are improved high precision, medium voltage analog switches designed to operate with +3V to ±8V power supplies.

The PS381 has two normally open (NO) switches. The PS383 is a dual, single-pole double-throw (SPDT) switch. The PS385 is a dual, double-pole single-throw (DPST) function. Each switch conducts current equally well in either direction when on. In the off state each switch blocks voltages up to the power-supply rails.

With ±5V power supplies, the PS381/PS383/PS385 guarantee <30Ω on-resistance. On-resistance matching between channels is within 2Ω. On-resistance flatness is less than 4Ω over the specified range. All three devices feature low leakage currents (<2 pA @ 25°C, <2.5nA @ +85°C) and fast switching speeds (t<sub>ON</sub> <130ns). Break-before-make switching action protects against momentary crosstalk (PS383).

These switches are fully specified for single +5V operation, with <45Ω R<sub>ON</sub>, <2Ω R<sub>ON</sub> match, and <4Ω R<sub>ON</sub> flatness.

For operation below 5V the PI5A381A/PI5A383A/PI5A385A are also recommended.

**Functional Diagrams, Pin Configurations, and Truth Tables**

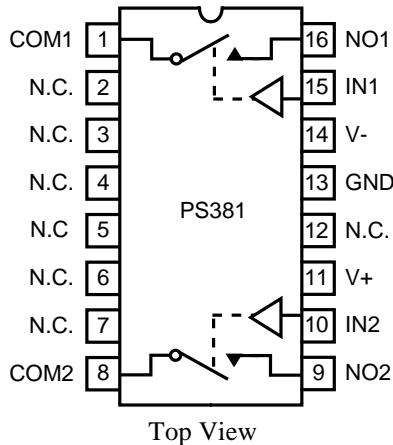

N.C = No Connect.

PS381	
Logic	Switch
0	OFF
1	ON

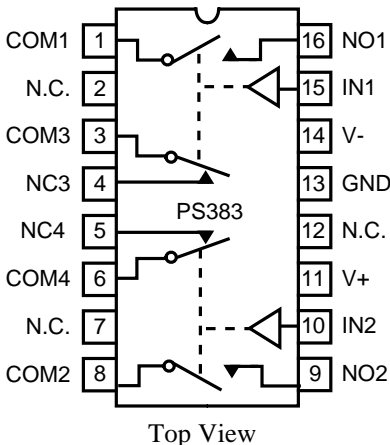

Switches shown for logic "0" input

PS383		
Logic	SW3, SW4	SW1, SW2
0	ON	OFF
1	OFF	ON

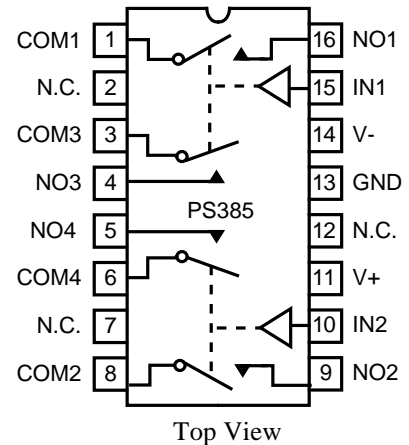

PS385	
Logic	Switch
0	OFF
1	ON

### Absolute Maximum Ratings

Voltages Referenced to V-

V+ .....	-0.3V to +17V
GND .....	-0.3V to +17V
GND .....	-0.3V to (V+) +0.3V
V <sub>IN</sub> , V <sub>COM</sub> , V <sub>NC</sub> , V <sub>NO</sub> (Note 1) .....	(V-) -2V to (V+) +2V or 30mA, whichever occurs first
Current (any terminal) .....	30mA
Peak Current, COM, NO, NC (pulsed at 1ms, 10% duty cycle) .....	100mA
ESD per Method 3015.7 .....	>2000V

### Thermal Information

Continuous Power Dissipation (T <sub>A</sub> = +70°C)	
Plastic DIP (derate 10.5mW/°C above +70°C) .....	800mW
Narrow SO (derate 8.7mW/°C above +70°C) .....	650mW
Storage Temperature .....	-65°C to +150°C
Lead Temperature (soldering, 10s) .....	+300°C

**Note 1:** Signals on NC, NO, COM, or IN exceeding V+ or V- are clamped by internal diodes. Limit forward diode current to maximum current rating

**Caution:** Stresses beyond those listed under “Absolute Maximum Ratings” may cause permanent damage to the device. This is a stress only rating and operation of the device at these or any other conditions beyond those indicated in the operational sections of this specification is not implied.

### Electrical Specifications - Dual Supplies

(V<sub>±</sub> = ± 5V ±10%, GND = 0V, V<sub>INH</sub> = 2.4V, V<sub>INL</sub> = 0.8V)

Parameter	Symbol	Conditions	Temp. (°C)	Min <sup>(2)</sup>	Typ <sup>(1)</sup>	Max <sup>(2)</sup>	Units
<b>Analog Switch</b>							
Analog Signal Range <sup>(3)</sup>	V <sub>ANALOG</sub>		Full	V-		V+	V
On Resistance	R <sub>ON</sub>	V+ = 4.5V, V- = -4.5V, V <sub>NO</sub> or V <sub>NC</sub> = ±3.5V I <sub>COM</sub> = -10mA,	25		16	30	Ω
			Full			40	
On-Resistance Match Between Channel <sup>(4)</sup>	ΔR <sub>ON</sub>	V <sub>NO</sub> or V <sub>NC</sub> = ±3V, I <sub>COM</sub> = -10mA, V+ = 5V, V- = -5V	25		0.2	2	Ω
			Full			4	
On-Resistance Flatness <sup>(5)</sup>	R <sub>FLAT(ON)</sub>	V+ = 5V, V- = -5V, I <sub>COM</sub> = -10mA, V <sub>NO</sub> or V <sub>NC</sub> = ±3.5V	25		1	4	Ω
			Full			6	
NO or NC Off Leakage Current <sup>(6)</sup>	I <sub>NO(OFF)</sub> or I <sub>NC(OFF)</sub>	V+ = 5.5V, V- = -5.5V, V <sub>COM</sub> = ± 4.5V, V <sub>NC</sub> or V <sub>NO</sub> = +4.5V	25	-0.1	-0.001	0.1	nA
			Full	-2.5		2.5	
COM Off Leakage Current <sup>(6)</sup>	I <sub>COM(OFF)</sub>	V+ = 5.5V, V- = -5.5V V <sub>COM</sub> = ± 4.5V, V <sub>NO</sub> or V <sub>NC</sub> = +4.5V	25	-0.1	-0.001	0.1	nA
			Full	-2.5		2.5	
COM On Leakage Current <sup>(7)</sup>	I <sub>COM(ON)</sub>	V+ = 5.5V, V- = -5.5V, V <sub>COM</sub> = ±4.5V V <sub>NO</sub> or V <sub>NC</sub> = ±4.5V	25	-0.2	0.002	0.2	nA
			Full	-5		5	

**Electrical Specifications - Dual Supplies** (continued)

( $V \pm \pm 5V \pm 10\%$ , GND = 0V,  $V_{INH} = 2.4V$ ,  $V_{INL} = 0.8V$ )

Parameter	Symbol	Conditions	Temp (°C)	Min <sup>(1)</sup>	Typ <sup>(2)</sup>	Max <sup>(1)</sup>	Units
<b>Logic Input</b>							
Input Current with Input Voltage High	$I_{INH}$	$V_{IN} = 2.4V$ , all others = 0.8V	Full	-0.5	0.005	0.5	$\mu A$
Input Current with Input Voltage Low	$I_{INL}$	$V_{IN} = 0.8V$ , all others = 2.4V		-0.5	0.005	0.5	
Logic High Input Voltage	$V_{AH}$			2.4			V
Logic Low Input Voltage	$V_{AL}$					0.8	
<b>Dynamic</b>							
Turn-On Time	$t_{ON}$	$V_{COM} = \pm 3V$ , Figure 2	25		51	130	ns
			Full			175	
Turn-Off Time	$t_{OFF}$		25		29	75	
			Full			100	
Break-Before-Make TimeDelay	$t_D$	PS383 only, Figure 3	25	10	20		
Charge Injection	Q	$C_L = 1nF$ , $V_{GEN} = 0V$ , $R_{GEN} = 0\Omega$ , Figure 4	25		2	5	pC
Off Isolation <sup>(7)</sup>	OIRR	$R_L = 50\Omega$ , $C_L = 5pF$ , $f = 1MHz$ , Figure 5			-65		dB
Crosstalk <sup>(8)</sup>	$X_{TALK}$	$R_L = 50\Omega$ , $C_L = 5pF$ , $f = 1MHz$ , Figure 6			-90		
NC or NO Off Capacitance	$C_{(OFF)}$	$f = 1MHz$ , Figure 7				12	pF
COM Off Capacitance	$C_{COM(OFF)}$	$f = 1MHz$ , Figure 7				12	
COM On Capacitance	$C_{COM(ON)}$	$f = 1MHz$ , Figure 8				25	
<b>Supply</b>							
Power-Supply Range	V+, V-			$\pm 3$		$\pm 8$	V
Positive Supply Current	I+	$V+ = 5.5V$ , $V- = -5.5V$ , $V_{IN} = 0V$ or $V+$ , all channels on or off	Full	-1		1	$\mu A$
Negative Supply Current	I-			-1		1	

**Notes:**

1. The algebraic convention, where the most negative value is a minimum and the most positive is a maximum, is used in this data sheet.
2. Typical values are for DESIGN AID ONLY, not guaranteed or subject to production testing.
3. Guaranteed by design
4.  $\Delta R_{ON} = \Delta R_{ON} \text{ max} - \Delta R_{ON} \text{ min}$
5. Flatness is defined as the difference between the maximum and minimum value of on-resistance measured.
6. Leakage parameters are 100% tested at maximum rated hot temperature and guaranteed by correlation at +25°C.
7. Off Isolation =  $20 \log_{10} [ V_{COM} / (V_{NO} \text{ or } V_{NO}) ]$ . See figure 5.
8. Between any two switches. See figure 6.

**Electrical Specifications - Single +5V Supply**

(V+ = +5V ±10%, V- = 0V, GND = 0V, V<sub>INH</sub> = 2.4V, V<sub>INL</sub> = 0.8V)

Parameter	Symbol	Conditions	Temp°C	Min. <sup>(2)</sup>	Typ. <sup>(2)</sup>	Max. <sup>(2)</sup>	Units
<b>Analog Switch</b>							
Analog Switch Range <sup>(3)</sup>	V <sub>ANALOG</sub>		Full	0		V+	V
On-Resistance	R <sub>ON</sub>	V+ = 5.0V, V- = 0V I <sub>COM</sub> = -10mA, V <sub>NO</sub> or V <sub>NC</sub> = 3.5V	25		25	45	Ω
			Full			60	
On-Resistance Match Between Channels <sup>(4)</sup>	ΔR <sub>ON</sub>	V+ = 5V, V <sub>COM</sub> = -10mA, V <sub>NO</sub> or V <sub>NC</sub> = 3V	25		0.5	2	
			Full			4	
On-Resistance Flatness <sup>(5)</sup>		V+ = 5V, V- = 0V, I <sub>COM</sub> = -10mA, V <sub>NO</sub> or V <sub>NC</sub> = 1V, 4V	25		1	4	
			Full			6	
NO or NC Off Leakage Current <sup>(9)</sup>	I <sub>NO(OFF)</sub> or I <sub>NC(OFF)</sub>	V+ = 5.5V, V <sub>COM</sub> = 0V, V <sub>NO</sub> or V <sub>NC</sub> = 4.5V	25	-0.1	0.001	0.1	nA
			Full	-2.5		2.5	
COM Off Leakage Current <sup>(9)</sup>	I <sub>COM(OFF)</sub>	V+ = 5.5V, V <sub>COM</sub> = 4.5V, V <sub>NO</sub> or V <sub>NC</sub> = 0V	25	-01	0.001	0.1	
			Full	-2.5		2.5	
COM On Leakage Current <sup>(9)</sup>	I <sub>COM(ON)</sub>	V <sub>COM</sub> = 4.5V, V <sub>NO</sub> or V <sub>NC</sub> = 4.5V, V+ = 5.5V	25	-0.2	-0.002	0.2	
			Full	-5		5	
<b>Dynamic</b>							
Turn-On-Time <sup>(3)</sup>	t <sub>ON</sub>	V <sub>COM</sub> = 3V, Figure 2	25		63	170	ns
			Full			240	
Turn-Off-Time <sup>(3)</sup>	t <sub>OFF</sub>		25		34	50	
			Full			100	
Break-Before-Make Time Delay <sup>(3)</sup>	t <sub>D</sub>	PS383 only	25	10	20		
Charge Injection <sup>(3)</sup>	Q	C <sub>L</sub> = 1nF, V <sub>GEN</sub> = 0V, R <sub>GEN</sub> = 0Ω, Figure 4	25		0	5	pC
<b>Supply</b>							
Positive Supply Current	I+	All channels on or off, V <sub>IN</sub> = 0V or V+, V+ = 3.6V, V- = 0V	Full	-1		1	μA
Negative Supply Current	I-			-1		1	

### Electrical Specifications - Single +3.3V Supply

(V+ = +3V to 3.6V, V- = 0V, GND = 0V, V<sub>NH</sub> = 2.4V, V<sub>INL</sub> = 0.8V)

Parameter	Symbol	Conditions	Temp (°C)	Min. <sup>(1)</sup>	Typ. <sup>(2)</sup>	Max. <sup>(1)</sup>	Units
<b>Analog Switch</b>							
Analog Switch Range <sup>(3)</sup>	V <sub>ANALOG</sub>		Full	0		V+	V
Channel On-Resistance	R <sub>ON</sub>	V+ = 3V, I <sub>COM</sub> = -10mA V <sub>NO</sub> = V <sub>NC</sub> = 1.5V	25		62	150	Ω
			Full			200	
<b>Dynamic</b>							
Turn-On Time <sup>(3)</sup>	t <sub>ON</sub>	V <sub>COM</sub> = 1.5V, Figure 2	25			400	ns
Turn-Off Time <sup>(3)</sup>	t <sub>OFF</sub>					150	
Break-Before-Make Time Delay	t <sub>D</sub>	PS383 only	25	10	20		
Charge Injection	Q	C <sub>L</sub> = 1nF, V <sub>GEN</sub> = 0V, R <sub>GEN</sub> = 0Ω	25			5	pC
<b>Supply</b>							
Power-Supply Range	V+	All channels on or off, V <sub>IN</sub> = 0V or V+, V+ = 3.6V, V- = 0.5V	Full	2.7		16	V
Positive Supply Current	I+			-1		1	μA
Negative Supply Current	I-			-1		1	

#### Notes:

1. The algebraic convention, where the most negative value is a minimum and the most positive is a maximum, is used in this data sheet.
2. Typical values are for DESIGN AID ONLY, not guaranteed or subject to production testing.
3. Guaranteed by design
4.  $\Delta R_{ON} = \Delta R_{ON \text{ max}} - \Delta R_{ON \text{ min}}$
5. Flatness is defined as the difference between the maximum and minimum value of on-resistance measured.
6. Leakage parameters are 100% tested at maximum rated hot temperature and guaranteed by correlation at +25°C.
7. Off Isolation =  $20 \log_{10} [ V_{COM} / (V_{NO} \text{ or } V_{NO}) ]$ . See figure 5.
8. Between any two switches. See figure 6.
9. Leakage testing at single-supply is guaranteed by testing with dual supplies.

**Typical Operating Characteristics** ( $T_A = +25^\circ\text{C}$ , unless otherwise noted)

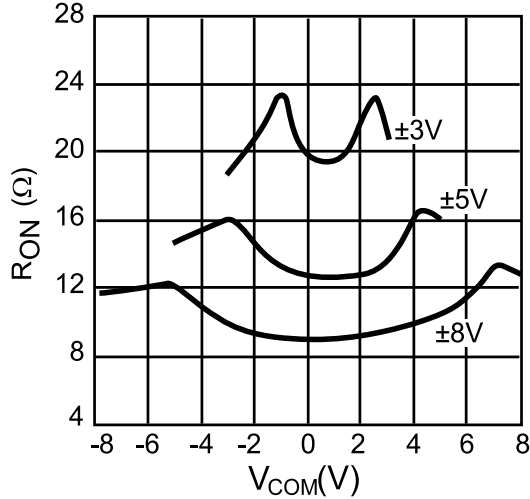
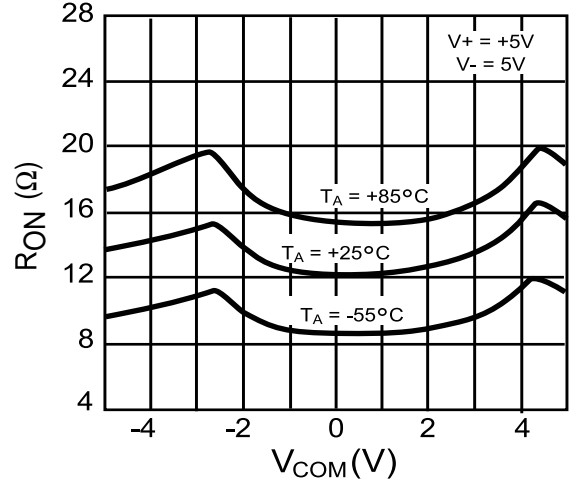
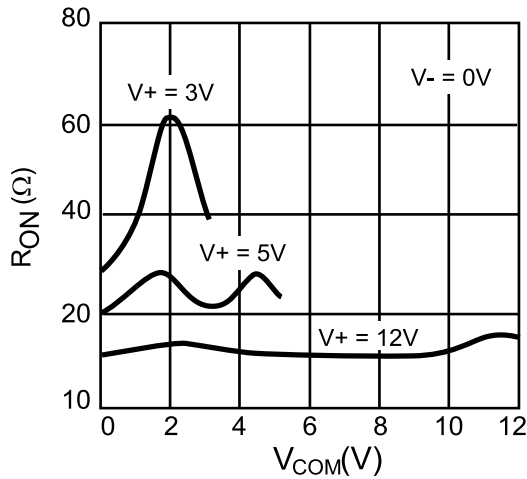
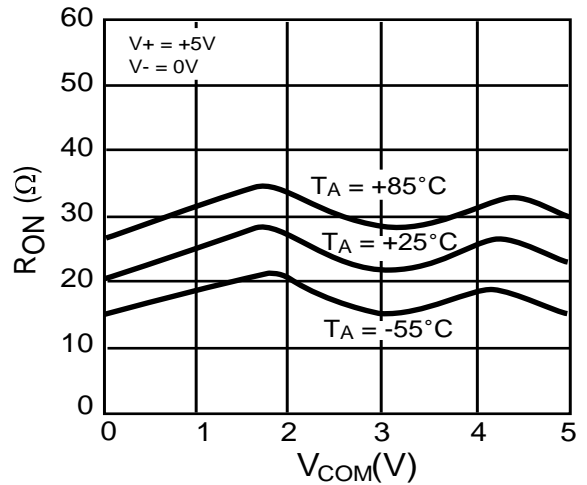
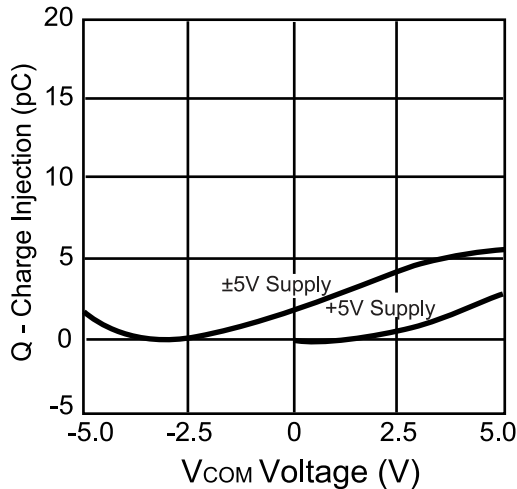
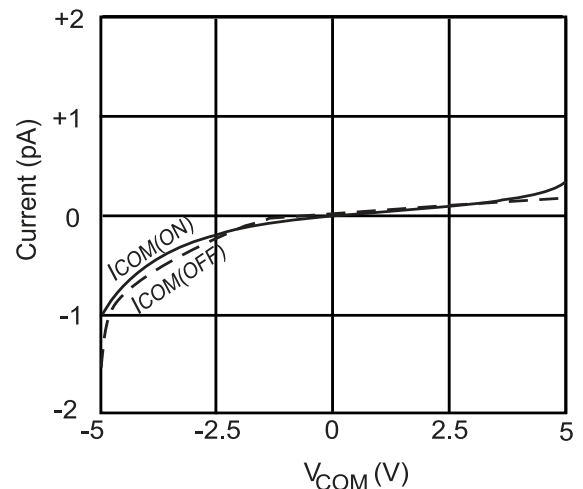
 **$R_{ON}$  vs.  $V_{COM}$  & Supply Voltages**

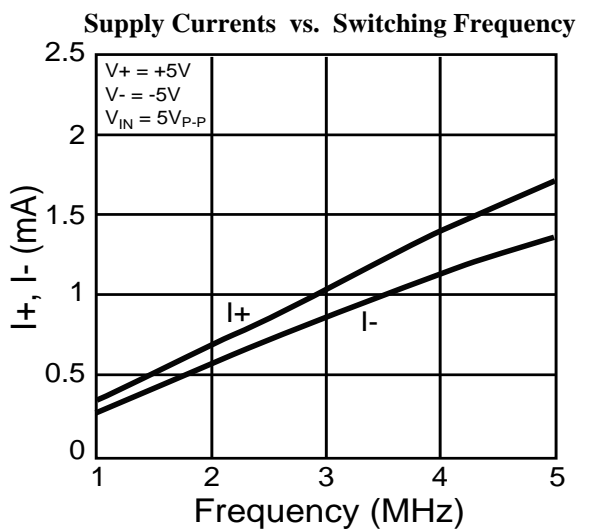
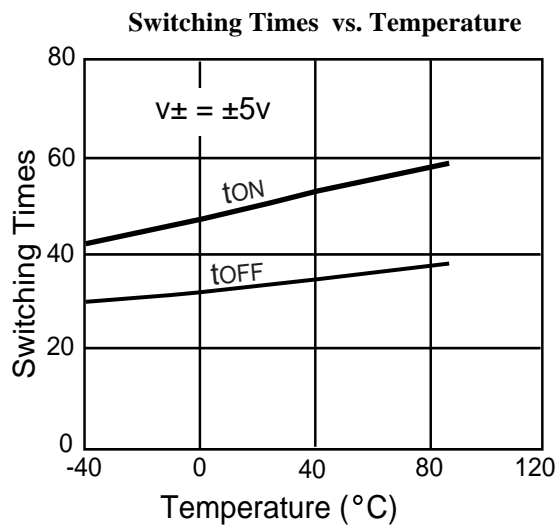
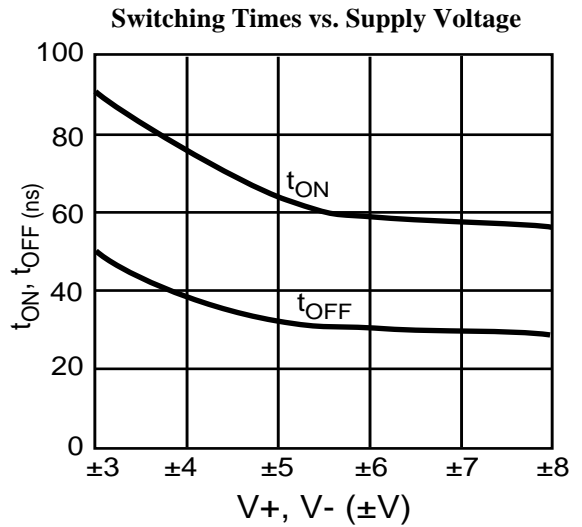
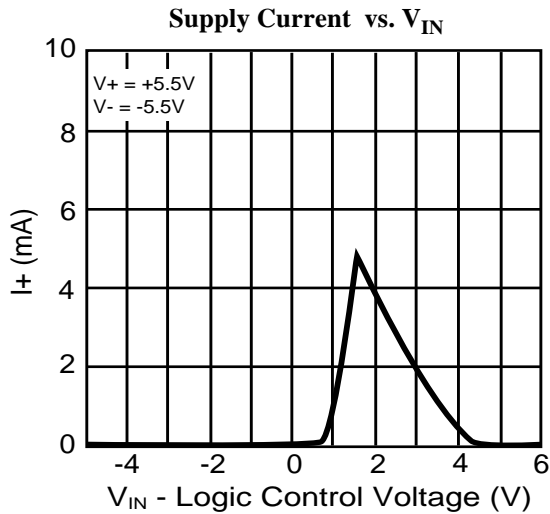
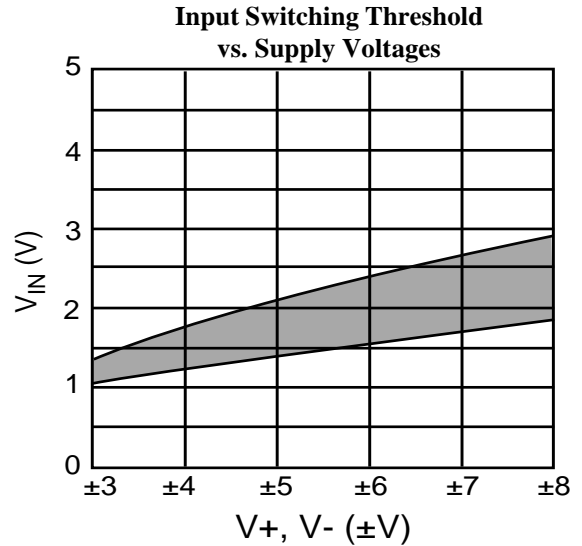
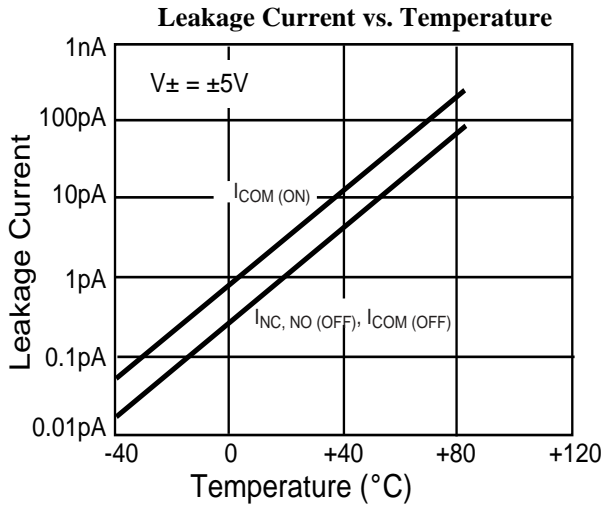
 **$R_{ON}$  vs.  $V_{COM}$  & Supply Voltages**

 **$R_{ON}$  vs.  $V_{COM}$  (Single Supply)**

 **$R_{ON}$  vs.  $V_{COM}$  and Temperature (Single Supply)**

**Charge Injection vs. Analog Voltage**

**Leakage Current vs.  $V_{COM}$** 

**Typical Operating Characteristics (continued)**

Test Circuits/Timing Diagrams

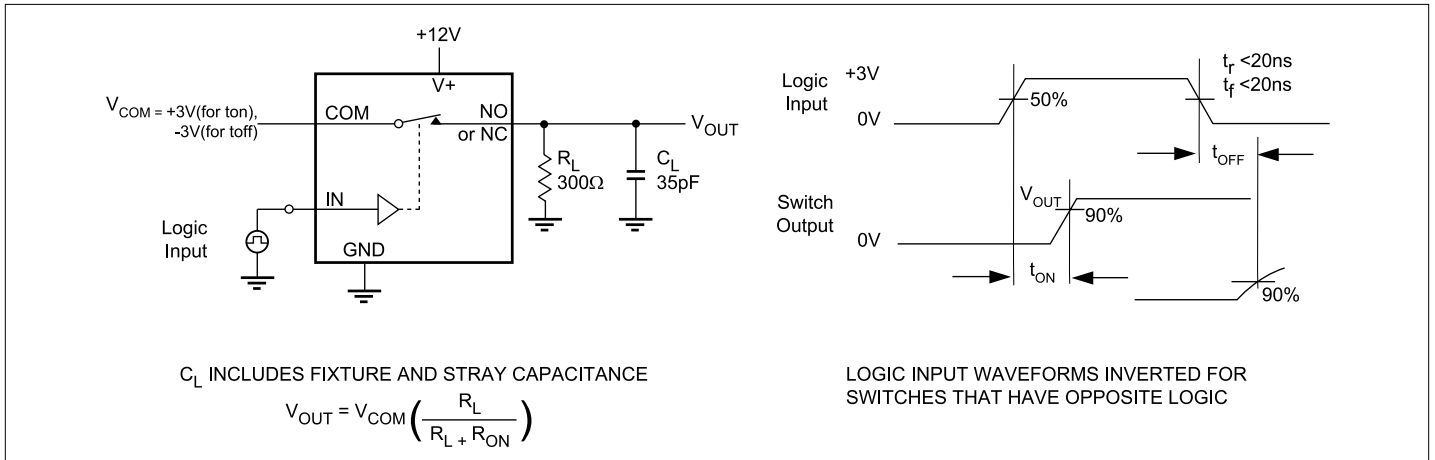

Figure 2. Switching Time

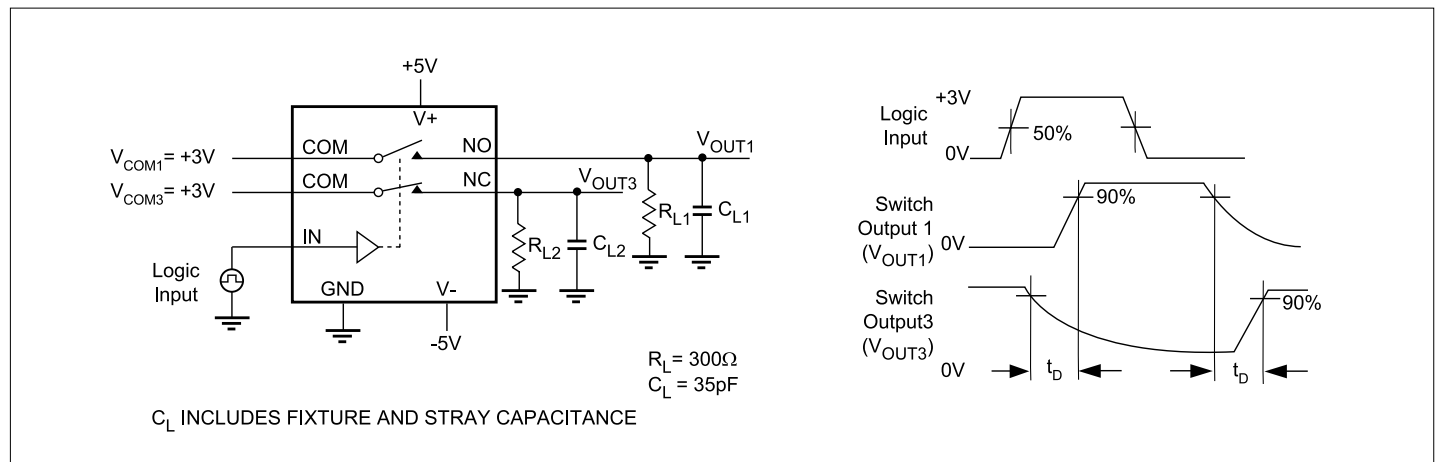

Figure 3. Break-Before-Make Interval (PS383 only)

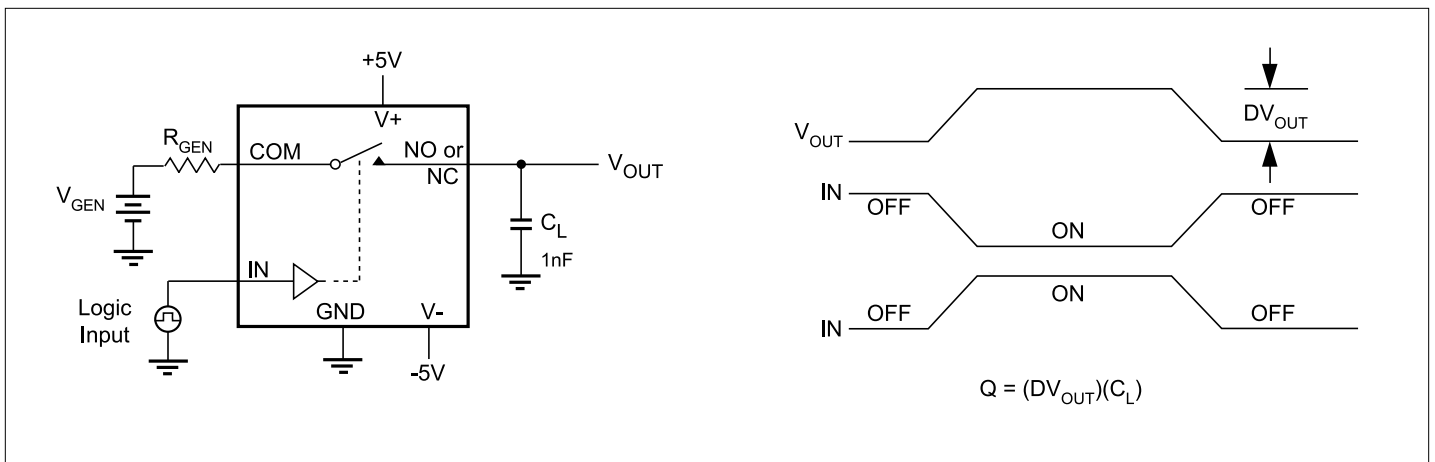

Figure 4. Charge Injection



Test Circuits/Timing Diagrams (continued)

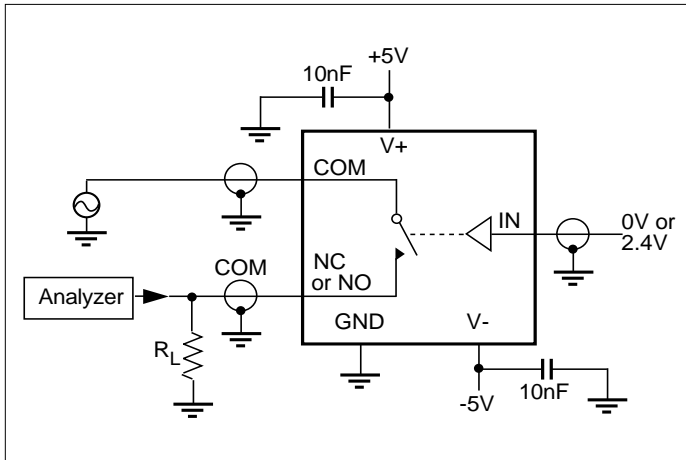

Figure 5. Off Isolation

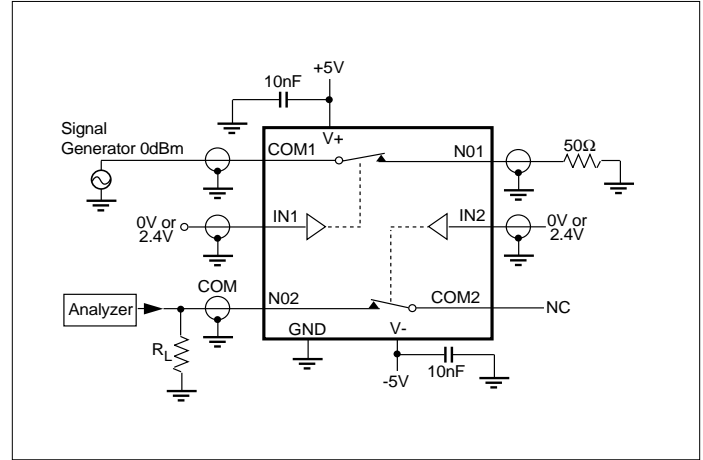

Figure 6. Crosstalk

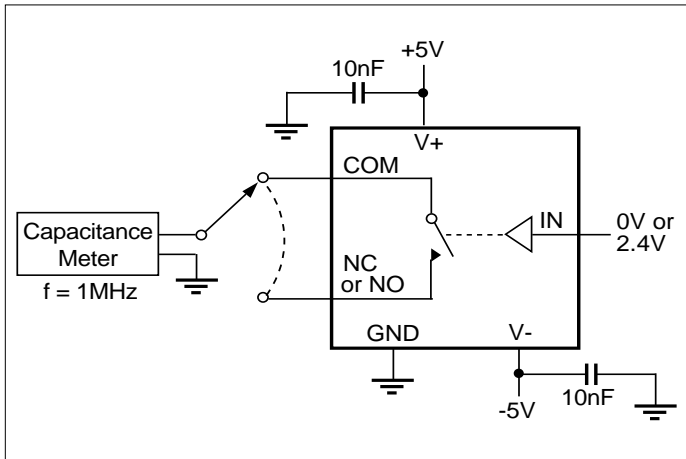

Figure 7. Channel-Off Capacitance

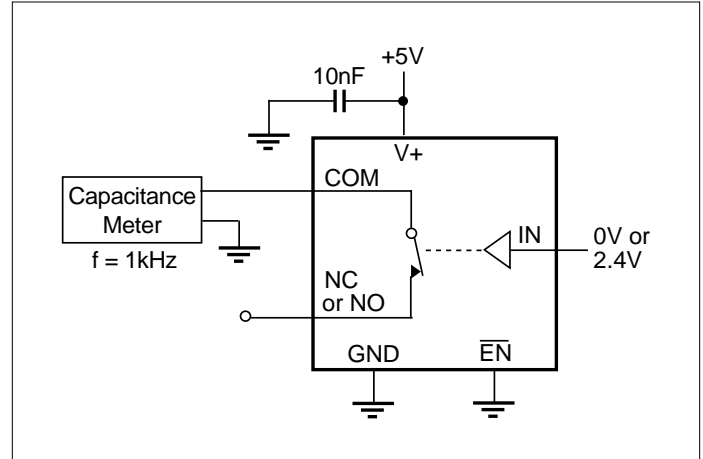

Figure 8. Channel-On Capacitance

Ordering Information

Part	Temp. Range	Package
PS381CPE	0°C to +70°C	16 Plastic DIP
PS381CSE	0°C to +70°C	16 Narrow SO
PS381EPE	-40°C to +85°C	16 Plastic DIP
PS381ESE	-40°C to +85°C	16 Narrow SO
PS383CPE	0°C to +70°C	16 Plastic DIP
PS383CSE	0°C to +70°C	16 Narrow SO
PS383EPE	-40°C to +85°C	16 Plastic DIP
PS383ESE	-40°C to +85°C	16 Narrow SO
PS385CPE	0°C to +70°C	16 Plastic DIP
PS385CSE	0°C to +70°C	16 Narrow SO
PS385EPE	-40°C to +85°C	16 Plastic DIP
PS385ESE	-40°C to +85°C	16 Narrow SO