

THIS DRAWING IS UNPUBLISHED. RELEASED FOR PUBLICATION
 © COPYRIGHT - By - ALL RIGHTS RESERVED.

LOC	DIST	REVISIONS					
AF	50	P	LTR	DESCRIPTION	DATE	DWN	APVD
				D1 REVISED PER ECO-14-017598	04DEC14	JR	DH

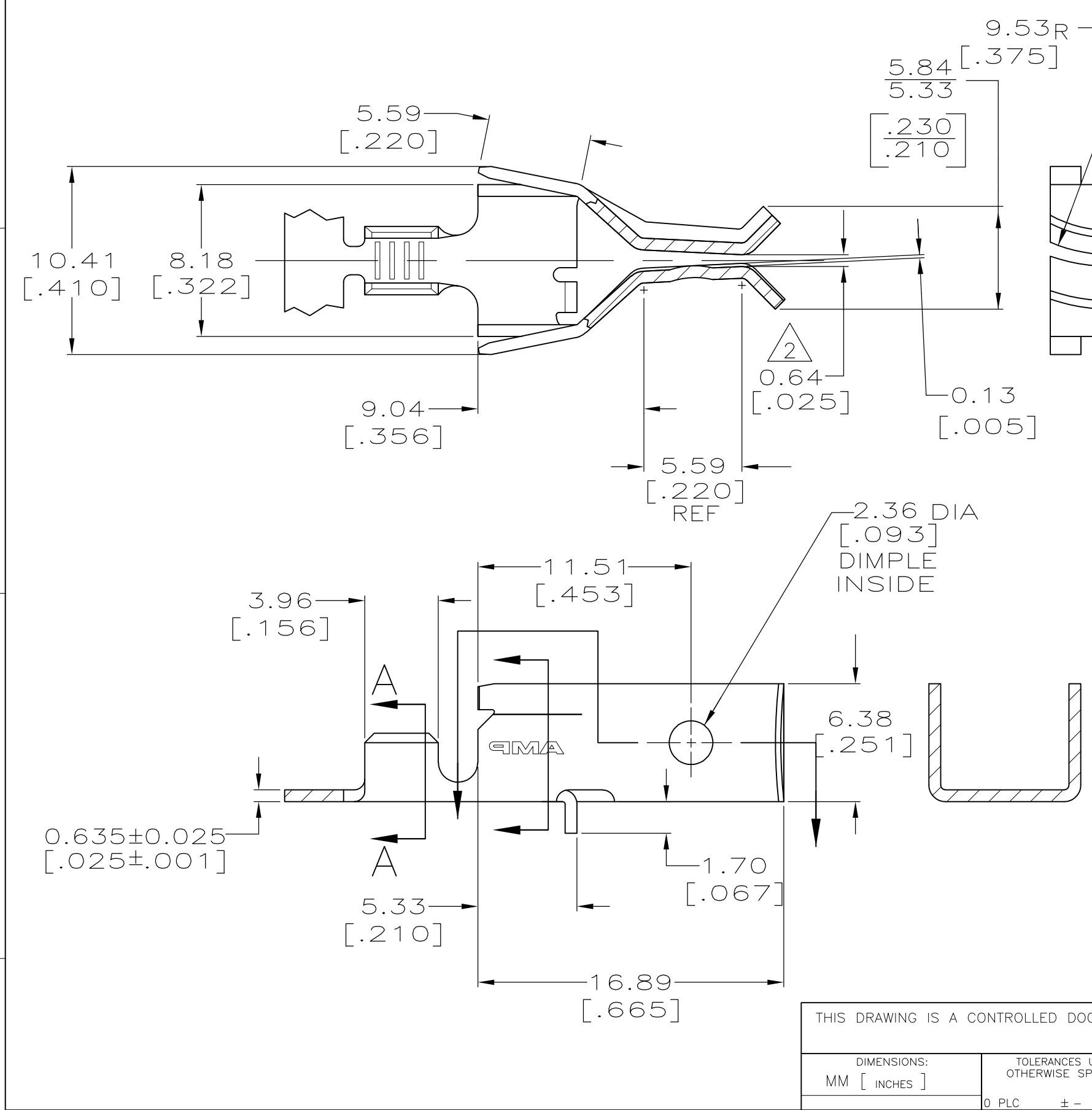

- 1 CONTINUOUS STRIP ON REEL.
- △ 2 DIMENSION NOT TO EXCEED 1.01 [.040] AFTER 6 INSERTIONS OF A MATING BLADE.
- 3 OVERLAP SPLICE USED

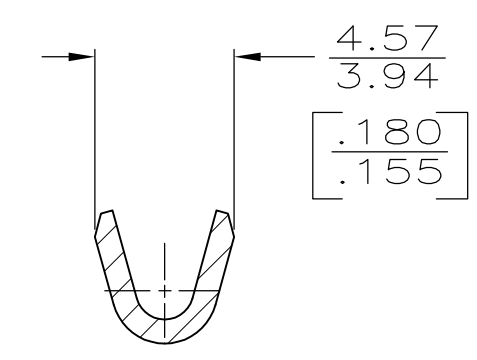

SECTION A-A
SCALE 5:1

0.00381 [.000150] MIN SILVER PLATE	[18-14] AWG	63863-2
0.00203 [.000080] MIN TIN PLATE	[18-14] AWG	63863-1
FINISH	WIRE RANGE	PART NO.

THIS DRAWING IS A CONTROLLED DOCUMENT.		DWN 20/JUL/95 PHILLIP M. FORTNEY	STE TE Connectivity	
		CHK 20/JUL/95 JEFF R. RUTH		
DIMENSIONS: MM [INCHES]		APVD 20/JUL/95 DENNIS SCHWENK	NAME	
TOLERANCES UNLESS OTHERWISE SPECIFIED:		PRODUCT SPEC		
0 PLC ± -		APPLICATION SPEC		
1 PLC ± -		SIZE		
2 PLC ± 0.25 [.010]		CAGE CODE		
3 PLC ± -		DRAWING NO		
4 PLC ± -		RESTRICTED TO		
ANGLES ± -		A3 00779 C-63863		
MATERIAL H04 PHOS BRONZE		WEIGHT -		
FINISH SEE TABLE		CUSTOMER DRAWING		
		SCALE 4:1		SHEET 1 OF 1
				REV D1