

MULTILAYER CERAMIC CHIP CAPACITORS

- GMC SERIES -

APPLICATIONS

- Can be used on surface mount assembly equipment
- Our fully integrated manufacturing and total quality control systems ensure unprecedented high standards of quality and reliability.

FEATURES

- Large capacitance values in small sizes
- Excellent high frequency characteristics

CHIP CAPACITOR SELECTION



DIELECTRIC TYPE

COG (NPO) - Capacitance change with temperature is 0-30ppm/°C which is less than -0.3%/°C from -55°C to +125°C. Typical capacitance change with life is less than -0.1 % for NPOs, one-fifth that shown by most other dielectrics. NPO formulations show no aging characteristics.

Ultra stable class I dielectric: linear temperature coefficient, low loss, negligible change of electrical properties with time, voltage and frequency.

OPERATING TEMPERATURE RANGE	TEMPERATURE COEFFICIENT	DISSIPATION FACTOR	INSULATION RESISTANCE	DIELECTRIC WITHSTANDING VOLTAGE	AGING RATE	TEST PARAMETERS
-55°C to +125 C	0±30ppm°C	0.1% Max, 0.02% Typical	•>100GΩ or 1000ΩF •125°C VDCW: 10GΩF or 100ΩF whichever is less	3 X VDCW	0% per decade hour	• C<1000pF f=1MHz V=1.0Vrms ±0.2Vrms T=25°C • C>1000pF f=1KHz V=1.0Vrms ±0.2Vrms T=25°C

Stable class II dielectric

OPERATING TEMPERATURE RANGE	TEMPERATURE COEFFICIENT	DISSIPATION FACTOR	INSULATION RESISTANCE	DIELECTRIC WITHSTANDING VOLTAGE	AGING RATE	TEST PARAMETERS
X7R: -55C to+125C X5R: -55C to+85C X6S: -55C to+105C X7S: -55C to+125C	± 15% ± 15% ± 22% ± 22%	2.5% Max, 1.8% Typical	•25°C, VdCW: >100GΩF or 1000ΩF, whichever is less •125°C, VdCW: >100GΩF or1000ΩF whichever is less	2.5 X VDCW	<2% per decade hour	• 1KHz 1.0Vrms +/-0.2Vrms 25c Values > or = to 10µF 0.5+/-0.1 VDCW @120Hz

Z5U - Despite their capacitance instability, Z5U formulations are very popular because of their small size, temperature range low ESL, low ESR and excellent frequency response. These features are particularly important for decoupling application where only a minimum capacitance value is required.

Y5V - Y5V formulations are for general purpose use in a limited temperature range. They have a wide temperature characteristic of +22% - 82% capacitance change over the operating temperature range of -30°C to +85°C. Y5Vs high dielectric constant allows the manufacture of very high capacitance values (up to 100µF) in small physical sizes.

High capacitance per unit volume: general purpose product

OPERATING TEMPERATURE RANGE	TEMPERATURE COEFFICIENT	TEMPERATURE VOLTAGE COEFFICIENT (Δc MAX @ VdCW)	DISSIPATION FACTOR	INSULATION RESISTANCE	DIELECTRIC WITHSTANDING VOLTAGE	AGING RATE	TEST PARAMETERS
-30°C to +85°C	+22% -82%	N/A	3.0% Max, 2.0% Typical	•10GΩ or 100ΩF whichever is less, 25°C, VdCW	2.5 X VdCW	3.0% per decade hour	• 1 KHz, 1 Vrms 25°C values > or = to 10uF 1.0Vrms 120Hz

CONSTRUCTION

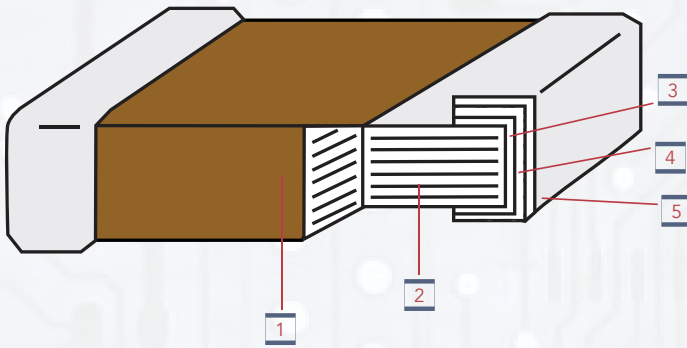

NO.	NAME	CLASS I DIELECTRIC	CLASS II DIELECTRIC
1	Ceramic Material	CaZrO ₃	BaTiO ₃
2	Inner Electrode	Ni	Ni
3	Inner layer	Cu	Cu
4	Middle layer	Ni	Ni
5	Outer layer	Sn	Sn

CAPACITANCE VALUE & TOLERANCE

Determined by circuit requirements. Note that chip prices decrease with lower capacitance value and looser tolerance.

CAPACITOR SIZE

Select the smallest unit permitted by the circuit constraints that provides the required capacitance and voltage rating. All Cal-Chip capacitors conform to EIA specifications.

VOLTAGE

Determined by circuit requirements.

CAPACITOR TERMINATION

Nickel barrier is standard and recommended for units exposed to repeated solder cycles, to minimize leaching of the termination.

REFLOW SOLDERING CONDITIONS

The lead-free termination MLCCs are not only to be used on SMT against lead-free solder paste, but also suitable against lead-containing solder paste. If the optimized solder joint is requested, increasing soldering time, temperature and concentration of N₂ within oven are recommended.

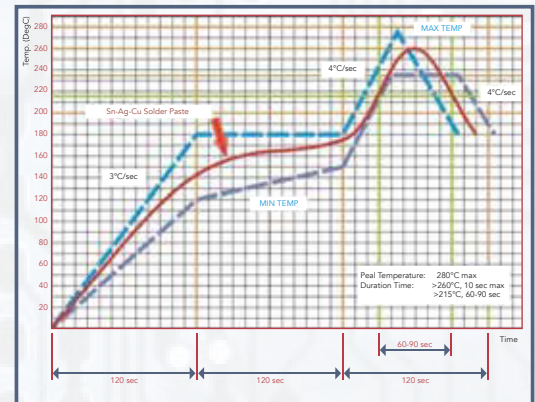

PART NUMBER GUIDE

GMC	21	CG	102	J	50	NT	D
PRODUCT TYPE	DIMENSIONS	DIELECTRIC	CAPACITANCE	TOLERANCE	VOLTAGE DC	TERMINATION	PACKAGING CODE
01: 1005 02: 0201 04: 0402 10: 0603 21: 0805 31: 1206	32: 1210 40: 1808 43: 1812 45: 1825 55: 2220 57: 2225	CG: COG/NPO X7R X5R X7S X6S Y5V Z5U	0R5: 0.5pF 5R0: 5.0pF R75: 0.75pF 100: 10pF 101: 100pF 102: 1000pF 103: .01uF 104: .1uF 105: 1.0uF 106: 10uF 107: 100uF	B: +/-1pF C: +/-25pF D: +/-5pF F: +/-1% G: +/-2% J: +/-5% K: +/-10% M: +/-20% Z: -20%/+80%	4R0: 4.0V 6R3: 6.3V 10: 10V 16: 16V 25: 25V 35: 35V 50: 50V 63: 63V 100: 100V 200: 200V	NT: Sn/Ni PT: Pd/Ag	Blank: 7" reel D: See page 19 & 20 G: See page 19 & 20 Q: See page 19 & 20

DIELECTRIC		NPO/COG																													
DIMENSION (MM)		GMC01					GMC02				GMC04						GMC10				GMC21						GMC31				
L	W	0.4 ± 0.02					0.6 ± 0.03				1.0 ± 0.05						1.6 ± 0.2				2.0 ± 0.3						3.2 ± 0.3				
BW	0.2 ± 0.02					0.3 ± 0.03				0.5 ± 0.05						0.8 ± 0.2				1.25 ± 0.2						1.6 ± 0.2					
	0.07 ~ 0.14					0.15 ± 0.05				0.1 ~ 0.35						0.1 ~ 0.4				0.25 ~ 0.75						0.25 ~ 0.75					
RATED VOLTAGE		6.3	10	16	25	50	16	25	50	100	6.3	10	16	25	50	100	200	25	50	100	200	10	16	25	50	100	200	25	50	100	200
CAP. RANGE																															
9.8pF	9R8	A	A	A	A		C	C	C	C	H	H	H	H	H	H	L	L	L	L											
9.9	9R9	A	A	A	A		C	C	C	C	H	H	H	H	H	H	L	L	L	L											
10	100	A	A	A	A	A	C	C	C	C	H	H	H	H	H	H	H	L	L	L	L	J	J	J	J	J	J	L	L	L	L
11	110	A	A	A	A	A	C	C	C		H	H	H	H	H		L	L	L	L	J	J	J	J	J	J	L	L	L	L	
12	120	A	A	A	A	A	C	C	C	C	H	H	H	H	H		L	L	L	L	J	J	J	J	J	J	L	L	L	L	
13	130	A	A	A	A	A	C	C	C		H	H	H	H	H		L	L	L	L	J	J	J	J	J	J	L	L	L	L	
15	150	A	A	A	A	A	C	C	C	C	H	H	H	H	H		L	L	L	L	J	J	J	J	J	J	L	L	L	L	
16	160	A	A	A	A		C	C	C		H	H	H	H	H		L	L	L	L	J	J	J	J	J	J	L	L	L	L	
18	180	A	A	A	A		C	C	C		H	H	H	H	H	H	L	L	L	L	J	J	J	J	J	J	L	L	L	L	
20	200	A	A	A	A		C	C	C		H	H	H	H	H	H	L	L	L	L	J	J	J	J	J	J	L	L	L	L	
22	220	A	A	A	A		C	C	C		H	H	H	H	H	H	L	L	L	L	J	J	J	J	J	J	L	L	L	L	
23	230										H	H	H	H	H																
24	240	A	A	A	A		C	C	C		H	H	H	H	H		L	L	L	L	J	J	J	J	J	J	L	L	L	L	
25	250										H	H	H	H	H																
27	270	A	A	A	A		C	C	C		H	H	H	H	H		L	L	L	L	J	J	J	J	J	J	L	L	L	L	
30	300	A	A	A	A		C	C	C	C	H	H	H	H	H		L	L	L	L	J	J	J	J	J	J	L	L	L	L	
33	330	A	A	A	A		C	C	C		H	H	H	H	H		L	L	L	L	J	J	J	J	J	J	L	L	L	L	
36	360	A	A	A	A		C	C	C		H	H	H	H	H		L	L	L	L	J	J	J	J	J	J	L	L	L	L	
38	380										H	H	H	H	H																
39	390	A	A	A	A		C	C	C		H	H	H	H	H		L	L	L	L	J	J	J	J	J	J	L	L	L	L	
40	400										H	H	H	H	H		L	L	L	L											
42	420										H	H	H	H	H																
43	430	A	A	A	A	A	C	C	C		H	H	H	H	H		L	L	L	L	J	J	J	J	J	J	L	L	L	L	
47	470	A	A	A	A		C	C	C		H	H	H	H	H		L	L	L	L	J	J	J	J	J	J	L	L	L	L	
50	500										H	H	H	H	H		L	L	L	L											
51	510	A	A	A	A		C	C	C		H	H	H	H	H		L	L	L	L	J	J	J	J	J	J	L	L	L	L	
53	530																L	L	L	L											
56	560	A	A	A	A		C	C	C		H	H	H	H	H		L	L	L	L	J	J	J	J	J	J	L	L	L	L	
60	600										H	H	H	H	H		L	L	L	L											
62	620	A	A	A	A	A	C	C	C		H	H	H	H	H		L	L	L	L	J	J	J	J	J	J	L	L	L	L	
68	680	A	A	A	A	A	C	C	C		H	H	H	H	H		L	L	L	L	J	J	J	J	J	J	L	L	L	L	
70	700																L	L	L	L											
75	750	A	A	A	A		C	C	C		H	H	H	H	H		L	L	L	L	J	J	J	J	J	J	L	L	L	L	
80	800										H	H	H	H	H		L	L	L	L											
82	820	A	A	A	A	A	C	C	C		H	H	H	H	H		L	L	L	L	J	J	J	J	J	J	L	L	L	L	
91	910	A	A	A	A		C	C	C		H	H	H	H	H		L	L	L	L	J	J	J	J	J	J	L	L	L	L	
100	101	A	A	A	A	A	C	C	C	C	H	H	H	H	H	H	L	L	L	L	J	J	J	J	J	J	R	R	R	R	
110	111						C	C	C		H	H	H	H	H	H	L	L	L	L											
120	121						C	C	C		H	H	H	H	H	H	L	L	L	L	J	J	J	J	J	J	L	L	L	L	
130	131						C	C	C		H	H	H	H	H		L	L	L	L	J	J	J	J	J	J	L	L	L	L	
150	151						C	C	C		H	H	H	H	H	H	L	L	L	L	J	J	J	J	J	J	L	L	L	L	
160	161										H	H	H	H	H		L	L	L	L	J	J	J	J	J	J	L	L	L	L	
180	181						C	C	C		H	H	H	H	H	H	L	L	L	L	J	J	J	J	J	J	L	L	L	L	
200	201						C	C	C		H	H	H	H	H		L	L	L	L	J	J	J	J	J	J	L	L	L	L	
220	221		A	A	A		C	C	C		H	H	H	H	H	H	L	L	L	L	J	J	J	J	J	J	L	L	L	L	
240	241		A	A	A		C	C	C		H	H	H	H	H	H	L	L	L	L	J	J	J	J	J	J	L	L	L	L	
250	251																L	L	L	L											
270	271		A	A	A		C	C	C		H	H	H	H	H	H	L	L	L	L	J	J	J	J	J	J	L	L	L	L	
300	301						C	C	C		H	H	H	H	H		L	L	L	L	J	J	J	J	J	J	L	L	L	L	
330	331		A	A	A		C	C	C		H	H	H	H	H	H	L	L	L	L	J	J	J	J	J	J	L	L	L	L	
360	361						C	C	C		H	H	H	H	H		L	L	L	L	J	J	J	J	J	J	L	L	L	L	
390	391						C	C	C		H	H	H	H	H	H	L	L	L	L	M	M	M	M	M	M	L	L	L	L	
430	431						C	C	C		H	H	H	H	H		L	L	L	L	M	M	M	M	M	M	L	L	L	L	
470	471						C	C	C		H	H	H	H	H	H	L	L	L	L	M	M	M	M	M	M	L	L	L	L	

MAX HEIGHT					
A	C	H	J	L	R
0.22	0.33	0.55	0.7	0.90	1.45

 NPO/COG

DIMENSION (MM)		NPO/COG																															
		GMC01		GMC02		GMC04				GMC10				GMC21				GMC31															
L		0.4 ± 0.02		0.6 ± 0.03		1.0 ± 0.05				1.6 ± 0.2				2.0 ± 0.3				3.2 ± 0.3															
W		0.2 ± 0.02		0.3 ± 0.03		0.5 ± 0.05				0.8 ± 0.2				1.25 ± 0.2				1.6 ± 0.2															
BW		0.07 ~ 0.14		0.15 ± 0.05		0.1 ~ 0.35				0.1 ~ 0.4				0.25 ~ 0.75				0.25 ~ 0.75															
RATED VOLTAGE		6.3	25	16	25	50	25	50	6.3	10	16	25	50	100	200	25	50	100	200	16	25	50	100	200	25	50	100	200					
CAP. RANGE																																	
500pF	501																																
510	511						C				H	H	H	H	H	H			L	L	L	L	M	M	M	M			L	L	L	L	
560	561						C				H	H	H	H	H	H			L	L	L	L	M	M	M	M	M		L	L	L	L	
620	621						C				H	H	H	H	H	H			L	L	L	L	M	M	M	M	M		L	L	L	L	
680	681						C				H	H	H	H	H	H			L	L	L	L	M	M	M	M	M	M		L	L	L	L
750	751						C				H	H	H	H	H	H			L	L	L	L	M	M	M	M	M		L	L	L	L	
820	821						C				H	H	H	H	H	H			L	L	L	L	M	M	M	M	M		L	L	L	L	
910	911						C				H	H	H	H	H	H			L	L	L	L	M	M	M	M	M		L	L	L	L	
1000	102						C				H	H	H	H	H	H			L	L	L	L	M	M	M	M	M		L	L	L	L	
1100	112										H	H	H	H	H				L	L	L	L	M	M	M	M	M						
1200	122										H	H	H	H	H				M	M	M	M	M	M	M	M	M	M	L	L	L	L	
1300	132										H	H	H	H	H				M	M	M	M	M	M	M	M	M						
1500	152										H	H	H	H	H				M	M	M	M	M	M	M	M	M	M	L	L	L	L	
1600	162										H	H	H	H					M	M	M	M											
1800	182										H	H	H	H					M	M	M	M	M	M	M	M	M	M	L	L	L	L	
2000	202										H	H	H	H					M	M	M	M	M	M	M	M	M						
2200	222										H	H	H	H					M	M	M	M	M	R	R	R	R	R	L	L	L	L	
2400	242																		M	M	M	M		R	R	R	R	R	L	L	L	L	
2700	272										H	H	H	H					M	M	M	M		R	R	R	R	R	L	L	L	L	
3000	302																		M	M	M	M		R	R	R	R	R	M	M	M	M	
3300	332										H	H	H	H					M	M	M	M		R	R	R	R	R	M	M	M	M	
3600	362																						R	R	R	R	R						
3900	392																		M	M	M	M		R	R	R	R	R	M	M	M	M	
4300	432																						R	R	R	R	R						
4700	472										I	I	I	I	I				M	M	M	M		R	R	R	R	R	M	M	M	M	
5600	562										I	I	I	I	I				M	M	M	M		R	R	R	R	R	M	M	M	M	
6200	622																		M	M	M	M		R	R	R							
6800	682										I	I	I	I	I				M	M	M	M		R	R	R	R		O	O	O		
7500	752																		M	M	M	M		R	R	R							
8200	822																		M	M	M	M		R	R	R	R		R	R	R		
9100	912																		M	M	M	M		R	R	R							
0.01uF	103										I	I	I	I					M	M	M	M		R	R	R	R		R	R	R	R	
0.012	123																		M					R	R	R			U	U	U		
0.015	153																		M					R	R	R			U	U	U		
0.018	183																						R	R	R			U	U	U			
0.02	203																						R	R	R								
0.022	223																						R	R	R	R		U	U	U			
0.027	273																						R	R	R			U	U	U			
0.03	303																						R	R									
0.033	333																						R	R	R	R		U	U	U			
0.039	393																											U	U	U			
0.047	473																						R	R	R			U	U	U			
0.056	563																											U	U	U			
0.068	683																											U	U	U			
0.082	823																											U	U	U			
0.1	104																											U	U	U			
0.12	124																											U	U	U			

MAX HEIGHT							
C	H	I	L	M	Q	R	U
0.33	0.55	0.65	0.90	0.95	1.40	1.45	1.90



DIELECTRIC		NPO/COG																			
DIMENSION (MM)		GMC32			GMC40			GMC43			GMC45			GMC55			GMC57				
L		3.2 ± 0.3			4.57 ± 0.25			4.5 ± 0.35			4.5 ± 0.35			5.7 ± 0.4			5.7 ± 0.4				
W		2.5 ± 0.3			2.03 ± 0.25			3.2 ± 0.3			6.3 ± 0.4			5.0 ± 0.4			6.3 ± 0.4				
BW		0.25 ~ 0.75			0.25 ~ 0.75			0.25 ~ 0.75			0.40 ~ 1.10			0.50 ~ 1.20			0.50 ~ 1.20				
RATED VOLTAGE		16	25	50	100	200	50	100	200	50	100	200	50	100	200	50	100	200	50	100	200
CAP. RANGE																					
10pF	100	R	R	R	R	R	R	R	R	V	V	V	V	V	V	V	V	V	V	V	V
11	110	R	R	R	R	R	R	R	R	V	V	V	V	V	V	V	V	V	V	V	V
12	120	R	R	R	R	R	R	R	R	V	V	V	V	V	V	V	V	V	V	V	V
13	130	R	R	R	R	R	R	R	R	V	V	V	V	V	V	V	V	V	V	V	V
15	150	R	R	R	R	R	R	R	R	V	V	V	V	V	V	V	V	V	V	V	V
16	160	R	R	R	R	R	R	R	R	V	V	V	V	V	V	V	V	V	V	V	V
18	180	R	R	R	R	R	R	R	R	V	V	V	V	V	V	V	V	V	V	V	V
20	200	R	R	R	R	R	R	R	R	V	V	V	V	V	V	V	V	V	V	V	V
22	220	R	R	R	R	R	R	R	R	V	V	V	V	V	V	V	V	V	V	V	V
24	240	R	R	R	R	R	R	R	R	V	V	V	V	V	V	V	V	V	V	V	V
27	270	R	R	R	R	R	R	R	R	V	V	V	V	V	V	V	V	V	V	V	V
30	300	R	R	R	R	R	R	R	R	V	V	V	V	V	V	V	V	V	V	V	V
33	330	R	R	R	R	R	R	R	R	V	V	V	V	V	V	V	V	V	V	V	V
36	360	R	R	R	R	R	R	R	R	V	V	V	V	V	V	V	V	V	V	V	V
39	390	R	R	R	R	R	R	R	R	V	V	V	V	V	V	V	V	V	V	V	V
43	430	R	R	R	R	R	R	R	R	V	V	V	V	V	V	V	V	V	V	V	V
47	470	R	R	R	R	R	R	R	R	V	V	V	V	V	V	V	V	V	V	V	V
51	510	R	R	R	R	R	R	R	R	V	V	V	V	V	V	V	V	V	V	V	V
56	560	R	R	R	R	R	R	R	R	V	V	V	V	V	V	V	V	V	V	V	V
62	620	R	R	R	R	R	R	R	R	V	V	V	V	V	V	V	V	V	V	V	V
68	680	R	R	R	R	R	R	R	R	V	V	V	V	V	V	V	V	V	V	V	V
75	750	R	R	R	R	R	R	R	R	V	V	V	V	V	V	V	V	V	V	V	V
82	820	R	R	R	R	R	R	R	R	V	V	V	V	V	V	V	V	V	V	V	V
91	910	R	R	R	R	R	R	R	R	V	V	V	V	V	V	V	V	V	V	V	V
100	101	R	R	R	R	R	R	R	R	V	V	V	V	V	V	V	V	V	V	V	V
120	121	R	R	R	R	R	R	R	R	V	V	V	V	V	V	V	V	V	V	V	V
130	131	R	R	R	R	R	R	R	R	V	V	V	V	V	V	V	V	V	V	V	V
150	151	R	R	R	R	R	R	R	R	V	V	V	V	V	V	V	V	V	V	V	V
160	161	R	R	R	R	R	R	R	R	V	V	V	V	V	V	V	V	V	V	V	V
180	181	R	R	R	R	R	R	R	R	V	V	V	V	V	V	V	V	V	V	V	V
200	201	R	R	R	R	R	R	R	R	V	V	V	V	V	V	V	V	V	V	V	V
220	221	R	R	R	R	R	R	R	R	V	V	V	V	V	V	V	V	V	V	V	V
240	241	R	R	R	R	R	V	V	V	V	V	V	V	V	V	V	V	V	V	V	V
270	271	R	R	R	R	R	V	V	V	V	V	V	V	V	V	V	V	V	V	V	V
300	301	R	R	R	R	R	V	V	V	V	V	V	V	V	V	V	V	V	V	V	V
330	331	R	R	R	R	R	V	V	V	V	V	V	V	V	V	V	V	V	V	V	V
360	361	R	R	R	R	R	V	V	V	V	V	V	V	V	V	V	V	V	V	V	V
390	391	R	R	R	R	R	V	V	V	V	V	V	V	V	V	V	V	V	V	V	V
430	431	R	R	R	R	R	V	V	V	V	V	V	V	V	V	V	V	V	V	V	V
470	471	R	R	R	R	R	V	V	V	V	V	V	V	V	V	V	V	V	V	V	V

MAX HEIGHT	
R	V
1.45	2.20

NPO/COG

DIELECTRIC		NPO/COG																			
DIMENSION (MM)		GMC32					GMC40			GMC43			GMC45			GMC55			GMC57		
L	W	3.2 ± 0.3					4.57 ± 0.25			4.5 ± 0.35			4.5 ± 0.35			5.7 ± 0.4			5.7 ± 0.4		
W	BW	2.5 ± 0.3					2.03 ± 0.25			3.2 ± 0.3			6.3 ± 0.4			5.0 ± 0.4			6.3 ± 0.4		
BW		0.25 ~ 0.75					0.25 ~ 0.75			0.25 ~ 0.75			0.40 ~ 1.10			0.50 ~ 1.20			0.50 ~ 1.20		
RATED VOLTAGE		16	25	50	100	200	50	100	200	50	100	200	50	100	200	50	100	200	50	100	200
CAP. RANGE																					
510pF	511	R	R	R	R	R	V	V	V	V	V	V	V	V	V	V	V	V	V	V	V
560	561	R	R	R	R	R	V	V	V	V	V	V	V	V	V	V	V	V	V	V	V
620	621						V	V	V	V	V	V	V	V	V	V	V	V	V	V	V
680	681	R	R	R	R	R	V	V	V	V	V	V	V	V	V	V	V	V	V	V	V
750	751	R	R	R	R	R	V	V	V	V	V	V	V	V	V	V	V	V	V	V	V
820	821	R	R	R	R	R	V	V	V	V	V	V	V	V	V	V	V	V	V	V	V
910	911	R	R	R	R	R	V	V	V	V	V	V	V	V	V	V	V	V	V	V	V
1000	102	R	R	R	R	R	V	V	V	V	V	V	V	V	V	V	V	V	V	V	V
1100	112						V	V	V	V	V	V	V	V	V	V	V	V	V	V	V
1200	122	R	R	R	R	R	V	V	V	V	V	V	V	V	V	V	V	V	V	V	V
1500	152	R	R	R	R	R	V	V	V	V	V	V	V	V	V	V	V	V	V	V	V
1800	182	R	R	R	R	R	V	V	V	V	V	V	V	V	V	V	V	V	V	V	V
2000	202						V	V	V	V	V	V	V	V	V	V	V	V	V	V	V
2200	222	R	R	R	R	R	V	V	V	V	V	V	V	V	V	V	V	V	V	V	V
2400	242	R	R	R	R	R	V	V	V	V	V	V	V	V	V	V	V	V	V	V	V
2700	272	R	R	R	R	R	V	V	V	V	V	V	V	V	V	V	V	V	V	V	V
3000	302						V	V	V	V	V	V	V	V	V	V	V	V	V	V	V
3300	332	R	R	R	R	R	V	V	V	V	V	V	V	V	V	V	V	V	V	V	V
3900	392	R	R	R	R	R	V	V	V	V	V	V	V	V	V	V	V	V	V	V	V
4700	472	R	R	R	R	R	V	V	V	V	V	V	V	V	V	V	V	V	V	V	V
5600	562	R	R	R	R	R	V	V	V	V	V	V	V	V	V	V	V	V	V	V	V
6800	682	R	R	R	R	R	V	V	V	V	V	V	V	V	V	V	V	V	V	V	V
7500	752	R	R	R	R	R	V	V	V	V	V	V	V	V	V	V	V	V	V	V	V
8200	822	R	R	R	R	R	V	V		V	V	V	V	V	V	V	V	V	V	V	V
.01uF	103	R	R	R	R	R	V	V		V	V	V	V	V	V	V	V	V	V	V	V
0.012	123	P	P	P	P	P	V	V		V	V	V	V	V	V	V	V	V	V	V	V
0.015	153	P	P	P	P	P	V			V	V	V	V	V	V	V	V	V	V	V	V
0.018	183	V	V	V	V	V	V			V	V	V	V	V	V	V	V	V	V	V	V
0.022	223	V	V	V	V	V				V	V	V	V	V	V	V	V	V	V	V	V
0.027	273	V	V	V	V	V				V	V	V	V	V	V	V	V	V	V	V	V
0.033	333	V	V	V	V	V				V	V	V	V			V	V			V	V
0.039	393	V	V	V	V	V				Y	Y	Y	V	V		V	V			V	V
0.047	473	V	V	V	V	V				Y	Y	Y	V	V		V	V			V	V
0.056	563	V	V	V	V					Y	Y	Y	V	V		V	V			V	V
0.068	683	V	V	V	V					Y	Y	Y	V	V		V	V			V	V
0.082	823	V	V	V	V					Y	Y	Y	V			Y	Y			V	V
0.1	104	V	V	V	V					Y	Y	Y	V			Y	Y			V	V
0.12	124									Y	Y		V			V	V			Y	Y
0.15	154	W	W	W						Y	Y		V			V	V				
0.18	184									Y			V			V	V				
0.22	224	W	W							A2						V	V				
0.27	274															V	V				
0.33	334															V	V				
0.47	474															V					
1	105																				
2.2	225																				
4.7	475																				

MAX HEIGHT					
R	P	V	W	Y	A2
1.45	1.35	2.2	2.3	2.8	3.5



DIELECTRIC		X7R																																															
DIMENSION (MM)		GMC01			GMC02			GMC04			GMC10						GMC21						GMC31																										
L	0.4 ± 0.02	0.6 ± 0.03			1.0 ± 0.05			1.6 ± 0.2						2.0 ± 0.3						3.2 ± 0.3																													
W	0.2 ± 0.02	0.3 ± 0.03			0.5 ± 0.05			0.8 ± 0.2						1.25 ± 0.2						1.6 ± 0.2																													
BW	0.07 ~ 0.14	0.15 ± 0.05			0.1 ~ 0.35			0.1 ~ 0.4						0.25 ~ 0.75						0.25 ~ 0.75																													
RATED VOLTAGE	6.3	10	16	6.3	10	16	25	50	6.3	10	16	25	50	100	4	6.3	10	16	25	35	50	100	200	6.3	10	16	25	35	50	100	200	6.3	10	16	25	35	50	100	200										
CAP. RANGE																																																	
56pF	560	A	A																																														
68	680	A	A																																														
82	820	A	A																																														
100	101	A	A	A	C	C	C	C	C	H	H	H	H	H		L	L	L	L	L	L	L	L	M	M	M	M	M	M	M	M	M	M	R	R	R	R	R	R	R									
120	121	A	A		C	C	C	C	C	H	H	H	H	H		L	L	L	L	L	L	L	L	M	M	M	M	M	M	M	M	M	M	M	M	M	M	M	M	M									
150	151	A	A	A	C	C	C	C	C	H	H	H	H	H		L	L	L	L	L	L	L	L	M	M	M	M	M	M	M	M	M	M	M	M	M	M	M	M	M	M								
180	181	A	A		C	C	C	C	C	H	H	H	H	H		L	L	L	L	L	L	L	L	M	M	M	M	M	M	M	M	M	M	M	M	M	M	M	M	M	M								
200	201				C	C	C	C	C	H	H	H	H	H	H	L	L	L	L	L	L	L	L	M	M	M	M	M	M	M	M	M	M	M	M	M	M	M	M	M	M								
220	221	A	A	A	C	C	C	C	C	H	H	H	H	H	H	L	L	L	L	L	L	L	L	M	M	M	M	M	M	M	M	M	M	M	M	M	M	M	M	M	M	M							
240	241									H	H	H	H	H		L	L	L	L	L	L	L	L	M	M	M	M	M	M	M	M	M	M	M	M	M	M	M	M	M	M	M							
270	271	A	A		C	C	C	C	C	H	H	H	H	H	H	L	L	L	L	L	L	L	L	M	M	M	M	M	M	M	M	M	M	M	M	M	M	M	M	M	M	M							
300	301									H	H	H	H	H	H	L	L	L	L	L	L	L	L	M	M	M	M	M	M	M	M	M	M	M	M	M	M	M	M	M	M	M	M						
330	331	A	A		C	C	C	C	C	H	H	H	H	H	H	L	L	L	L	L	L	L	L	M	M	M	M	M	M	M	M	M	M	M	M	M	M	M	M	M	M	M	M						
360	361									H	H	H	H	H		L	L	L	L	L	L	L	L	M	M	M	M	M	M	M	M	M	M	M	M	M	M	M	M	M	M	M	M	M					
390	391	A	A		C	C	C	C	C	H	H	H	H	H	H	L	L	L	L	L	L	L	L	M	M	M	M	M	M	M	M	M	M	M	M	M	M	M	M	M	M	M	M	M					
430	431															L	L	L	L	L	L	L	L	M	M	M	M	M	M	M	M	M	M	M	M	M	M	M	M	M	M	M	M	M					
470	471	A	A	A	C	C	C	C	C	H	H	H	H	H	H	L	L	L	L	L	L	L	L	M	M	M	M	M	M	M	M	M	M	M	M	M	M	M	M	M	M	M	M	M					
510	511									H	H	H	H	H		L	L	L	L	L	L	L	L	M	M	M	M	M	M	M	M	M	M	M	M	M	M	M	M	M	M	M	M	M					
560	561	A	A		C	C	C	C	C	H	H	H	H	H	H	L	L	L	L	L	L	L	L	M	M	M	M	M	M	M	M	M	M	M	M	M	M	M	M	M	M	M	M	M	M				
620	621									H	H	H	H	H	H	L	L	L	L	L	L	L	L	M	M	M	M	M	M	M	M	M	M	M	M	M	M	M	M	M	M	M	M	M	M	M			
680	681	A	A	A	C	C	C	C	C	H	H	H	H	H	H	L	L	L	L	L	L	L	L	M	M	M	M	M	M	M	M	M	M	M	M	M	M	M	M	M	M	M	M	M	M	M			
750	751									H	H	H	H	H	H	L	L	L	L	L	L	L	L	M	M	M	M	M	M	M	M	M	M	M	M	M	M	M	M	M	M	M	M	M	M	M			
820	821	A	A		C	C	C	C	C	H	H	H	H	H	H	L	L	L	L	L	L	L	L	M	M	M	M	M	M	M	M	M	M	M	M	M	M	M	M	M	M	M	M	M	M	M	M		
910	911															L	L	L	L	L	L	L	L	M	M	M	M	M	M	M	M	M	M	M	M	M	M	M	M	M	M	M	M	M	M	M	M		
1000	102	A	A		C	C	C	C	C	H	H	H	H	H	H	L	L	L	L	L	L	L	L	M	M	M	M	M	M	M	M	M	M	M	M	M	M	M	M	M	M	M	M	M	M	M	M		
1200	122	A	A		C	C	C	C	C	H	H	H	H	H	H	L	L	L	L	L	L	L	L	M	M	M	M	M	M	M	M	M	M	M	M	M	M	M	M	M	M	M	M	M	M	M	M	M	
1500	152	A	A		C	C	C	C	C	H	H	H	H	H	H	L	L	L	L	L	L	L	L	M	M	M	M	M	M	M	M	M	M	M	M	M	M	M	M	M	M	M	M	M	M	M	M	M	
1800	182				C	C	C	C	C	H	H	H	H	H	H	L	L	L	L	L	L	L	L	M	M	M	M	M	M	M	M	M	M	M	M	M	M	M	M	M	M	M	M	M	M	M	M	M	
2000	202									H	H	H	H	H	H	L	L	L	L	L	L	L	L	M	M	M	M	M	M	M	M	M	M	M	M	M	M	M	M	M	M	M	M	M	M	M	M	M	
2200	222	A	A	A	C	C	C	C	C	H	H	H	H	H	H	L	L	L	L	L	L	L	L	M	M	M	M	M	M	M	M	M	M	M	M	M	M	M	M	M	M	M	M	M	M	M	M	M	
2400	242															L	L	L	L	L	L	L	L	M	M	M	M	M	M	M	M	M	M	M	M	M	M	M	M	M	M	M	M	M	M	M	M	M	
2700	272				C	C	C	C	C	H	H	H	H	H	H	L	L	L	L	L	L	L	L	M	M	M	M	M	M	M	M	M	M	M	M	M	M	M	M	M	M	M	M	M	M	M	M	M	
3000	302																								M	M	M	M	M	M	M	M	M	M	M	M	M	M	M	M	M	M	M	M	M	M	M	M	
3300	332				C	C	C	C	C	H	H	H	H	H	H	L	L	L	L	L	L	L	L	M	M	M	M	M	M	M	M	M	M	M	M	M	M	M	M	M	M	M	M	M	M	M	M	M	M
3600	362																							M	M	M	M	M	M	M	M	M	M	M	M	M	M	M	M	M	M	M	M	M	M	M	M	M	
3900	392				C	C	C	C	C	H	H	H	H	H	H	L	L	L	L	L	L	L	L	M	M	M	M	M	M	M	M	M	M	M	M	M	M	M	M	M	M	M	M	M	M	M	M	M	

MAX HEIGHT					
A	C	H	L	M	R
0.22	0.33	0.55	0.90	0.95	1.45



DIELECTRIC		X7R																																											
DIMENSION (MM)		GMC32								GMC40				GMC43								GMC45								GMC55								GMC57							
L		3.2 ± 0.3								4.57 ± 0.25				4.5 ± 0.35								4.5 ± 0.35								5.7 ± 0.4								5.7 ± 0.4							
W		2.5 ± 0.3								2.03 ± 0.25				3.2 ± 0.3								6.3 ± 0.4								5.0 ± 0.4								6.3 ± 0.4							
BW		0.25 ~ 0.75								0.25 ~ 0.75				0.25 ~ 0.75								0.40 ~ 1.10								0.50 ~ 1.20								0.50 ~ 1.20							
RATED VOLTAGE		6.3	10	16	25	35	50	100	200	50	100	200	10	16	25	50	100	200	16	25	50	100	200	16	25	50	100	200	16	25	50	100	200	16	25	50	100	200							
CAP. RANGE																																													
1000pF	102	O	O	O	O	O	O	O	O	R	R	R	R	R	R	R	R	R	R	R	R	R	R	R	R	R	R	R	V	V	V	V	V	V	V	V	V	V							
1200	122	O	O	O	O	O	O	O	O	R	R	R	R	R	R	R	R	R	R	R	R	R	R	R	R	R	R	V	V	V	V	V	V	V	V	V	V								
1500	152	O	O	O	O	O	O	O	O	R	R	R	R	R	R	R	R	R	R	R	R	R	R	R	R	R	R	V	V	V	V	V	V	V	V	V	V								
1800	182	O	O	O	O	O	O	O	O	R	R	R	R	R	R	R	R	R	R	R	R	R	R	R	R	R	R	V	V	V	V	V	V	V	V	V	V								
2200	222	O	O	O	O	O	O	O	O	R	R	R	R	R	R	R	R	R	R	R	R	R	R	R	R	R	R	V	V	V	V	V	V	V	V	V	V								
2400	242	O	O	O	O	O	O	O	O	R	R	R	R	R	R	R	R	R	R	R	R	R	R	R	R	R	R	V	V	V	V	V	V	V	V	V	V								
2700	272	O	O	O	O	O	O	O	O	R	R	R	R	R	R	R	R	R	R	R	R	R	R	R	R	R	R	V	V	V	V	V	V	V	V	V	V								
3000	302	O	O	O	O	O	O	O	O	R	R	R	R	R	R	R	R	R	R	R	R	R	R	R	R	R	R	V	V	V	V	V	V	V	V	V	V								
3300	332	O	O	O	O	O	O	O	O	R	R	R	R	R	R	R	R	R	R	R	R	R	R	R	R	R	R	V	V	V	V	V	V	V	V	V	V								
3600	362	O	O	O	O	O	O	O	O	R	R	R	R	R	R	R	R	R	R	R	R	R	R	R	R	R	R	V	V	V	V	V	V	V	V	V	V								
3900	392	O	O	O	O	O	O	O	O	R	R	R	R	R	R	R	R	R	R	R	R	R	R	R	R	R	R	V	V	V	V	V	V	V	V	V	V								
4300	432	O	O	O	O	O	O	O	O	R	R	R	R	R	R	R	R	R	R	R	R	R	R	R	R	R	R	V	V	V	V	V	V	V	V	V	V								

MAX HEIGHT		
O	R	V
1.10	1.45	2.20



DIELECTRIC		X7R																																										
DIMENSION (MM)		GMC32				GMC40				GMC43				GMC45				GMC55				GMC57																						
L	3.2 ± 0.3	3.2 ± 0.3				4.57 ± 0.25				4.5 ± 0.35				4.5 ± 0.35				5.7 ± 0.4				5.7 ± 0.4																						
W	2.5 ± 0.3	2.5 ± 0.3				2.03 ± 0.25				3.2 ± 0.3				6.3 ± 0.4				5.0 ± 0.4				6.3 ± 0.4																						
BW	0.25 - 0.75	0.25 - 0.75				0.25 - 0.75				0.25 - 0.75				0.40 - 1.10				0.50 - 1.20				0.50 - 1.20																						
RATED VOLTAGE	6.3 10 16 25 35 50 63 100 200	6.3 10 16 25 35 50 63 100 200	10 16 25 50 100 200	10 16 25 50 100 200	16 25 50 100 200	16 25 50 100 200	25 50 100 200	25 50 100 200	25 50 100 200	25 50 100 200	25 50 100 200	25 50 100 200	25 50 100 200	25 50 100 200	25 50 100 200	25 50 100 200	25 50 100 200	25 50 100 200	25 50 100 200	25 50 100 200	25 50 100 200	25 50 100 200	25 50 100 200	25 50 100 200	25 50 100 200	25 50 100 200	25 50 100 200	25 50 100 200																
CAP. RANGE	4700pF 5600 6800 8200 0.01uF 0.012 0.015 0.018 0.022 0.027 0.033 0.039 0.047 0.056 0.068 0.082 0.1 0.12 0.15 0.18 0.22 0.27 0.33 0.39 0.47 0.56 0.68 0.82 1 1.5 2.2 3.3 4.7 6.8 10 15 22 33 47 100	472 562 682 822 103 123 153 183 223 273 333 393 473 563 683 823 104 124 154 184 224 274 334 394 474 564 684 824 105 155 225 335 475 685 106 156 226 336 476 107	O O O O O O O O O O O R R R R R V V V V V V V V V V V V V V V V V V V	O O O O O O O O O O O V V V V R R R R R R R V V V V V V V V V V V V V V V V V	O O O O O O O O O O O V V V V R R R R R R R V V V V V V V V V V V V V V V V V	O O O O O O O O O O O V V V V R R R R R R R V V V V V V V V V V V V V V V V V	O O O O O O O O O O O V V V V R R R R R R R V V V V V V V V V V V V V V V V V	O O O O O O O O O O O V V V V R R R R R R R V V V V V V V V V V V V V V V V V	O O O O O O O O O O O V V V V R R R R R R R V V V V V V V V V V V V V V V V V	O O O O O O O O O O O V V V V R R R R R R R V V V V V V V V V V V V V V V V V	O O O O O O O O O O O V V V V R R R R R R R V V V V V V V V V V V V V V V V V	O O O O O O O O O O O V V V V R R R R R R R V V V V V V V V V V V V V V V V V	O O O O O O O O O O O V V V V R R R R R R R V V V V V V V V V V V V V V V V V	O O O O O O O O O O O V V V V R R R R R R R V V V V V V V V V V V V V V V V V	O O O O O O O O O O O V V V V R R R R R R R V V V V V V V V V V V V V V V V V	O O O O O O O O O O O V V V V R R R R R R R V V V V V V V V V V V V V V V V V	O O O O O O O O O O O V V V V R R R R R R R V V V V V V V V V V V V V V V V V	O O O O O O O O O O O V V V V R R R R R R R V V V V V V V V V V V V V V V V V	V V	O O O O O O O O O O O O O A1 A1 V R R R R R R V V V V V V V V V V V V V V V V	O O O O O O O O O O O Y Y A1 A1 V R R R R R R V V V V V V V V V V V V V V V V	O O O O O O O O O O O Y Y A1 A1 V R R R R R R V V V V V V V V V V V V V V V V	O O O O O O O O O O O R A1 A1 V R R R R R R V V V V V V V V V V V V V V V V	O O O O O O O O O O O T Y A1 A1 V R R R R R R V V V V V V V V V V V V V V V V	O O O O O O O O O O O T A1 A1 V R R R R R R V V V V V V V V V V V V V V V V	O O O O O O O O O O O R R R Z Z Z A1 V R R R R R R V V V V V V V V V V V V V V V V	O O O O O O O O O O O V A1 V R R R R R R V V V V V V V V V V V V V V V V	R R R R R R R R R Y Y A1 V R R R R R R V V V V V V V V V V V V V V V V	O O O O O O O O O T Y A1 V R R R R R R V V V V V V V V V V V V V V V V	O O O O O O O O O V A1 V R R R R R R V V V V V V V V V V V V V V V V	T T T T T T T Y V V V V V V Y R R R R V X X X X X V V V V V V V	Z Z Z Z Z Z Z Z V V V V V V Y V V V V V V Y Y Y Y Y Y	Z Z Z Z Z Z Z Z V V V V V V Y V V V V V V Y V V V V V Y Y Y Y Y	Z Z Z Z Z Z Z Z V V V V V V Y V V V V V V V V V V V V V V V V	Z Z Z Z Z Z Z Z V V V V V V Y V V V V V V V V V V V V V V V V	Z Z Z Z Z Z Y V V V V V Y V V V V V V Y Y Y Y Y Y	Y Y Y A1 A1 A1 V V V V V Y A1 A1 V V V V V	Y Y Y Y V V Y Y Y V V V V V V Y Y Y	Y Y V V V V V V X X					

MAX HEIGHT							
O	R	T	V	X	Y	Z	A1
1.10	1.45	1.80	2.2	2.5	2.8	2.9	3.1



DIELECTRIC		X7S																																															
DIMENSION (MM)		GMC02						GMC04						GMC10						GMC21						GMC31						GMC32						GMC55											
L(L1)		0.6 ± 0.03						1.0 ± 0.05						1.6 ± 0.2						2.0 ± 0.3						3.2 ± 0.3						3.2 ± 0.3						5.7 ± 0.4											
W		0.3 ± 0.03						0.5 ± 0.05						0.8 ± 0.2						1.25 ± 0.2						1.6 ± 0.2						2.5 ± 0.3						6.3 ± 0.4											
BW(L2/LW)		0.15 ± 0.05						0.1 - 0.35						0.1 - 0.4						0.25 - 0.75						0.25 - 0.75						0.25 - 0.75						0.50 - 1.2											
RATED VOLTAGE		4	6.3	10	16	4/6.3	10	16	25	50	100	4/6.3	10	16	25	35	50	100	4	6.3	10	16	25	35	50	100	4	6	10	16	25	35	50	100	4	6.3	10	16	25	50	63	100	4	6.3	10	16	25	50	100
CAP. RANGE																																																	
1000pF	102																																																
1500	152																																																
2200	222																																																
3300	332																																																
4700	472																																																
6800	682																																																
.01uF	103																																																
0.022	223	C	C	C																																													
0.033	333																																																
0.039	393																																																
0.047	473	C	C	C																																													
0.056	563																																																
0.068	683																																																
0.082	823																																																
0.1	104	C	C	C	C																																												
0.15	154																																																
0.22	224	D	D																																														
0.33	334																																																
0.47	474																																																
0.56	564																																																
0.68	684																																																
0.82	824																																																
1	105																																																
1.5	155																																																
2.2	225	J	J																																														
3.3	335																																																
4.7	475																																																
6.8	685																																																
10	106																																																
15	156																																																
22	226																																																
33	336																																																
47	476																																																
100	107																																																

MAX HEIGHT															
C	D	H	I	J	L	M	N	P	R	T	U	V	X	Y	Z
0.33	0.35	0.55	0.65	0.7	0.90	0.95	1.00	1.35	1.45	1.80	1.90	2.2	2.5	2.8	2.9

X6S

DIELECTRIC		X6S																																		
DIMENSION (MM)		GMC02						GMC04						GMC10						GMC21						GMC31										
L		0.6 ± 0.03						1.0 ± 0.05						1.6 ± 0.2						2.0 ± 0.3						3.2 ± 0.3										
W		0.3 ± 0.03						0.5 ± 0.05						0.8 ± 0.2						1.25 ± 0.2						1.6 ± 0.2										
BW		0.15 ± 0.05						0.1 ~ 0.35						0.1 ~ 0.4						0.25 ~ 0.75						0.25 ~ 0.75										
RATED VOLTAGE		4	6.3	10	16	25	35	4	6.3	10	16	25	35	50	4	6.3	10	16	25	35	50	4	6.3	10	16	25	35	50	4	6.3	10	16	25	35	50	100
CAP. RANGE																																				
2200pF	222	C	C	C	C	C																														
4700	472	C	C	C	C	C																														
.01uf	103	C	C	C	C	C	H	H	H	H	H	H	H																							
0.012	123	C	C				H	H	H	H	H	H	H																							
0.015	153	C	C				H	H	H	H	H	H	H																							
0.018	183	C	C				H	H	H	H	H	H	H																							
0.022	223	C	C	C	C	C	H	H	H	H	H	H	H																							
0.027	273	C	C	C	C		H	H	H	H	H	H																								
0.033	333	C	C	C	C		H	H	H	H	H	H	H																							
0.039	393	C	C																																	
0.047	473	C	C	C	C	C	H	H	H	H	H	H	H																							
0.056	563	C	C				H	H	H	H	H	H	J	J																						
0.068	683	C	C	C	C		H	H	H	H	H	H	J	J																						
0.082	823	C	C				H	H	H	H	H	H	J	J																						
0.1	104	C	C	C	C		H	H	H	H	H	H	J	J																						
0.12	124						H	H																												
0.15	154						H	H	H	H	H				M	M	M	M	M	M	M															
0.18	184						H	H							M	M	M	M	M																	
0.22	224	C	C				H	H	H	H	H	H			M	M	M	M	M	M	M															
0.27	274						H	H							M	M	M	M																		
0.33	334						H	H	H	H					M	M	M	M	M	M	M															
0.39	394						H	H							M	M	M	M																		
0.47	474	E	E	E	E		H	H	H	H					M	M	M	M	M	M	M	R	R	R	R	R	R	R	R	R	R	R	R			
0.56	564						H	H							M	M	M	M				R	R	R	R											
0.68	684						H	H	H	H					M	M	M	M	M	M	M	R	R	R	R	R	R	R	R	R	R	R	R			
0.82	824						H	H							M	M	M	M				R	R	R	R											
1	105	E	E	E	E		J	J	J	J	J	J			M	M	M	M	M	M	M	R	R	R	R	R	R	R	R	T	T	T	T	T		
1.5	155														N	N	N	N				R	R	R	R	R	R	R	R	U	U	U	U	U		
2.2	225						J	J	J	J	J				N	N	N	N				R	R	R	R	R	R	R	U	U	U	U	U	U		
2.7	275																																			
3.3	335														N	N	N	N				R	R	R	R	R	R	R	U	U	U	U	U	U		
3.9	395																																			
4.7	475						I	I							N	N	N	N	N			R	R	R	R	R	R	R	U	U	U	U	U	U		
6.8	685														N	N	N					R	R	R	R			U	U	U	U	U	U			
10	106						J	J							N	N	N	N				R	R	R	R	R	R	U	U	U	U	U	U	U		
15	156																					R	R	R	R			U	U	U	U					
22	226						K								N	N	N					R	R	R	R			U	U	U	U	U				
33	336																					R					U	U	U							
47	476														N							R	R				U	U	U							
68	686																										U									
100	107																						R				U	U								
150	157																										U									
220	227																										U									

MAX HEIGHT

C	E	H	I	J	K	M	N	R	T	U
0.33	0.39	0.55	0.65	0.7	0.8	0.95	1.00	1.45	1.80	1.90



		X6S															
DIMENSION (MM)		GMC32								GMC43							
L(L1)		3.2 ± 0.30								4.5 ± 0.35							
W		2.5 ± 0.30								3.2 ± 0.30							
BW(L2/LW)		0.75 ± 0.25								0.25 ~ 0.75							
RATED VOLTAGE		2.5	4	6.3	10	16	25	35	50	4	6.3	10	16	25	35	50	
CAP. RANGE																	
3.3uF	335							Z	Z	Z							
4.7	475							Z	Z	Z							
6.8	685							Z	Z	Z							
10	106				Z	Z	Z	Z	Z								
22	226				Y	Y	Y										
33	336																
47	476				Y	Y	Y										
68	686																
100	107	Z	Z	Z	Z					A1	A1						
150	157	Z	Z														
220	227	Z	Z	Z													
330	337	Z	Z														

MAX HEIGHT		
Y	Z	A1
2.8	2.9	3.1

DIELECTRIC DIMENSION (MM)		X5R																																
		GMC31								GMC32								GMC43								GMC55								
L		3.2 ± 0.3								3.2 ± 0.3								4.5 ± 0.35								5.7 ± 0.4								
W		1.6 ± 0.2								2.5 ± 0.3								3.2 ± 0.3								5.0 ± 0.4								
BW		0.25 ~ 0.75								0.25 ~ 0.75								0.25 ~ 0.75								0.50 ~ 1.2								
RATED VOLTAGE		4	6.3	10	16	25	35	50	100	4	6.3	10	16	25	35	50	63	100	6.3	10	16	25	35	50	100	6.3	10	16	25	50	100			
CAP. RANGE																																		
.1uF	104	M	M	M	M	M	M	M	M	V	V	V	V	V	V	V	V	V																
0.12	124	M	M	M	M	M	M	M	M	O	O	O	O	O	O	O	O	O																
0.15	154	P	P	P	P	P	P	P	T	O	O	O	O	O	O	O	O	O																
0.18	184	P	P	P	P	P	P	P	T	O	O	O	O	O	O	O	O	O																
0.22	224	Q	Q	Q	Q	Q	Q	Q	T	O	O	O	O	O	O	O	O	O																
0.27	274	Q	Q	Q	Q	Q	Q	Q	T	O	O	O	O	O	O	O	O	O																
0.33	334	Q	Q	Q	Q	Q	Q	Q	T	O	O	O	O	O	O	O	O	O																
0.39	394	U	U	U	U	U	U	U	U	O	O	O	O	O	O	R	R	Y	Y															
0.47	474	U	U	U	U	U	U	U	U	O	O	O	O	O	O	O	O	O	O															
0.56	564	U	U	U	U	U	U	U	U	R	R	R	R	R	R	R	R	R	Y															
0.68	684	U	U	U	U	U	U	U	U	O	O	O	O	O	O	O	O	O	T															
0.82	824	U	U	U	U	U	U	U	U	O	O	O	O	O	O	O	O	O	V															
1	105	T	T	T	T	T	T	T	T	T	T	T	T	T	T	T	T	T	Y															
1.5	155	U	U	U	U	U	U	U		Z	Z	Z	Z	Z	Z	Z	Z	Z	Z															
2.2	225	U	U	U	U	U	U	U	U	Z	Z	Z	Z	Z	Z	Z	Z	Z	Z															
3.3	335	U	U	U	U	U	U	U		Z	Z	Z	Z	Z	Z	Z	Z	Z	Z	Y	Y	Y	Y	Y	Y	Y	V	V	V	V	V	V	V	V
4.7	475	U	U	U	U	U	U	U	U	Z	Z	Z	Z	Z	Z	Z	Z	Z	Z	V	V	V	V	V	V	Y	V	V	V	V	V	V	V	V
6.8	685	U	U	U	U	U	U			Z	Z	Z	Z	Z						Y	Y	Y	Y	Y	Y		V	V	V	V	V	V	V	V
10	106	U	U	U	U	U	U	U		Z	Z	Z	Z	Z	Z	Y				Y	Y	Y	Y	Y	Y		Y	Y	Y	Y	Y	Y	Y	Y
15	156	T	T	T	T	T	T			Y	Y	Y	Y							A1	A1	A1	A1				A1	A1	A1					
22	226	T	T	T	T	T	T			Y	Y	Y	Y	Y						Y	Y	Y	Y				Y	Y	Y	Y	Y			
33	336	T	T	T	T	T				V	V	V								Y	Y	Y					V	V	V					
47	476	T	T	T	T	T				Y	Y	Y	Y	Y						A1	A1						X	X	X	X				
68	686	U	U	U						V	V									A1	A1						X	X						
100	107	T	T	T						Y	Y	Y	Y							A1	A1						A1	A1						
220	227	U	U							Y	Y	Y																						
330	337									Y	Y																							

MAX HEIGHT												
M	O	P	Q	R	T	U	V	X	Y	Z	A1	
0.95	1.1	1.35	1.40	1.45	1.80	1.9	2.2	2.5	2.80	2.9	3.1	

PACKAGING (TAPING)

Per EIA-481 - Reel Type Size

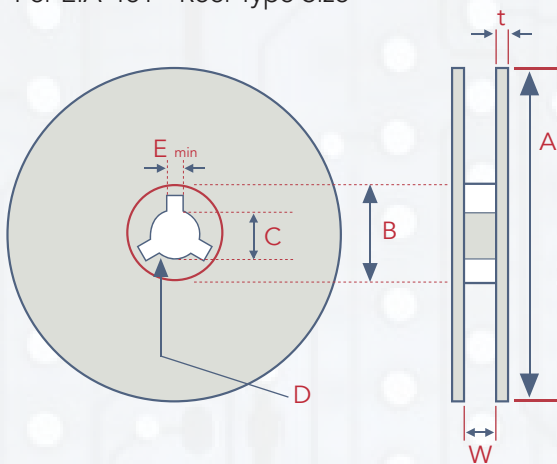

UNIT: mm

SYMBOL	TAPE WIDTH	A	B	C	D	E	W	t
7" Reel	8mm	Ø178±2.0	MINØ50	Ø13±0.5	21±0.8	2.0±0.5	10±0.5	0.9±0.2
	12mm	Ø178±2.0	MINØ50	Ø13±0.5	21±0.8	2.0±0.5	13±0.5	1.2±0.2
10" Reel	8mm	Ø258±2.0	MINØ70	Ø13±0.5	21±0.8	2.0±0.5	10±0.5	1.8±0.2
	12mm	Ø258±2.0	MINØ70	Ø13±0.5	21±0.8	2.0±0.5	13±0.5	2.2±0.2

CarrierTape (Standard)

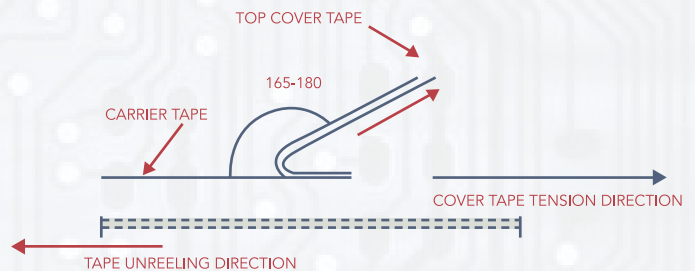

- To peel off the cover tape by the method shown in the right figure apply a peel-off force of 20GF - 60GF (card board); 10GF - 75GF (plastic tape).

-The cover tape should not touch the top or bottom of the chip.

- If the cover tape has been peeled off it may be difficult to remove the chip due to punch-hole clearance, dirt, and debris. Make sure therefore that no paper waste will adhere to and block the absorption nozzle.

- If the cover tape has been peeled off from the top, stick it back on with a suitable adhesive.

- Follow the illustration for the start and end of the winding operation.

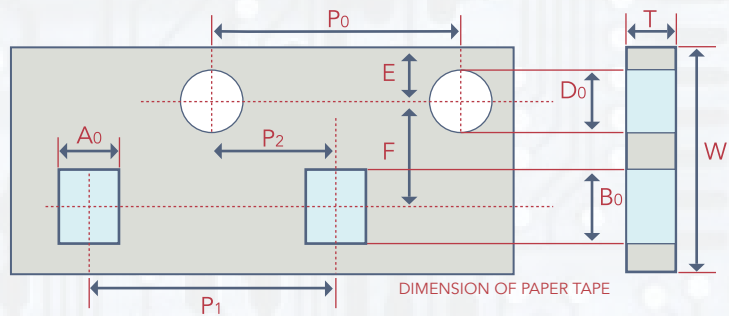
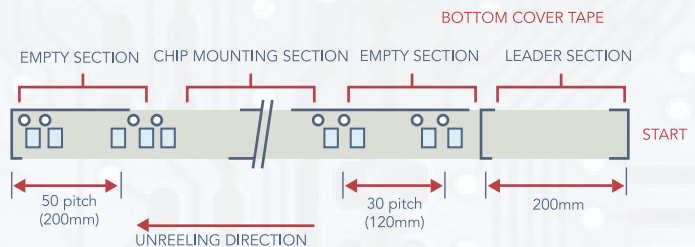

CARDBOARD CARRIER TAPE FOR 01005, 0201, 0402, 0603, 0805, 1206

UNIT=mm

TYPE	A ₀	B ₀	T	K ₀	W	P ₀	10XP ₀	P ₁	P ₂	D ₀	D ₁	E	F	MOUNTING HOLE	STD. REEL QTY 7"	OPTIONAL REEL QTY (10/13")
01005	0.25±0.04	0.45±0.04	0.36±0.05	*	8.0±0.30	4.0±0.10	40.0±0.10	2.0±0.05	2.0±0.05	1.5±0.1	*	1.75±0.1	3.5±0.05	Angular Punch Hole	20,000	50,000 D
0201	0.39±0.07	0.69±0.07	<0.50	*	8.0±0.10	4.0±0.10	40.0±0.10	2.0±0.05	2.0±0.05	1.55±0.05	*	1.75±0.05	3.5±0.05		10,000 15,000	50,000 D
0402	0.7±0.20	1.2±0.20	<0.80	*	8.0±0.10	4.0±0.10	40.0±0.10	2.0±0.05	2.0±0.05	1.55±0.05	*	1.75±0.05	3.5±0.05		10,000	40,000 D 50,000 G
0603	1.1±0.20	1.9±0.20	<1.20	*	8.0±0.10	4.0±0.10	40.0±0.10	2.0±0.05	2.0±0.05	1.55±0.05	*	1.75±0.05	3.5±0.05		4,000	10,000 D 15,000 G
0805	1.65±0.20	2.4±0.20	<01.30	*	8.0±0.10	4.0±0.10	40.0±0.10	2.0±0.05	2.0±0.05	1.55±0.05	*	1.75±0.05	3.5±0.05		4,000	10,000 D 15,000 G 20,000 Q
1206	2.0±0.20	3.6±0.20	<01.30	*	8.0±0.10	4.0±0.10	40.0±0.10	2.0±0.05	2.0±0.05	1.55±0.05	*	1.75±0.05	3.5±0.05		4,000	10,000 D 15,000 G 20,000 Q

PACKAGING (TAPING)

Tape & Reel Dimensions

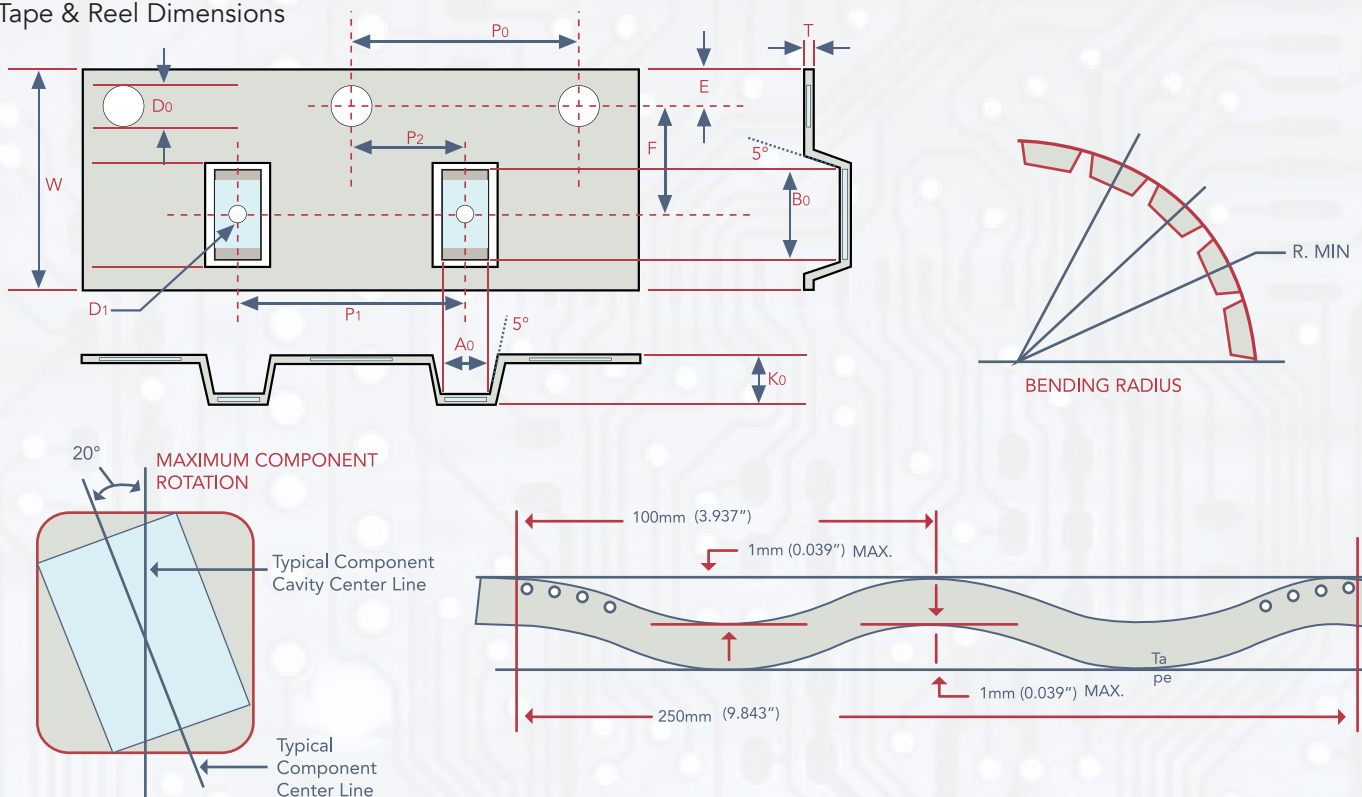

• Embossed plastic carrier tape for 0805/1206/1210/1808/1812/1825/2220 AND 2225 type

TYPE	A ₀	B ₀	T	K ₀	W	P ₀	10XP ₀	P ₁	P ₂	D ₀	D ₁	E	F	MOUNTING HOLE	STD. REEL QTY 7"	OPTIONAL REEL QTY (10/13")
0805	<1.80	<2.70	0.23±0.10	<2.50	8.0±0.20	4.0±0.10	40.0±0.20	4.0±0.10	2.0±0.05	1.5±0.10	1.0±0.10	1.75±0.10	3.5±0.05	Angular Embossed Hole	2,000 3,000	10,000 D 15,000 G
1206	<2.30	<4.00	0.23±0.10	<2.50	8.0±0.20	4.0±0.10	40.0±0.20	4.0±0.10	2.0±0.05	1.5±0.10	1.0±0.10	1.75±0.10	3.5±0.05		2,000 3,000	8,000 D 10,000 G
1210	<3.20	<3.95	0.23±0.10	<3.00	8.0±0.20	4.0±0.10	40.0±0.20	4.0±0.10	2.0±0.05	1.5±0.10	1.0±0.10	1.75±0.10	3.5±0.05		500 1,000 2,000 3,000	4,000 D 8,000 G
1808	<2.50	<5.30	0.25±0.10	<2.50	12.0±0.20	4.0±0.10	40.0±0.20	4.0±0.10	2.0±0.05	1.5±0.10	1.0±0.10	1.75±0.10	5.5±0.10		1,000 2,000 3,000	
1812	<3.90	<5.30	0.25±0.10	<3.50	12.0±0.20	4.0±0.10	40.0±0.20	8.0±0.10	2.0±0.05	1.5±0.10	1.5±0.10	1.75±0.10	5.5±0.10		500 1,000	3,000 D
1825	<6.80	<5.30	0.30±0.10	<3.10	12.0±0.20	4.0±0.10	40.0±0.20	8.0±0.10	2.0±0.05	1.5±0.10	1.5±0.10	1.75±0.10	5.5±0.10		500 1,000	
2220	<5.80	<6.50	0.30±0.10	<3.10	12.0±0.20	4.0±0.10	40.0±0.20	8.0±0.10	2.0±0.05	1.5±0.10	1.5±0.10	1.75±0.10	5.5±0.10		500 700 1,000	
2225	<6.80	<6.50	0.30±0.10	<3.10	12.0±0.20	4.0±0.10	40.0±0.20	8.0±0.10	2.0±0.05	1.5±0.10	1.5±0.10	1.75±0.10	5.5±0.10		500 700	

WARRANTY: All passive components supplied by Calchip Electronics, 59 Steamwhistle Drive, Ivyland, PA, 18974, are under warranty for a period of 2 years from the date of manufacture. Product will meet or exceed all reliability and test specifications expressed by Calchip for the above mentioned time period provided storage conditions (stated below) are met. Product Storage Instructions:

- 1) Product must be kept away from direct sunlight.
- 2) Product must be stored in the following conditions - Temperature; 5 to 35 degrees Celsius / 40 to 95 degrees Fahrenheit Humidity; 45 to 85%
- 3) Product to be kept free of moisture, dirt and debris.

WHEN THESE CONDITIONS ARE NOT MET, PRODUCT LIFE COULD BE SHORTENED***

NOTICE: Specifications are subject to change without notice. Contact your nearest Cal-Chip Sales Office for the latest specifications. All statements, information and data given herein are believed to be accurate and reliable, but are presented without guarantee, warranty, or responsibility of any kind, expressed or implied. Statements or suggestions concerning possible use of our products are made without representation or warranty that any such use is free of patent infringement and are not recommendations to infringe any patent. The user should not assume that all safety measures are indicated or that other measures may not be required. Specifications are typical and may not apply to all applications.

BARCODE LABEL



CCE P/N GMC21X5R475K50NT



Cust PN



QTY 2000 ea



Date Code 2132 32nd week of 2021



Lot Code 2065112

