

PART NUMBER		STATUS	CKTS	DIM A	DIM B	DIM C	DIM D	POWER POS.	DIM E
TIN	TIN PREVIOUSLY TINLEAD								
762910008	762911008	NOT TOOLED	8	8.19	4.40	5.65	4.25	-	10.84
762910014	762911014	NOT TOOLED	14	10.44	6.65	7.90	6.50	-	10.84
762910020	762911020	NOT TOOLED	20	12.69	8.90	10.15	8.75	-	10.84
762910026	762911026	NOT TOOLED	26	14.94	11.15	12.40	11.00	-	10.84
762910032	762911032	NOT TOOLED	32	17.19	13.40	14.65	13.25	-	10.84
762910038	762911038		38	19.44	15.60	16.90	15.50	-	10.84
762910044	762911044	NOT TOOLED	44	21.69	17.90	19.15	17.75	-	10.84
762910050	762911050	NOT TOOLED	50	23.94	20.15	21.40	20.00	-	10.84
762910056	762911056	NOT TOOLED	56	26.19	22.40	23.65	22.25	-	10.84
762910062	762911062	NOT TOOLED	62	28.44	24.65	25.90	24.50	-	10.84
762910068	762911068		68	30.69	26.90	28.15	26.75	-	10.84
762910074	762911074	NOT TOOLED	74	32.94	29.15	30.40	29.00	-	10.84
762910080	762911080	NOT TOOLED	80	35.19	31.40	32.65	31.25	-	10.84
762910086	762911086	NOT TOOLED	86	37.44	33.65	34.90	33.50	-	10.84
762910092	762911092	NOT TOOLED	92	39.69	35.90	37.15	35.75	-	10.84
762910098	762911098	NOT TOOLED	98	41.94	38.15	39.40	38.00	-	10.84
762910104	762911104	NOT TOOLED	104	44.19	40.40	41.65	40.25	-	10.84
762910110	762911110	NOT TOOLED	110	46.44	42.65	43.90	42.50	-	10.84
762910116	762911116	NOT TOOLED	116	48.69	44.90	46.15	44.75	-	10.84
762910122	762911122	NOT TOOLED	122	50.94	47.15	48.40	47.00	-	10.84
762910128	762911128	NOT TOOLED	128	53.19	49.40	50.65	49.25	-	10.84
762910134	762911134	NOT TOOLED	134	55.44	51.65	52.90	51.50	-	10.84
762910140	762911140		140	57.69	53.90	55.15	53.75	-	10.84
762910146	762911146	NOT TOOLED	146	59.94	56.15	57.40	56.00	-	10.84
762910152	762911152	NOT TOOLED	152	62.19	58.40	59.65	58.25	-	10.84
762910158	762911158	NOT TOOLED	158	64.44	60.65	61.90	60.50	-	10.84
762910164	762911164	NOT TOOLED	164	66.69	62.90	64.15	62.75	-	10.84
762910170	762911170		170	68.94	65.15	66.40	65.00	-	10.84
762910171	762911171		170	68.94	65.15	66.40	65.00	2	10.84
762910172	762911172		170	68.94	65.15	66.40	65.00	28	10.84
762910178	762911078	NOT TOOLED	178	73.44	69.65	70.90	69.50	-	10.84
762910184	762911184	NOT TOOLED	184	75.69	71.90	73.15	71.75	-	10.84
762910190	762911190	NOT TOOLED	190	77.94	74.15	75.40	74.00	-	10.84
762910196	762911196	NOT TOOLED	196	80.19	76.40	77.65	76.25	-	10.84
762910202	762911202	NOT TOOLED	202	82.44	78.65	79.90	78.50	-	10.84
762910208	762911208	NOT TOOLED	208	84.69	80.90	82.15	80.75	-	10.84
762910214	762911214	NOT TOOLED	214	86.94	83.15	84.40	83.00	-	10.84
762910220	762911220	NOT TOOLED	220	89.19	85.40	86.65	85.25	-	10.84
762910226	762911226		226	91.44	87.65	88.90	87.50	-	10.84
762912226	762913226		226	91.44	87.65	88.90	87.50	-	10.15
762910232	762911232	NOT TOOLED	232	93.69	89.90	91.15	89.75	-	10.84
762910238	762911238	NOT TOOLED	238	95.94	92.15	93.40	92.00	-	10.84
762910244	762911244	NOT TOOLED	244	98.19	94.40	95.65	94.25	-	10.84
762910250	762911250		25	100.44	96.65	97.90	96.50	-	10.84

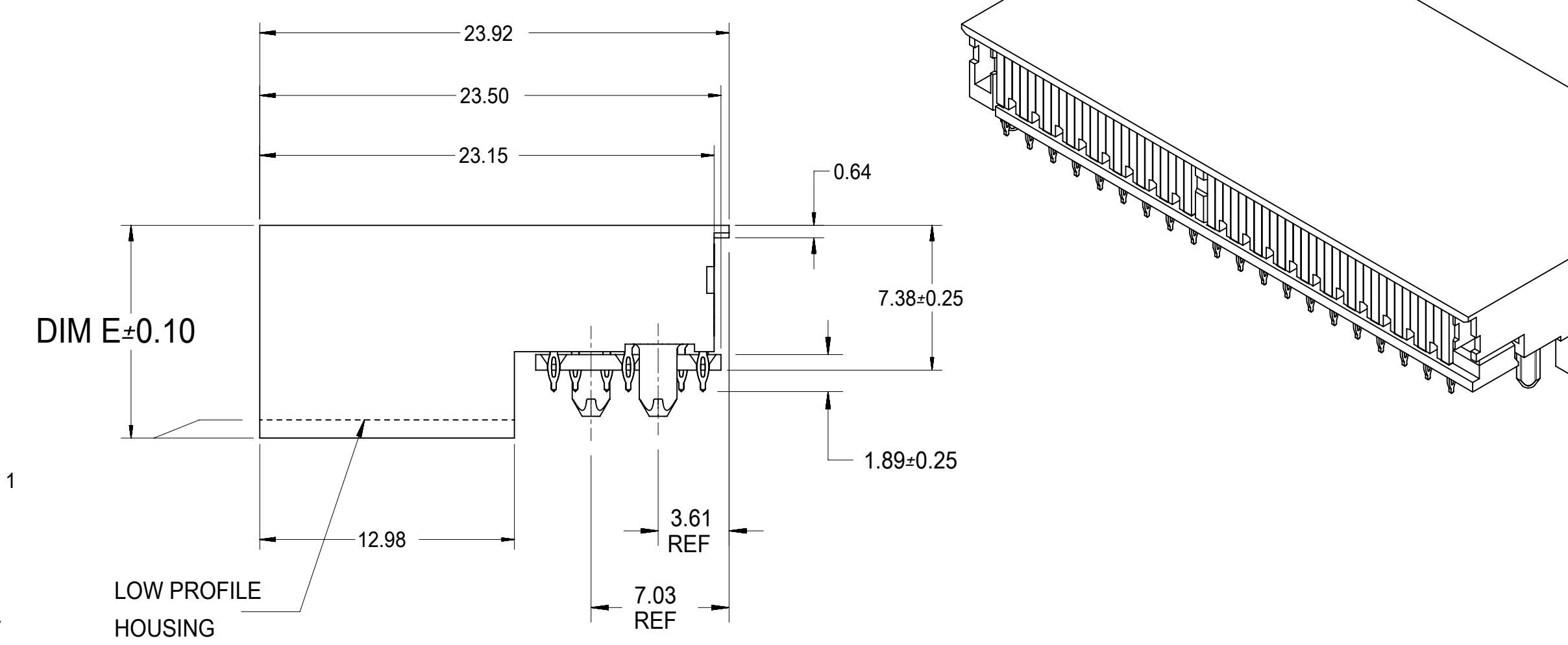

LOW PROFILE

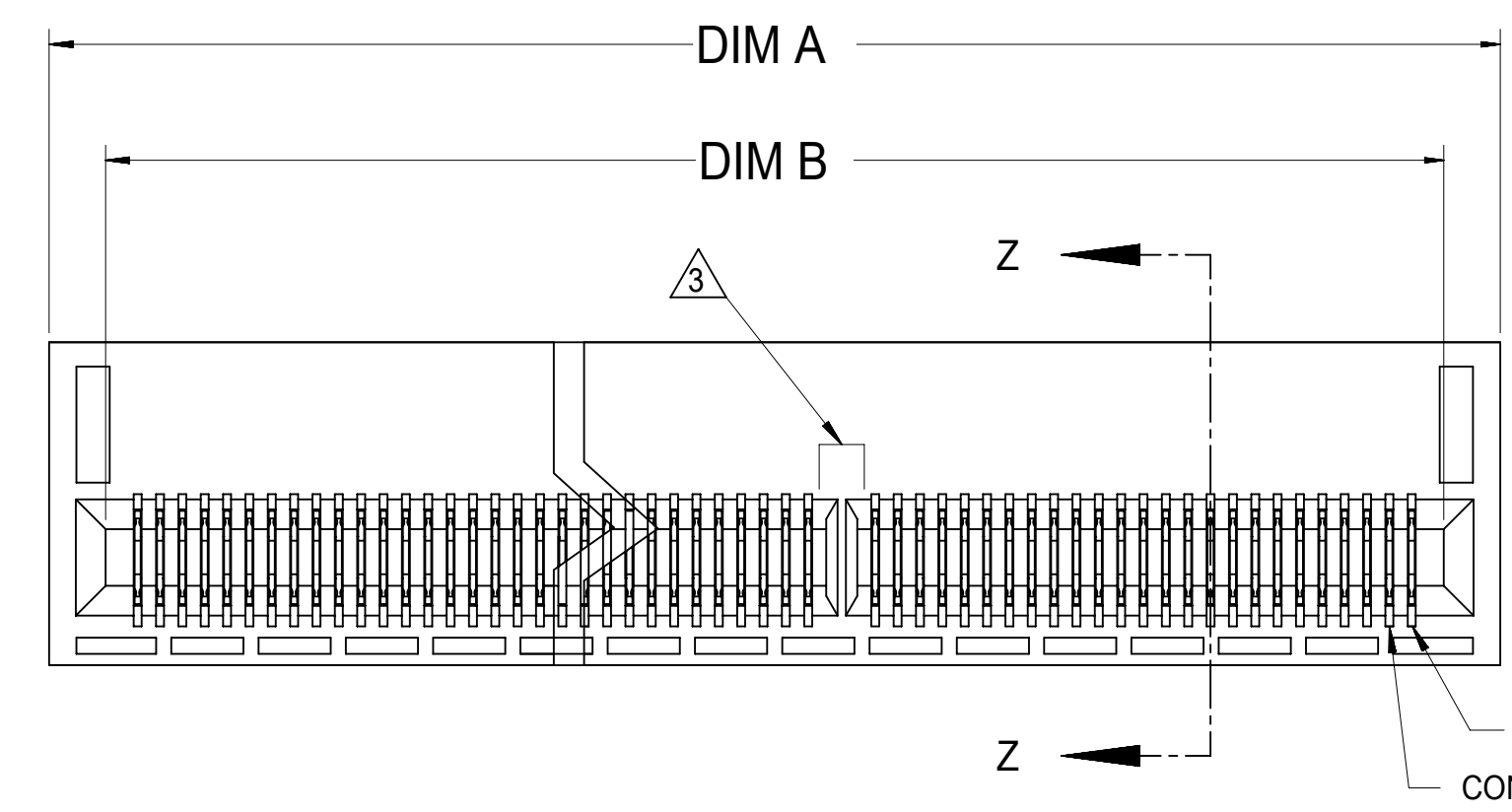
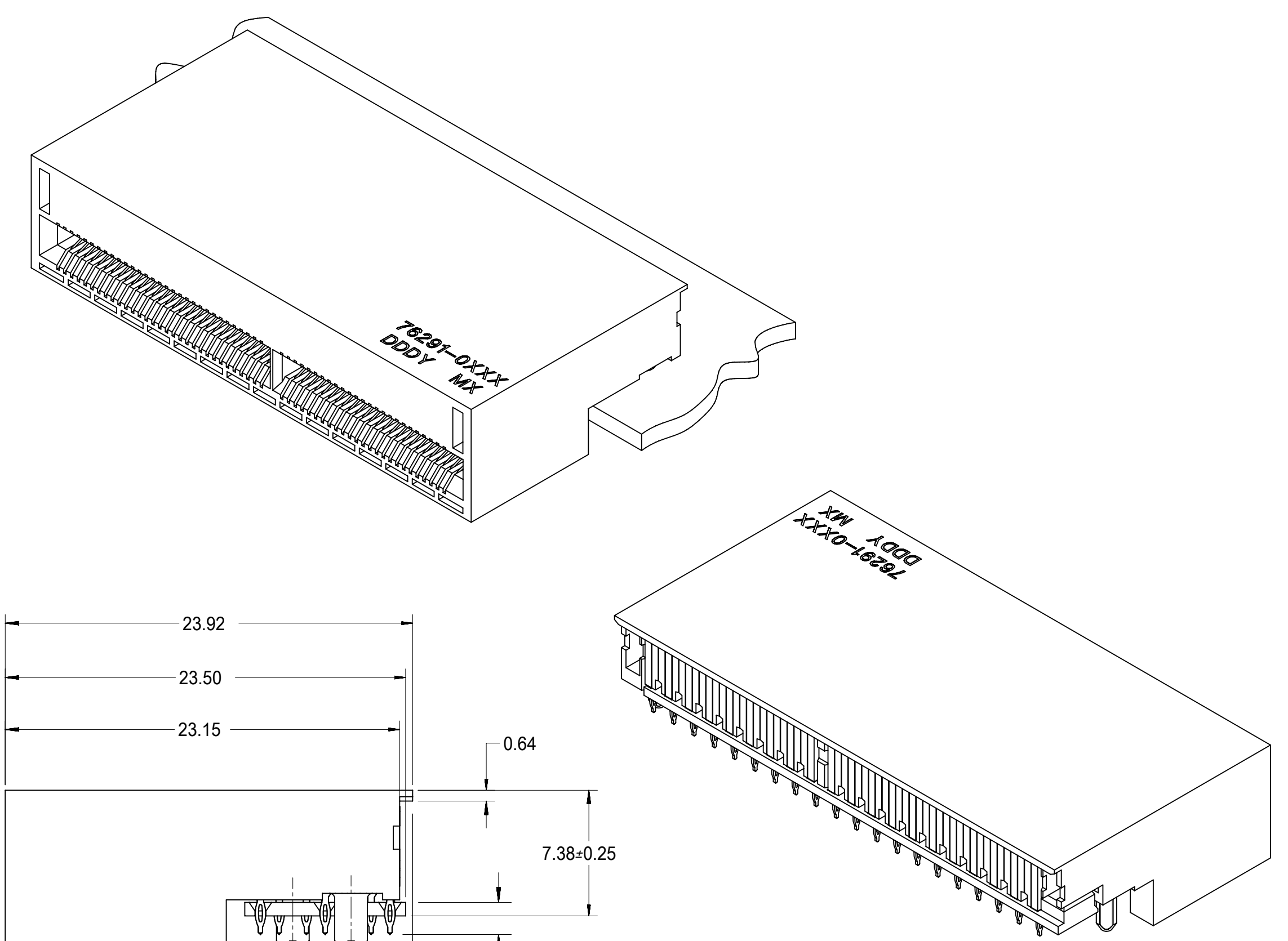
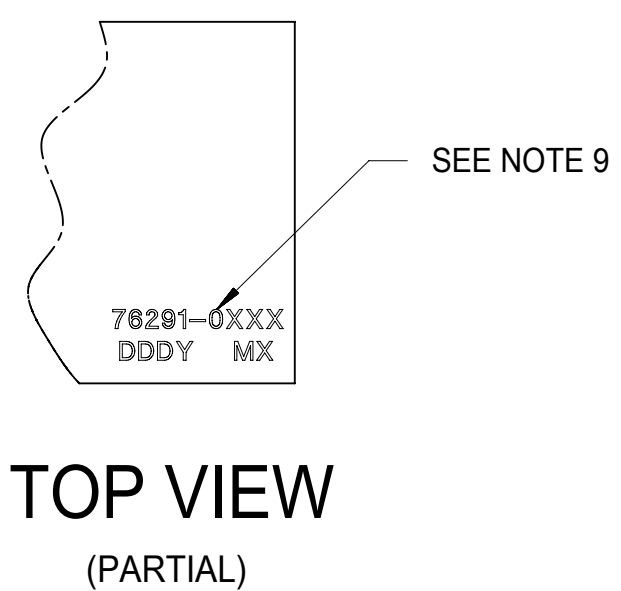
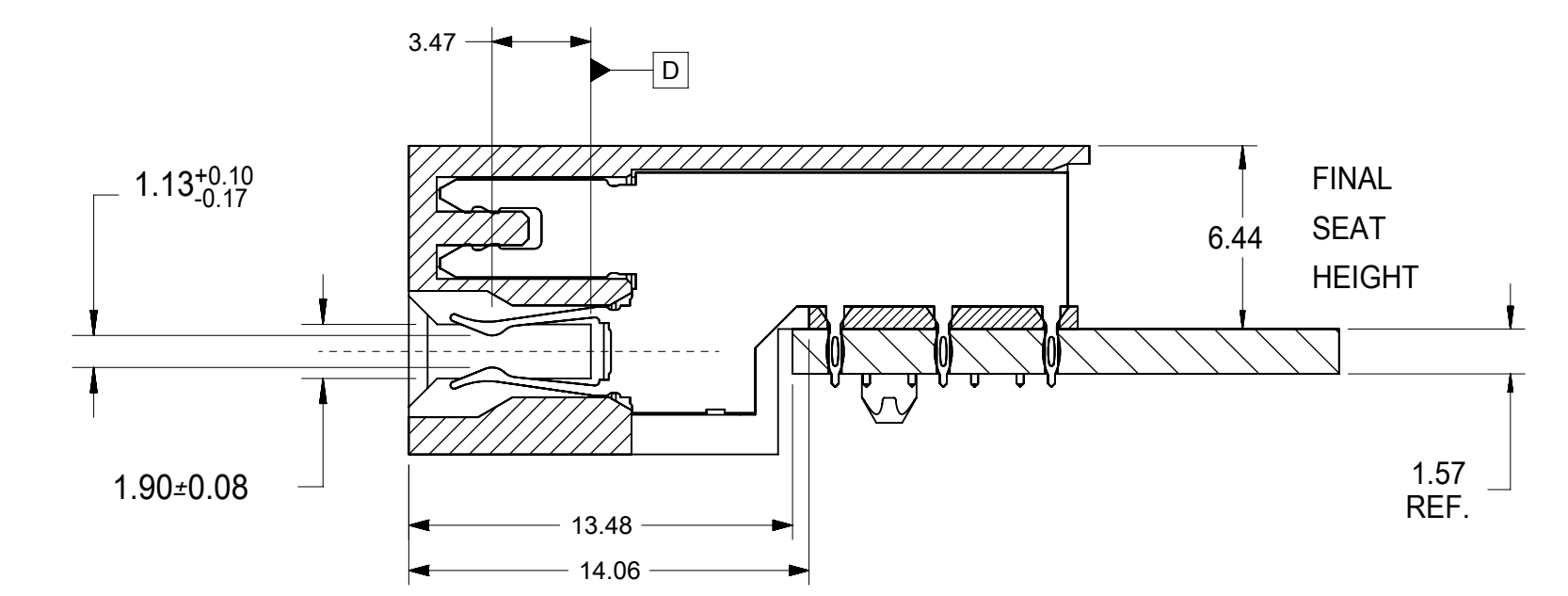
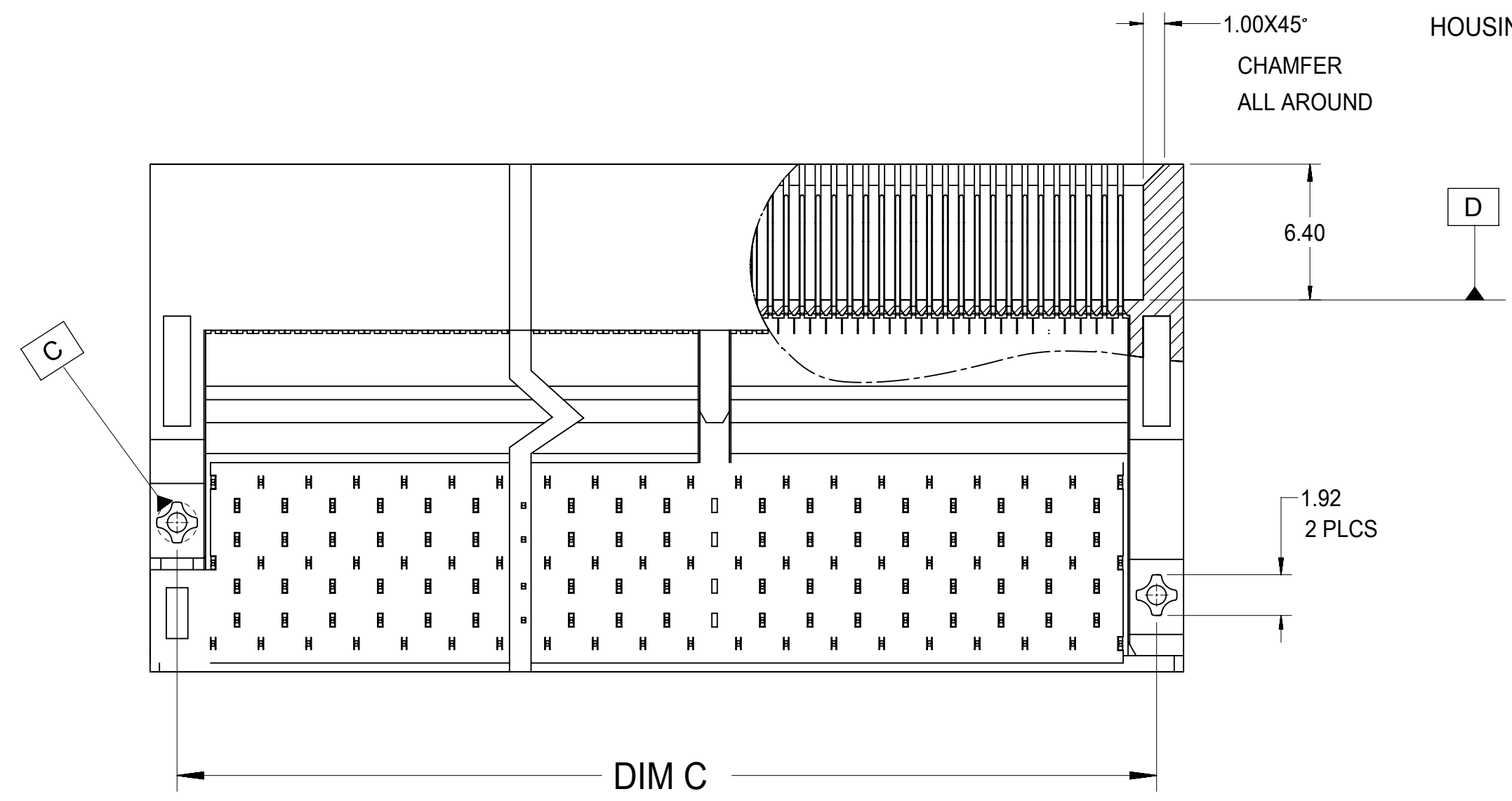

- NOTES:
- MATERIAL -
CONNECTOR HOUSING - GLASS FILLED LCP, 94V-0, BLACK
OVERMOLDING ON TERMINALS: GLASS FILLED LCP, 94V-0, BLACK
TERMINALS: COPPER ALLOY, SPRING TEMPER
 - TERMINAL FINISH:
CONTACT AREA: .75m HARD GOLD OVER 3.8m MIN NICKEL.
COMPLIANT AREA: .75-1.50m TIN OVER .75m - 1.50m NICKEL.
 - FOR CIRCUIT SIZES GREATER THAN 170, A CENTER ALIGNMENT KEY WILL BE USED.
 - REFER TO PS-76291-001 PRODUCT SPEC FOR ALL ELECTRICAL, MECHANICAL, AND ENVIRONMENTAL SPECIFICATIONS.
 - REFER TO PK-76291-001 FOR ALL PACKAGING SPECIFICATIONS.
 - REFER TO AS-76291-001 FOR BOARD APPLICATION INFORMATION.
 - MODULE BOARD CONTACT PAD PLATING TO BE .76m MIN HARD GOLD OVER 2.54m MIN NICKEL
 - MODULE BOARD CONTACT PAD SURFACE ROUGHNESS NOT TO EXCEED Ra 0.2m.
 - PART TO BE LASER MARKED WITH PART NUMBER, WHERE XXX IS THE CIRCUIT SIZE OR POWER WAFER OPTION, MANUFACTURING FACILITY, AND DATE CODE IN THE FORMAT OF: DAY OF THE YEAR AND LAST DIGIT OF THE YEAR: DDDY

SYMBOLS		THIS DRAWING CONTAINS INFORMATION THAT IS PROPRIETARY TO MOLEX ELECTRONIC TECHNOLOGIES, LLC AND SHOULD NOT BE USED WITHOUT WRITTEN PERMISSION	
▽ = 0	mm	SCALE	NTS
▽ = 0	GENERAL TOLERANCES (UNLESS SPECIFIED)		
▽ = 0	ANGULAR TOL	±	0.5°
▽ = 0	4 PLACES	±	
▽ = 0	3 PLACES	±	
▽ = 0	2 PLACES	±	0.13
▽ = 0	1 PLACE	±	0.25
▽ = 0	0 PLACES	±	
■ = 0	DRAFT WHERE APPLICABLE MUST REMAIN WITHIN DIMENSIONS		
▽ = 0	THIRD ANGLE PROJECTION	DRAWING	SERIES
		D-SIZE	76291
CURRENT REV DESC: MIGRATED TO NX		EC NO: 611387	
		DRWN: BARWANKAR 2019/01/31	
		CHK'D: VMANICKAM 2019/02/01	
		APPR: SHLENI 2019/02/13	
		INITIAL REVISION:	
		DRWN: HAVERY 2008/07/14	
		APPR: MBANAKIS 2008/07/22	
DOCUMENT NUMBER	DOC TYPE	DOC PART	REVISION
SD-76291-001	PSD	001	T
MATERIAL NUMBER	CUSTOMER	SHEET NUMBER	
SEE CHART	GENERAL MARKET	1 OF 3	

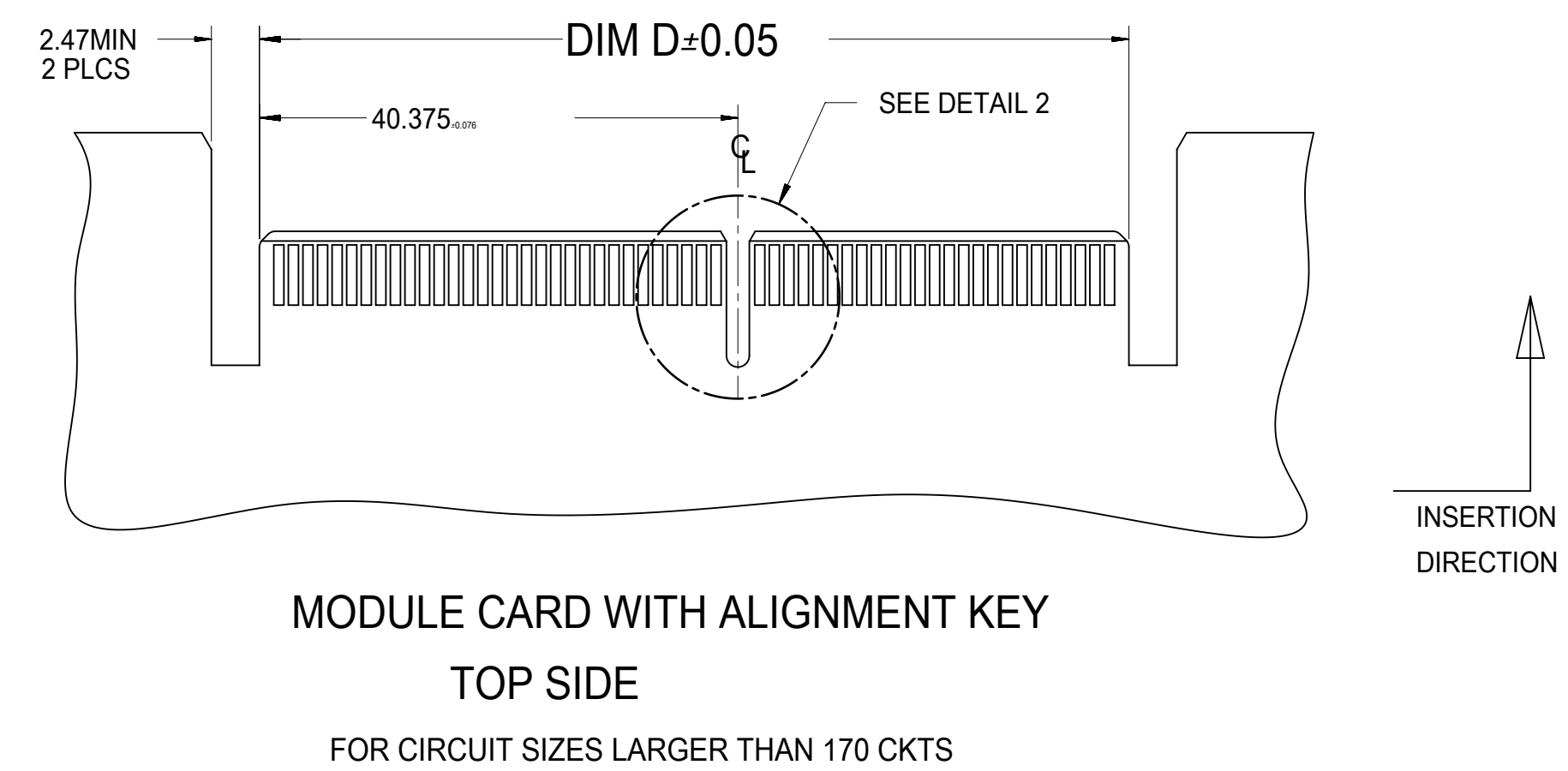
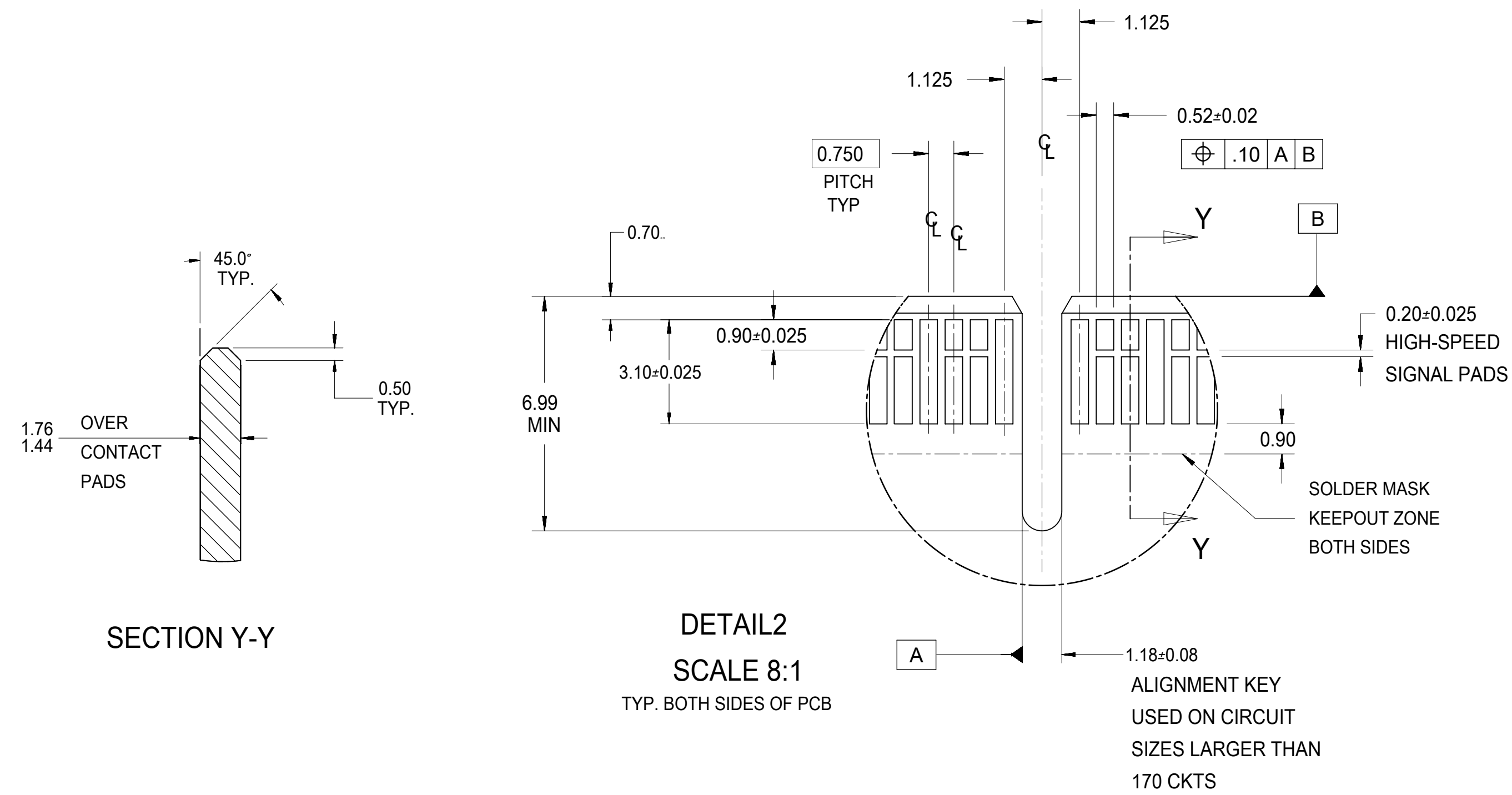
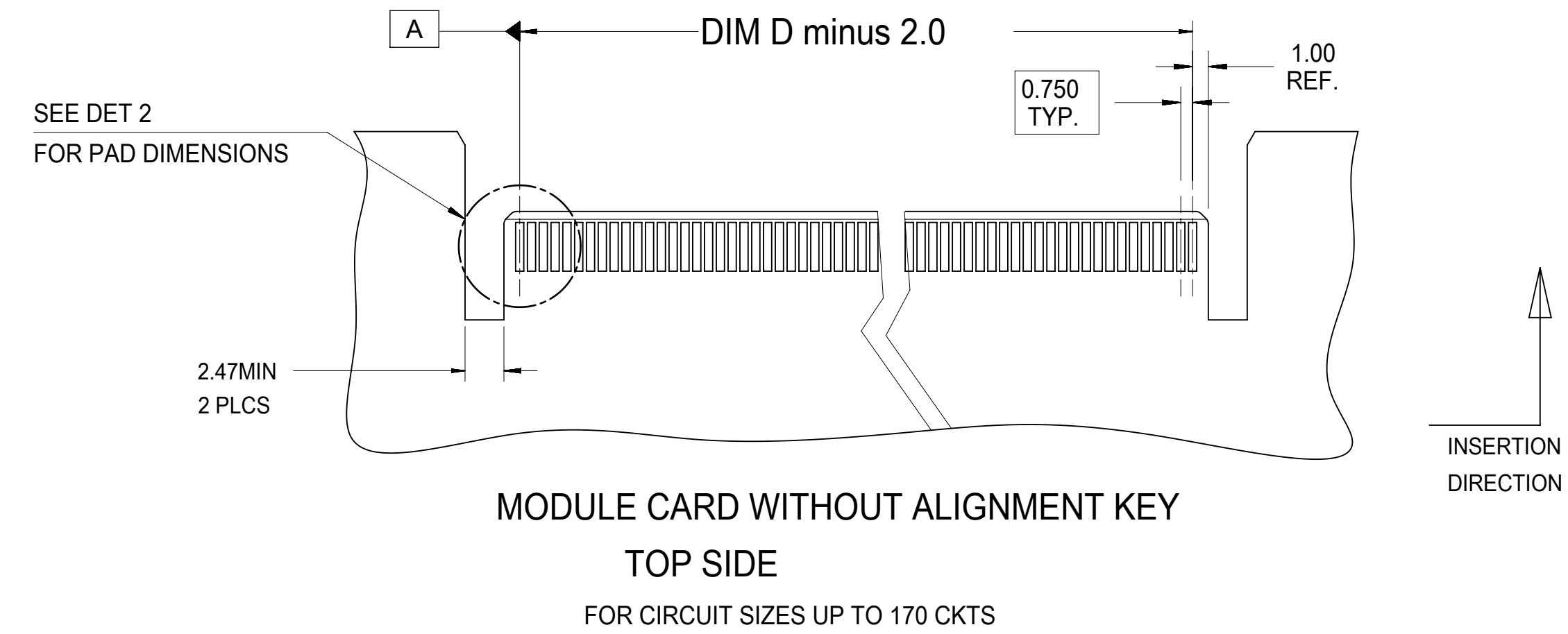
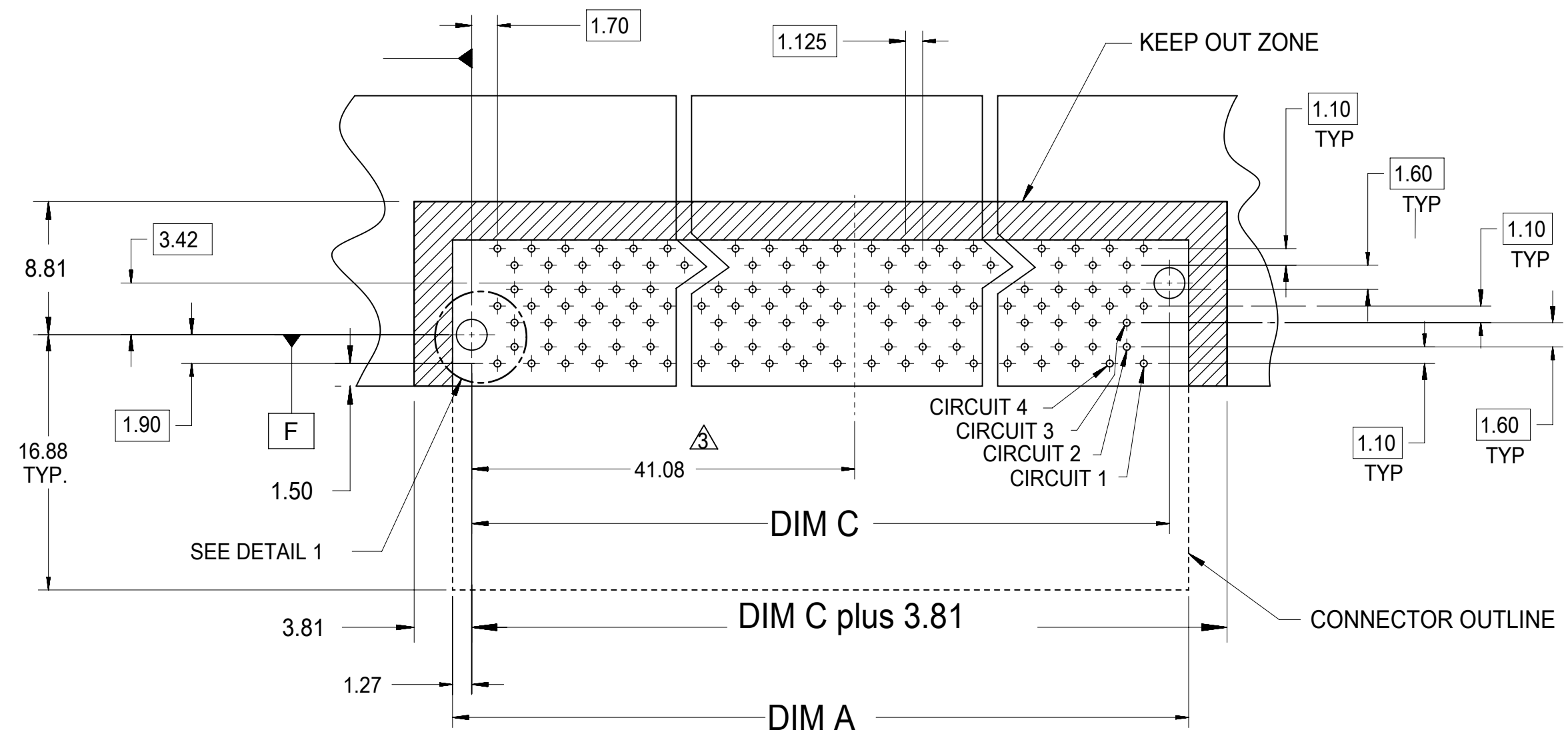
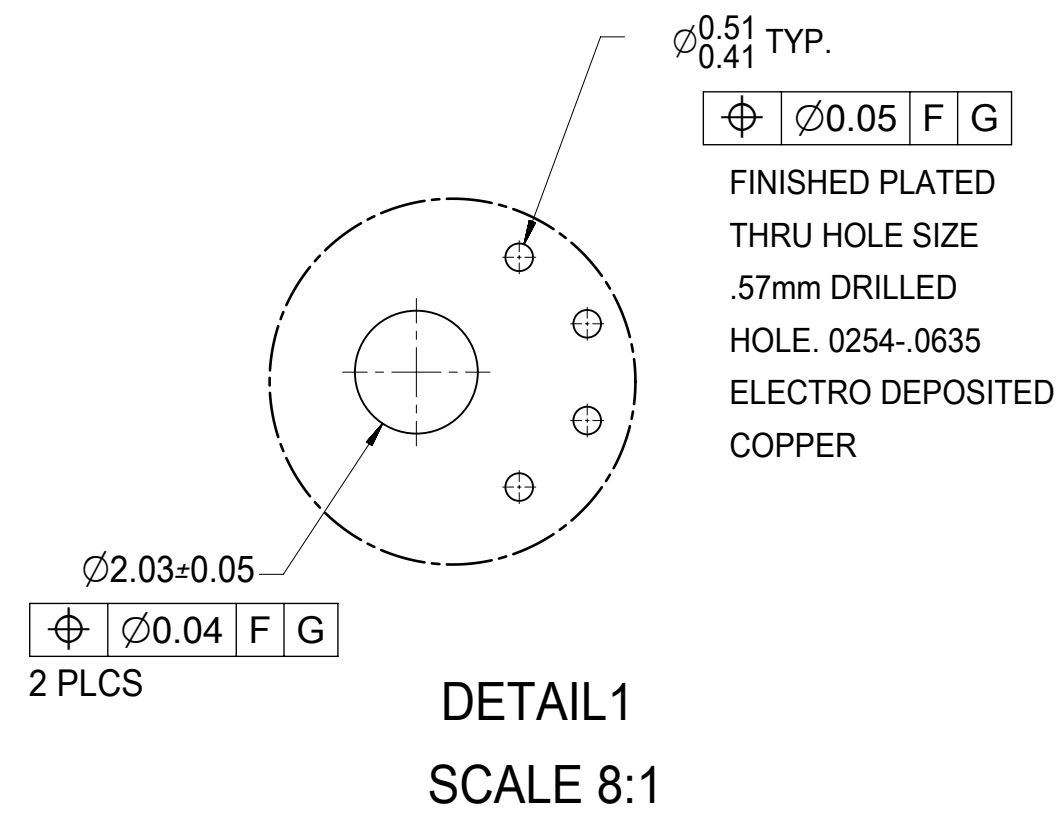

SYMBOLS	THIS DRAWING CONTAINS INFORMATION THAT IS PROPRIETARY TO MOLEX ELECTRONIC TECHNOLOGIES, LLC AND SHOULD NOT BE USED WITHOUT WRITTEN PERMISSION		
	DIMENSION UNITS	SCALE	CURRENT REV DESC: MIGRATED TO NX
$\nabla = 0$	mm	NTS	molex .75 COPLANAR CONNECTOR GENERAL SALES DRAWING PRODUCT CUSTOMER DRAWING
$\nabla = 0$	GENERAL TOLERANCES (UNLESS SPECIFIED)		
$\nabla = 0$	ANGULAR TOL $\pm 0.5^\circ$		
$\nabla = 0$	4 PLACES \pm		
$\nabla = 0$	3 PLACES \pm		
$\nabla = 0$	2 PLACES ± 0.13		
$\nabla = 0$	1 PLACE ± 0.25		EC NO: 611387 DRWN: BARWANKAR 2019/01/31 CHK'D: VMANICKAM 2019/02/01 APPR: SHLENI 2019/02/13
$\nabla = 0$	0 PLACES \pm		INITIAL REVISION: DRWN: HAVERY 2008/07/14 APPR: MBANAKIS 2008/07/22
$\square = 0$	DRAFT WHERE APPLICABLE MUST REMAIN WITHIN DIMENSIONS		THIRD ANGLE PROJECTION DRAWING SERIES D-SIZE 76291
DOCUMENT STATUS			DOCUMENT NUMBER SD-76291-001
RELEASE DATE			DOC TYPE PSD
2019/02/13 07:54:33			DOC PART 001
			REVISION T
			MATERIAL NUMBER SEE CHART
			CUSTOMER GENERAL MARKET
			SHEET NUMBER 2 OF 3

PCB PIN-OUT ASSIGNMENTS

(TOP SIDE OF BOARD SHOWN)

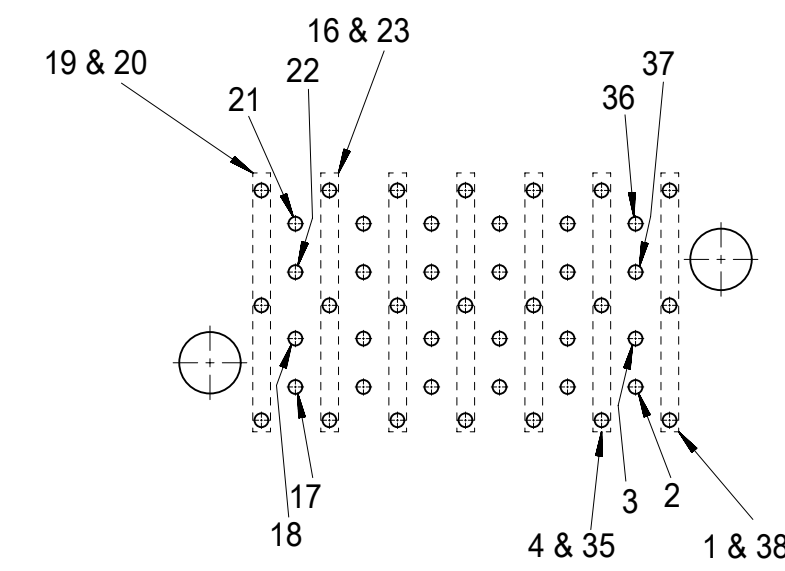
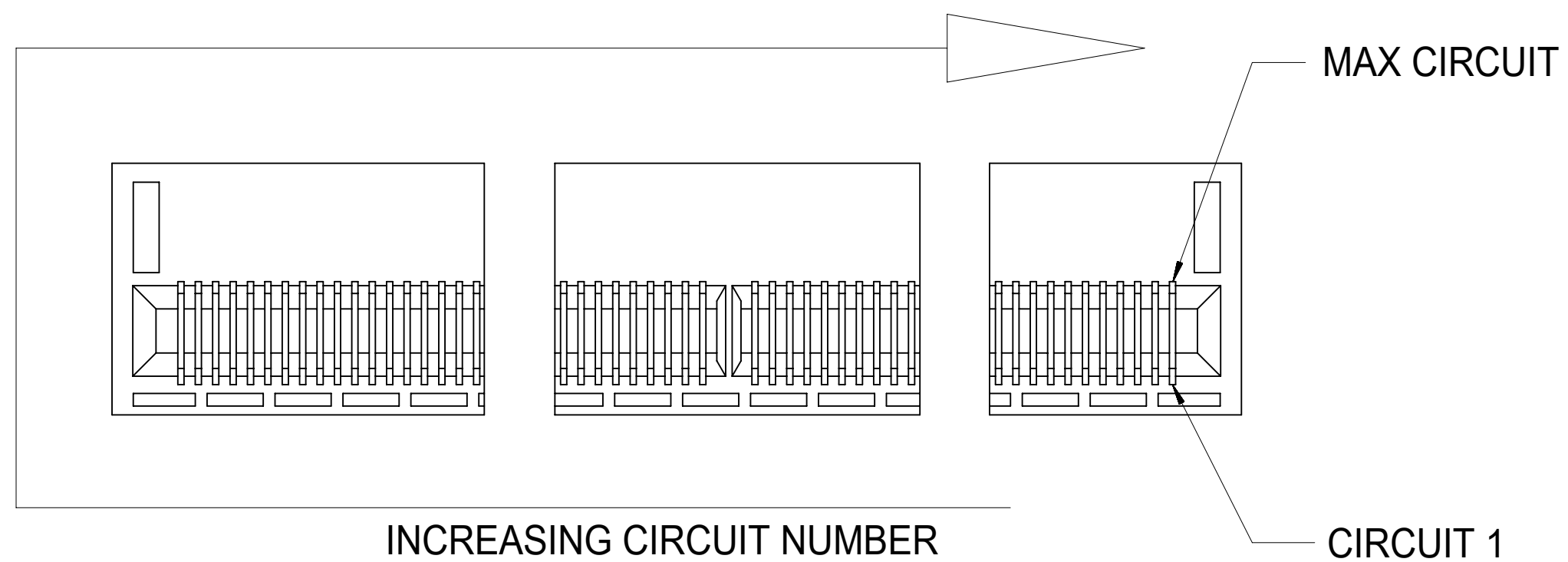

76291-0038

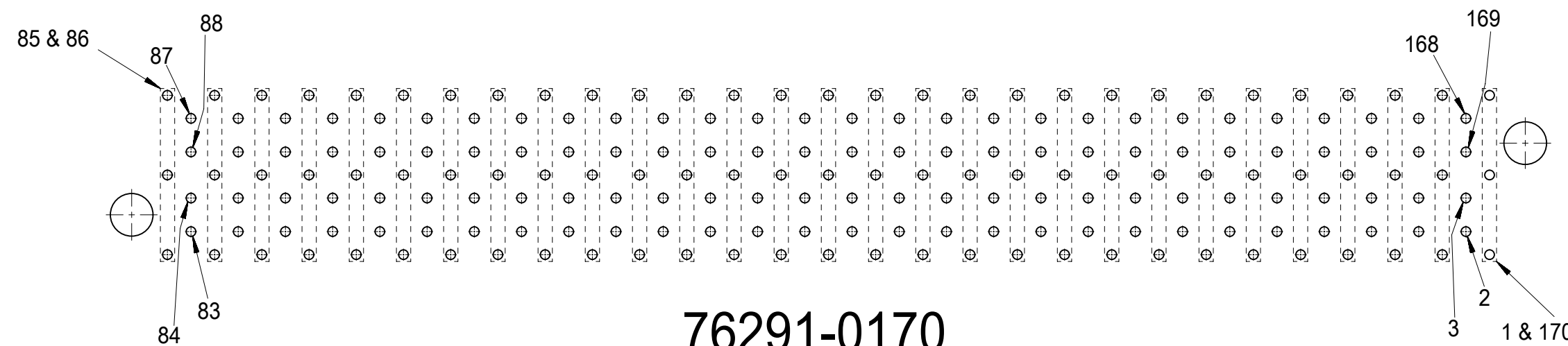

76291-0170

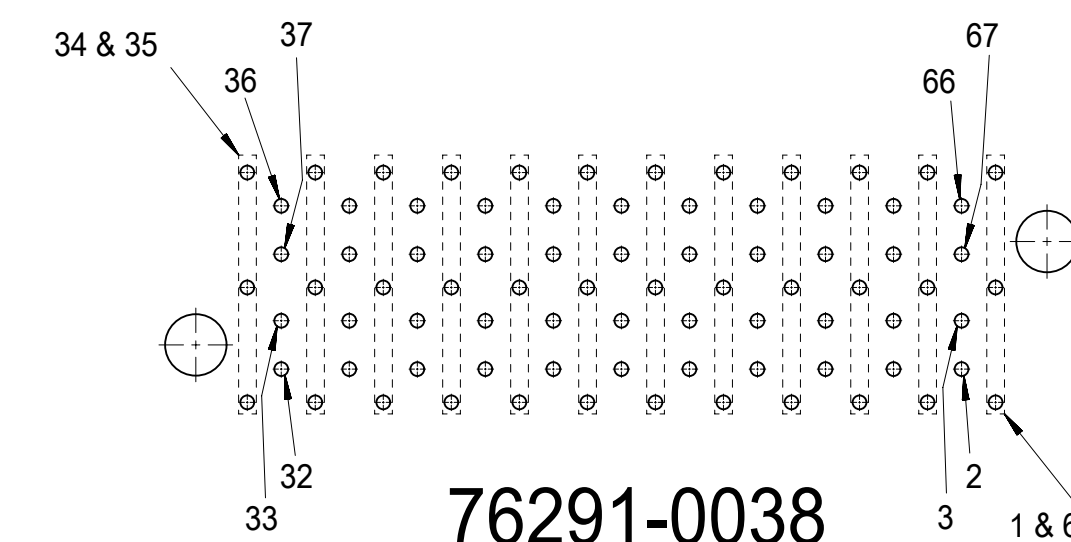

76291-0038

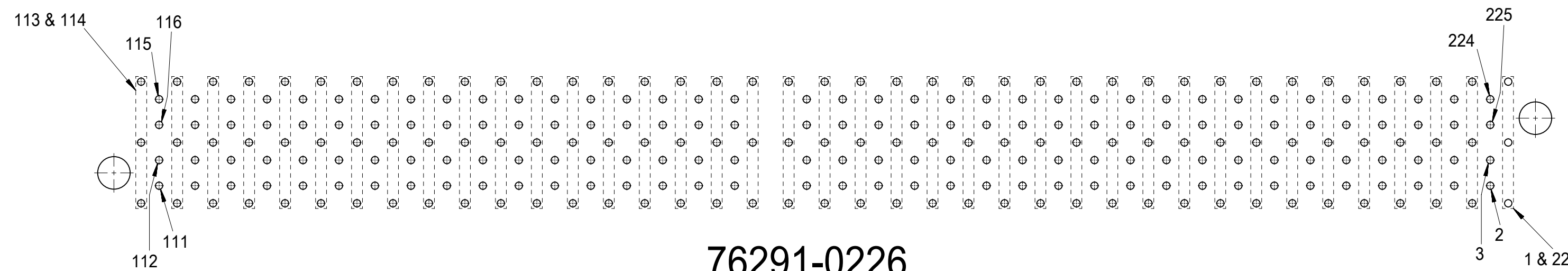

76291-0226

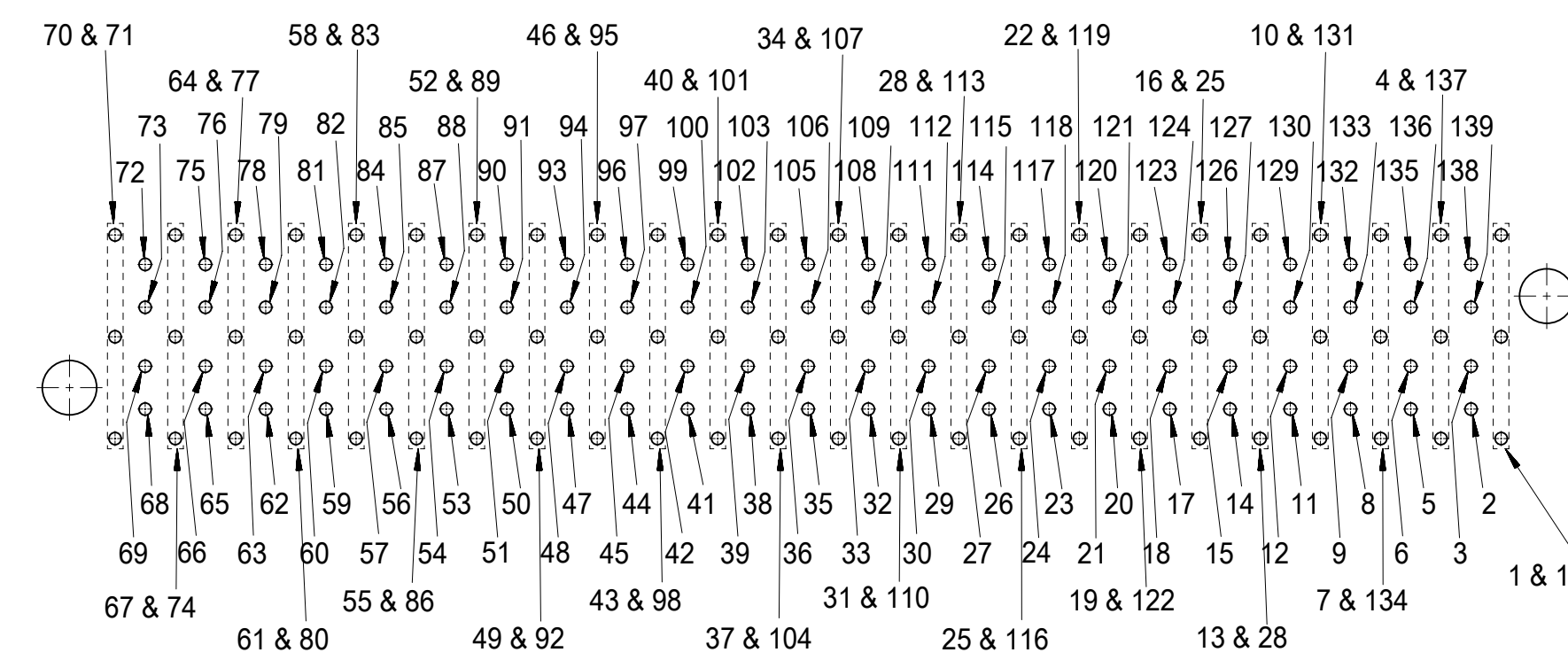

76291-0140

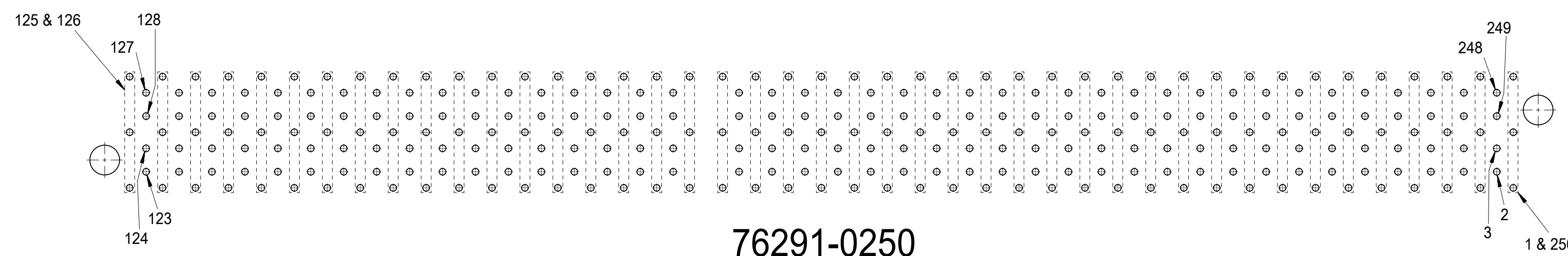

76291-0250

FRONT EDGE OF PCB

NOTES ON CIRCUIT DESIGNATIONS:
 1. CIRCUIT 1 STARTS AT LOWER RIGHT HAND CORNER AND INCREASES TO THE LEFT ACROSS THE BOTTOM AND INCREASES TO THE RIGHT ACROSS THE TOP.
 2. THERE IS NOT A 1:1 CORRESPONDENCE BETWEEN THE CIRCUIT NUMBER AND THE TAIL HOLE LOCATIONS. EACH GROUND HAS TWO CONTACTS AND THREE TAILS. THE BOXES AROUND THE THREE VERTICAL HOLES INDICATE THE UPPER AND LOWER GROUND CONTACTS SHARE THE THREE TAIL HOLE LOCATIONS.

SYMBOLS	THIS DRAWING CONTAINS INFORMATION THAT IS PROPRIETARY TO MOLEX ELECTRONIC TECHNOLOGIES, LLC AND SHOULD NOT BE USED WITHOUT WRITTEN PERMISSION		CURRENT REV DESC: MIGRATED TO NX		
	DIMENSION UNITS	SCALE			
= 0	mm	NTS			.75 COPLANAR CONNECTOR GENERAL SALES DRAWING
= 0	GENERAL TOLERANCES (UNLESS SPECIFIED)				
= 0	ANGULAR TOL ± 0.5°		EC NO: 611387		PRODUCT CUSTOMER DRAWING
= 0	4 PLACES ±		DRWN: BARWANKAR 2019/01/31		
= 0	3 PLACES ±		CHK'D: VMANICKAM 2019/02/01		DOCUMENT NUMBER: SD-76291-001 DOC TYPE: PSD DOC PART: 001 REVISION: T
= 0	2 PLACES ± 0.13		APPR: SHLENI 2019/02/13		
= 0	1 PLACE ± 0.25		INITIAL REVISION:		MATERIAL NUMBER: SEE CHART CUSTOMER: GENERAL MARKET SHEET NUMBER: 3 OF 3
= 0	0 PLACES ±		DRWN: HAVERY 2008/07/14		
= 0	DRAFT WHERE APPLICABLE MUST REMAIN WITHIN DIMENSIONS		APPR: MBANAKIS 2008/07/22		
= 0	THIRD ANGLE PROJECTION		DRAWING SERIES: D-SIZE 76291		