

Features:

- AC operating voltage from 11V to 1000V
- DC operating voltage from 14V to 1465V
- Peak current up to 10000A
- Energy handling up to 990J
- UL1449 certified file no. E476752
- Operating temperature range -40°C to +85°C
- Crimped and short lead styles available
- 100% RoHS compliant and lead free without exemption
- Halogen free
- REACH compliant



RV Electrical Specifications – 5 mm

Part Number	V _N (1 mA) (V)	V _{RMS} (V)	V _{DC} (V)	V _C (V)	I _C (8/20 uSec) (A)	I _{MAX} (8/20 uSec) (A)	W _{MAX} (10/1000 uSec) (J)	P _{MAX} (W)	C _{TYP} (@ 1 kHz) (pF)	t _{MAX} (mm)
RV180K05	18	11	14	40	1	100	0.4	0.01	1400	4.5
RV220K05	22	14	18	48	1	100	0.5	0.01	1150	4.5
RV270K05	27	17	22	60	1	100	0.6	0.01	930	4.5
RV330K05	33	20	26	73	1	100	0.8	0.01	760	4.5
RV390K05	39	25	31	80	1	100	0.9	0.01	640	4.5
RV470K05	47	30	38	104	1	100	1.1	0.01	530	4.5
RV560K05	56	35	45	123	1	100	1.6	0.01	450	4.5
RV680K05	68	40	56	145	1	100	2.5	0.01	370	4.5
RV820K05	82	50	65	150	5	400	2.5	0.10	300	4.1
RV101K05	100	60	85	175	5	400	3.0	0.10	250	4.3
RV121K05	120	75	100	210	5	400	4.0	0.10	210	4.5
RV151K05	150	95	125	260	5	400	4.8	0.10	165	4.8
RV181K05	180	115	150	320	5	400	5.9	0.10	140	4.3
RV201K05	200	130	170	355	5	400	6.5	0.10	125	4.4
RV221K05	220	140	180	380	5	400	7.0	0.10	110	4.5
RV241K05	240	150	200	415	5	400	8.0	0.10	100	4.6
RV271K05	270	175	225	475	5	400	8.5	0.10	95	4.9
RV301K05	300	190	250	520	5	400	9.0	0.10	85	5.0
RV331K05	330	210	275	570	5	400	9.5	0.10	75	5.1
RV361K05	360	230	300	620	5	400	10.0	0.10	70	5.2
RV391K05	390	250	320	675	5	400	12.0	0.10	65	5.4
RV431K05	430	275	350	745	5	400	13.0	0.10	60	5.7
RV471K05	470	300	385	810	5	400	15.0	0.10	55	6.0
RV511K05	510	320	415	845	5	400	16.0	0.10	50	6.2
RV561K05	560	350	460	920	5	400	16.8	0.10	45	6.2

tmax = maximum part thickness

RV Electrical Specifications – 7 mm

Part Number	V _N (1 mA) (V)	V _{RMS} (V)	V _{DC} (V)	V _C (V)	I _C (8/20 uSec) (A)	I _{MAX} (8/20 uSec) (A)	W _{MAX} (10/1000 uSec) (J)	P _{MAX} (W)	C _{TYP} (@ 1 kHz) (pF)	t _{MAX} (mm)
RV180K07	18	11	14	36	2.5	250	0.9	0.02	2800	4.5
RV220K07	22	14	18	43	2.5	250	1.1	0.02	2300	4.6
RV270K07	27	17	22	53	2.5	250	1.4	0.02	1800	4.7
RV330K07	33	20	26	65	2.5	250	1.7	0.02	1500	4.9
RV390K07	39	25	31	77	2.5	250	2.1	0.02	1300	4.8
RV470K07	47	30	38	93	2.5	250	2.5	0.02	1100	4.9
RV560K07	56	35	45	110	2.5	250	3.1	0.02	890	5.0
RV680K07	68	40	56	135	2.5	250	3.6	0.02	740	5.2
RV820K07	82	50	65	135	10	1200	5.5	0.25	600	4.1
RV101K07	100	60	85	165	10	1200	6.5	0.25	500	4.3
RV121K07	120	75	100	200	10	1200	7.8	0.25	420	4.5

RV Electrical Specifications – 7 mm

Part Number	V _N (1 mA) (V)	V _{RMS} (V)	V _{DC} (V)	V _C (V)	I _C (8/20 uSec) (A)	I _{MAX} (8/20 uSec) (A)	W _{MAX} (10/1000 uSec) (J)	P _{MAX} (W)	C _{TYP} (@ 1 kHz) (pF)	t _{MAX} (mm)
RV151K07	150	95	125	250	10	1200	9.7	0.25	330	4.8
RV181K07	180	115	150	300	10	1200	11.7	0.25	280	4.3
RV201K07	200	130	170	340	10	1200	13.0	0.25	250	4.4
RV221K07	220	140	180	360	10	1200	14.0	0.25	230	4.5
RV241K07	240	150	200	395	10	1200	15.0	0.25	210	4.6
RV271K07	270	175	225	455	10	1200	18.0	0.25	185	4.9
RV301K07	300	190	250	500	10	1200	20.0	0.25	165	5.0
RV331K07	330	210	275	550	10	1200	23.0	0.25	150	5.1
RV361K07	360	230	300	595	10	1200	24.0	0.25	140	5.2
RV391K07	390	250	320	650	10	1200	26.0	0.25	130	5.4
RV431K07	430	275	350	710	10	1200	28.0	0.25	115	5.7
RV471K07	470	300	385	775	10	1200	29.0	0.25	105	6.0
RV511K07	510	320	415	845	10	1200	31.0	0.25	100	6.4
RV561K07	560	350	460	925	10	1200	35.0	0.25	90	6.4
RV621K07	620	385	505	1025	10	1200	38.0	0.25	80	7.1
RV681K07	680	420	560	1120	10	1200	42.0	0.25	75	7.4

tmax = maximum part thickness

RV Electrical Specifications – 10 mm

Part Number	V _N 1 mA (V)	V _{RMS} (V)	V _{DC} (V)	V _C (V)	I _C 8/20 us (A)	I _{MAX} 8/20 us (A)	W _{MAX} 10/1000 us (J)	P _{MAX} (W)	C _{TYP} @ 1 kHz (pF)	t _{MAX} (mm)
RV180L10	18	11	14	36	5	500	2.1	0.05	5600	4.6
RV220L10	22	14	18	43	5	500	2.5	0.05	9500	4.7
RV270L10	27	17	22	53	5	500	3.0	0.05	3700	4.8
RV330L10	33	20	26	65	5	500	4.0	0.05	3000	5.0
RV390K10	39	25	31	77	5	500	4.6	0.05	2400	4.9
RV470K10	47	30	38	93	5	500	5.5	0.05	2100	5.0
RV560K10	56	35	45	110	5	500	7.0	0.05	1800	5.1
RV680K10	68	40	56	135	5	500	8.2	0.05	1500	5.3
RV820K10	82	50	65	135	25	2500	12.0	0.40	1200	4.5
RV101K10	100	60	85	165	25	2500	15.0	0.40	1000	4.7
RV121K10	120	75	100	200	25	2500	18.0	0.40	830	4.9
RV151K10	150	95	125	250	25	2500	22.0	0.40	670	5.2
RV181K10	180	115	150	300	25	2500	27.0	0.40	560	4.8
RV201K10	200	130	170	340	25	2500	30.0	0.40	500	4.8
RV221K10	220	140	180	360	25	2500	32.0	0.40	450	4.9
RV241K10	240	150	200	395	25	2500	35.0	0.40	420	5.0
RV271K10	270	175	225	455	25	2500	37.0	0.40	370	5.2
RV301K10	300	190	250	500	25	2500	40.0	0.40	330	5.3
RV331K10	330	210	275	550	25	2500	43.0	0.40	300	5.6
RV361K10	360	230	300	595	25	2500	47.0	0.40	280	5.7
RV391K10	390	250	320	650	25	2500	60.0	0.40	260	5.8
RV431K10	430	275	350	710	25	2500	65.0	0.40	230	6.2
RV471K10	470	300	385	775	25	2500	67.0	0.40	210	6.5
RV511K10	510	320	415	845	25	2500	69.0	0.40	200	6.5
RV561K10	560	350	460	925	25	2500	70.0	0.40	180	6.5
RV621K10	620	385	505	1025	25	2500	72.0	0.40	160	7.1
RV681K10	680	420	560	1120	25	2500	75.0	0.40	150	7.4
RV751K10	750	460	615	1240	25	2500	77.0	0.40	130	7.8
RV781K10	780	485	640	1290	25	2500	80.0	0.40	125	7.9
RV821K10	820	510	670	1355	25	2500	85.0	0.40	120	8.1
RV911K10	910	550	745	1500	25	2500	93.0	0.40	110	8.6
RV102K10	1000	625	825	1650	25	2500	102.0	0.40	100	9.1
RV112K10	1100	680	895	1815	25	2500	115.0	0.40	90	9.7

tmax = maximum part thickness

RV Electrical Specifications – 14 mm

Part Number	V _N (1 mA) (V)	V _{RMS} (V)	V _{DC} (V)	V _C (V)	I _C (8/20 uSec) (A)	I _{MAX} (8/20 uSec) (A)	W _{MAX} (10/1000 uSec) (J)	P _{MAX} (W)	C _{TYP} (@ 1 kHz) (pF)	t _{MAX} (mm)
RV180L14	18	11	14	36	10	1000	4.0	0.10	11100	4.6
RV220L14	22	14	18	43	10	1000	5.0	0.60	9100	4.7
RV270L14	27	17	22	53	10	1000	6.0	0.10	7400	4.8
RV330L14	33	20	26	65	10	1000	7.5	0.60	6100	5.0
RV390K14	39	25	31	77	10	1000	8.6	0.10	5100	4.9
RV470K14	47	30	38	93	10	1000	10.0	0.10	4300	5.0
RV560K14	56	35	45	110	10	1000	11.0	0.10	3600	5.1
RV680K14	68	40	56	135	10	1000	14.0	0.10	2900	5.3
RV820K14	82	50	65	135	50	4500	22.0	0.60	2400	4.5
RV101K14	100	60	85	165	50	4500	28.0	0.60	2000	4.7
RV121K14	120	75	100	200	50	4500	32.0	0.60	1700	4.9
RV151K14	150	95	125	250	50	4500	40.0	0.60	1300	5.2
RV181K14	180	115	150	300	50	4500	50.0	0.60	1100	4.8
RV201K14	200	130	170	340	50	4500	57.0	0.60	1000	4.8
RV221K14	220	140	180	360	50	4500	60.0	0.60	900	4.9
RV241K14	240	150	200	395	50	4500	63.0	0.60	830	5.0
RV271K14	270	175	225	455	50	4500	70.0	0.60	740	5.2
RV301K14	300	190	250	500	50	4500	77.0	0.60	670	5.3
RV331K14	330	210	275	550	50	4500	85.0	0.60	610	5.6
RV361K14	360	230	300	595	50	4500	93.0	0.60	560	5.7
RV391K14	390	250	320	650	50	4500	100.0	0.60	510	5.8
RV431K14	430	275	350	710	50	4500	115.0	0.60	460	6.2
RV471K14	470	300	385	775	50	4500	118.0	0.60	430	6.5
RV511K14	510	320	415	845	50	4500	121.0	0.60	390	6.5
RV561K14	560	350	460	925	50	4500	125.0	0.60	360	6.5
RV621K14	620	385	505	1025	50	4500	128.0	0.60	320	7.1
RV681K14	680	420	560	1120	50	4500	130.0	0.60	290	7.4
RV751K14	750	460	615	1240	50	4500	143.0	0.60	270	7.8
RV781K14	780	485	640	1290	50	4500	148.0	0.60	260	7.9
RV821K14	820	510	670	1355	50	4500	157.0	0.60	240	8.1
RV911K14	910	550	745	1500	50	4500	175.0	0.60	220	8.6
RV102K14	1000	625	825	1650	50	4500	190.0	0.60	200	9.1
RV112K14	1100	680	895	1815	50	4500	213.0	0.60	180	9.7
RV182K14	1800	1000	1465	2970	50	4500	250.0	0.60	130	14.4

tmax = maximum part thickness

RV Electrical Specifications – 20 mm

Part Number	V _N (1 mA) (V)	V _{RMS} (V)	V _{DC} (V)	V _C (V)	I _C (8/20 uSec) (A)	I _{MAX} (8/20 uSec) (A)	W _{MAX} (10/1000 uSec) (J)	P _{MAX} (W)	C _{TYP} (@ 1 kHz) (pF)	t _{MAX} (mm)
RV180K20	18	11	14	36	20	2000	11.0	0.20	28500	5.3
RV220K20	22	14	18	43	20	2000	14.0	0.20	18500	5.4
RV270K20	27	17	22	53	20	2000	16.0	0.20	13000	5.5
RV330K20	33	20	26	65	20	2000	23.0	0.20	11500	5.6
RV390LK0	39	25	31	77	20	2000	26.0	0.20	8500	5.5
RV470K20	47	30	38	93	20	2000	30.0	0.20	7400	5.6
RV560K20	56	35	45	110	20	2000	38.0	0.20	6500	5.7
RV680K20	68	40	56	135	20	2000	41.0	0.20	5800	5.8
RV820K20	82	50	65	135	100	6500	45.0	1.00	4900	4.9
RV101K20	100	60	85	165	100	6500	50.0	1.00	4000	5.1
RV121K20	120	75	100	200	100	6500	55.0	1.00	3300	5.3
RV151K20	150	95	125	250	100	6500	70.0	1.00	2700	5.6
RV181K20	180	115	150	300	100	6500	85.0	1.00	2200	5.2

RV Electrical Specifications – 20 mm (cont.)

Part Number	V _N (1 mA) (V)	V _{RMS} (V)	V _{DC} (V)	V _C (V)	I _C (8/20 uSec) (A)	I _{MAX} (8/20 uSec) (A)	W _{MAX} (10/1000 uSec) (J)	P _{MAX} (W)	C _{TYP} (@ 1 kHz) (pF)	t _{MAX} (mm)
RV201K20	200	130	170	340	100	6500	95.0	1.00	2000	5.2
RV221K20	220	140	180	360	100	6500	100.0	1.00	1800	5.3
RV241K20	240	150	200	395	100	6500	108.0	1.00	1650	5.4
RV271K20	270	175	225	455	100	6500	127.0	1.00	1500	5.6
RV301K20	300	190	250	500	100	6500	136.0	1.00	1300	5.7
RV331K20	330	210	275	550	100	6500	150.0	1.00	1200	6.0
RV361K20	360	230	300	595	100	6500	163.0	1.00	1100	6.2
RV391K20	390	250	320	650	100	6500	180.0	1.00	1000	6.4
RV431K20	430	275	350	710	100	6500	190.0	1.00	930	6.7
RV471K20	470	300	385	775	100	6500	204.0	1.00	850	7.0
RV511K20	510	320	415	845	100	6500	210.0	1.00	780	7.0
RV561K20	560	350	460	925	100	6500	215.0	1.00	710	7.0
RV621K20	620	385	505	1025	100	6500	224.0	1.00	650	7.5
RV681K20	680	420	560	1120	100	6500	230.0	1.00	600	7.8
RV751K20	750	460	615	1240	100	6500	255.0	1.00	530	8.2
RV781K20	780	485	640	1290	100	6500	265.0	1.00	510	8.3
RV821K20	820	510	670	1355	100	6500	282.0	1.00	500	8.5
RV911K20	910	550	745	1500	100	6500	310.0	1.00	440	9.0
RV102K20	1000	625	825	1650	100	6500	342.0	1.00	400	9.5
RV112K20	1100	680	895	1815	100	6500	383.0	1.00	360	10.1
RV182K20	1800	1000	1465	2970	100	6500	625.0	1.00	320	14.8

tmax = maximum part thickness

RV-HE Electrical Specifications – 10 mm

Part Number	V _N (1 mA) (V)	V _{RMS} (V)	V _{DC} (V)	V _C (V)	I _C (8/20 uSec) (A)	I _{MAX} (8/20 uSec) (A)	W _{MAX} (10/1000 uSec) (J)	P _{MAX} (W)	C _{TYP} (@ 1 kHz) (pF)	t _{MAX} (mm)
RV201K10 -HE	200	130	170	340	25	3500	35	0.4	570	5.9
RV221K10 -HE	220	140	180	360	25	3500	39	0.4	520	5.9
RV241K10 -HE	240	150	200	395	25	3500	42	0.4	480	6.0
RV271K10 -HE	270	175	225	455	25	3500	49	0.4	425	6.2
RV301K10 -HE	300	190	250	500	25	3500	54	0.4	380	6.3
RV331K10 -HE	330	210	275	550	25	3500	58	0.4	350	6.6
RV361K10 -HE	360	230	300	595	25	3500	65	0.4	320	6.7
RV391K10 -HE	390	250	320	650	25	3500	70	0.4	295	6.8
RV431K10 -HE	430	275	350	710	25	3500	80	0.4	260	7.2
RV471K10 -HE	470	300	385	775	25	3500	85	0.4	240	7.5
RV511K10 -HE	510	320	415	845	25	3500	90	0.4	220	7.5
RV561K10 -HE	560	350	460	925	25	3500	92	0.4	200	7.5
RV621K10 -HE	620	385	505	1025	25	3500	95	0.4	180	8.1
RV681K10 -HE	680	420	560	1120	25	3500	98	0.4	175	8.4
RV751K10 -HE	750	460	615	1240	25	3500	100	0.4	160	8.8
RV821K10 -HE	820	510	670	1355	25	3500	110	0.4	150	9.1
RV911K10 -HE	910	550	745	1500	25	3500	130	0.4	130	9.6
RV102K10 -HE	1000	625	825	1650	25	3500	140	0.4	120	10.1
RV112K10 -HE	1100	680	895	1815	25	3500	155	0.4	110	10.7

tmax = maximum part thickness

RV-HE Electrical Specifications – 14 mm

Part Number	V _N (1 mA) (V)	V _{RMS} (V)	V _{DC} (V)	V _C (V)	I _C (8/20 uSec) (A)	I _{MAX} (8/20 uSec) (A)	W _{MAX} (10/1000 uSec) (J)	P _{MAX} (W)	C _{TYP} (@ 1 kHz) (pF)	t _{MAX} (mm)
RV201K14 -HE	200	130	170	340	50	6000	70	0.60	970	5.9
RV221K14 -HE	220	140	180	360	50	6000	78	0.60	880	5.9
RV241K14 -HE	240	150	200	395	50	6000	84	0.60	820	6.0
RV271K14 -HE	270	175	225	455	50	6000	99	0.60	720	6.2
RV301K14 -HE	300	190	250	500	50	6000	108	0.60	650	6.3
RV331K14 -HE	330	210	275	550	50	6000	115	0.60	600	6.6
RV361K14 -HE	360	230	300	595	50	6000	130	0.60	550	6.7
RV391K14 -HE	390	250	320	650	50	6000	140	0.60	500	6.8
RV431K14 -HE	430	275	350	710	50	6000	155	0.60	440	7.2
RV471K14 -HE	470	300	385	775	50	6000	175	0.60	400	7.5
RV511K14 -HE	510	320	415	845	50	6000	180	0.60	370	7.5
RV561K14 -HE	560	350	460	925	50	6000	185	0.60	340	7.5
RV621K14 -HE	620	385	505	1025	50	6000	190	0.60	300	8.1
RV681K14 -HE	680	420	560	1120	50	6000	200	0.60	290	8.4
RV751K14 -HE	750	460	615	1240	50	6000	210	0.60	270	8.8
RV821K14 -HE	820	510	670	1355	50	6000	235	0.60	250	9.1
RV911K14 -HE	910	550	745	1500	50	6000	255	0.60	220	9.6
RV102K14 -HE	1000	625	825	1650	50	6000	280	0.60	200	10.1
RV112K14 -HE	1100	680	895	1815	50	6000	310	0.60	180	10.7
RV182K14 -HE	1800	1000	1465	2970	50	6000	335	0.60	110	15.4

tmax = maximum part thickness

RV-HE Electrical Specifications – 20 mm

Part Number	V _N (1 mA) (V)	V _{RMS} (V)	V _{DC} (V)	V _C (V)	I _C (8/20 uSec) (A)	I _{MAX} (8/20 uSec) (A)	W _{MAX} (10/1000 uSec) (J)	P _{MAX} (W)	C _{TYP} (@ 1 kHz) (pF)	t _{MAX} (mm)
RV201K20 -HE	200	130	170	340	100	10000	140	1.00	1900	6.3
RV221K20 -HE	220	140	180	360	100	10000	155	1.00	1700	6.3
RV241K20 -HE	240	150	200	395	100	10000	168	1.00	1500	6.4
RV271K20 -HE	270	175	225	455	100	10000	190	1.00	1400	6.6
RV301K20 -HE	300	190	250	500	100	10000	210	1.00	1300	6.7
RV331K20 -HE	330	210	275	550	100	10000	228	1.00	1200	7.0
RV361K20 -HE	360	230	300	595	100	10000	255	1.00	1000	7.2
RV391K20 -HE	390	250	320	650	100	10000	275	1.00	880	7.4
RV431K20 -HE	430	275	350	710	100	10000	305	1.00	800	7.7
RV471K20 -HE	470	300	385	775	100	10000	350	1.00	700	8.0
RV511K20 -HE	510	320	415	845	100	10000	360	1.00	630	8.0
RV561K20 -HE	560	350	460	925	100	10000	380	1.00	530	8.0
RV621K20 -HE	620	385	505	1025	100	10000	390	1.00	490	8.5
RV681K20 -HE	680	420	560	1120	100	10000	400	1.00	470	8.8
RV751K20 -HE	750	460	615	1240	100	10000	420	1.00	450	9.2
RV821K20 -HE	820	510	670	1355	100	10000	460	1.00	410	9.5
RV911K20 -HE	910	550	745	1500	100	10000	510	1.00	380	10.0
RV102K20 -HE	1000	625	825	1650	100	10000	565	1.00	360	10.5
RV112K20 -HE	1100	680	895	1815	100	10000	620	1.00	340	11.1
RV182K20 -HE	1800	1000	1465	2970	100	10000	990	1.00	300	15.8

tmax = maximum part thickness

RV-HE Electrical Specifications – 25 mm

Part Number	V _N (1 mA) (V)	V _{RMS} (V)	V _{DC} (V)	V _C (V)	I _C (8/20 uSec) (A)	I _{MAX} (8/20 uSec) (A)	W _{MAX} (10/1000 uSec) (J)	P _{MAX} (W)	C _{TYP} (@ 1 kHz) (pF)	t _{MAX} (mm)
RV201K25 -HE	200	130	170	340	150	18000	190	1.2	3200	5.7
RV241K25 -HE	240	150	200	395	150	18000	220	1.2	2650	5.9
RV271K25 -HE	270	175	225	455	150	18000	255	1.2	2400	6.1
RV361K25 -HE	360	230	300	595	150	18000	330	1.2	1750	6.7
RV391K25 -HE	390	250	320	650	150	18000	360	1.2	1600	6.9
RV431K25 -HE	430	275	350	710	150	18000	380	1.2	1500	7.2
RV471K25 -HE	470	300	385	775	150	18000	400	1.2	1400	7.5
RV511K25 -HE	510	320	415	845	150	18000	420	1.2	1250	7.5
RV621K25 -HE	620	385	505	1025	150	18000	450	1.2	1050	8.0
RV681K25 -HE	680	420	560	1120	150	18000	460	1.2	950	8.3
RV751K25 -HE	750	460	615	1240	150	18000	510	1.2	850	8.7
RV781K25 -HE	780	485	640	1290	150	18000	530	1.2	800	8.8
RV821K25 -HE	820	510	670	1355	150	18000	570	1.2	750	8.6
RV911K25 -HE	910	550	745	1500	150	18000	620	1.2	700	9.5
RV102K25 -HE	1000	625	825	1650	150	18000	685	1.2	650	10.0
RV122K25 -HE	1200	750	990	1980	150	18000	792	1.2	550	11.0

tmax = maximum part thickness

Performance Characteristics

Test	Test Method	Specification														
Varistor Voltage (Vn)	The voltage between two terminals with the specified measuring current 1mA DC applied is called V 1mA. The measurement shall be made as fast as possible to avoid heat effect.	To meet the specified value.														
Maximum Allowable Voltage (Vrms and Vdc)	The maximum sinusoidal RMS voltage or maximum DC voltage that can be applied continuously in the specified environmental temperature range.															
Clamping Voltage (Max.) (Vc)	The maximum voltage between two terminal with the specified standard impulse current (8/20 us) illustrated below applied.															
Maximum Peak Current (Withstanding Surge Current) (Imax)	The maximum current within the varistor voltage change of ± 10% with the standard impulse current (8/20 us) applied one time.	Δ VcmA / VcmA ≤ ± 10% No damage.														
Maximum Energy (Joule) (Wmax)	The maximum energy within the varistor voltage change of ± 10% when one impulse of 2 ms or 10/1000 us is applied.	To meet the specified value.														
Withstanding Voltage (Body Insulation)	The specified voltage shall be applied both terminals of the specimen connected together and metal foil closely wrapped round its body for 1 minute. Electrical breakdown shall be examined. Test voltage: 2500 AC	No breakdown														
Robustness of Terminations (Tensile)	After gradually applying the force specified below and keeping the unit fixed for ten seconds, the terminal shall be visually examined for any damage. <table border="1" style="margin-left: auto; margin-right: auto;"> <thead> <tr> <th colspan="2">Terminal Diameter</th> <th rowspan="2">Force</th> </tr> <tr> <th>Inches</th> <th>mm</th> </tr> </thead> <tbody> <tr> <td>Φ 0.024</td> <td>Φ 0.6</td> <td>9.8N (1 kg)</td> </tr> <tr> <td>Φ 0.031</td> <td>Φ 0.8</td> <td>9.8N (1 kg)</td> </tr> <tr> <td>Φ 0.039</td> <td>Φ 1</td> <td>19.6N (2 kg)</td> </tr> </tbody> </table>	Terminal Diameter		Force	Inches	mm	Φ 0.024	Φ 0.6	9.8N (1 kg)	Φ 0.031	Φ 0.8	9.8N (1 kg)	Φ 0.039	Φ 1	19.6N (2 kg)	No visible damage.
Terminal Diameter		Force														
Inches	mm															
Φ 0.024	Φ 0.6	9.8N (1 kg)														
Φ 0.031	Φ 0.8	9.8N (1 kg)														
Φ 0.039	Φ 1	19.6N (2 kg)														

Performance Characteristics (cont.)																	
Test	Test Method	Specification															
Robustness of Terminations (Bending)	<p>The unit shall be secured with its terminal kept vertical and the force specified below be applied in the axial direction. The terminal shall gradually be bent by 90° in one direction, then 90° in the opposite direction and again back to the original position. The damage of the terminal shall be visually examined.</p> <table border="1"> <thead> <tr> <th colspan="2">Terminal Diameter</th> <th rowspan="2">Force</th> </tr> <tr> <th>Inches</th> <th>mm</th> </tr> </thead> <tbody> <tr> <td>Φ 0.024</td> <td>Φ 0.6</td> <td>4.9N (0.5 kg)</td> </tr> <tr> <td>Φ 0.031</td> <td>Φ 0.8</td> <td>4.9N (0.5 kg)</td> </tr> <tr> <td>Φ 0.039</td> <td>Φ 1</td> <td>9.8N (1 kg)</td> </tr> </tbody> </table>	Terminal Diameter		Force	Inches	mm	Φ 0.024	Φ 0.6	4.9N (0.5 kg)	Φ 0.031	Φ 0.8	4.9N (0.5 kg)	Φ 0.039	Φ 1	9.8N (1 kg)	No visible damage.	
Terminal Diameter		Force															
Inches	mm																
Φ 0.024	Φ 0.6	4.9N (0.5 kg)															
Φ 0.031	Φ 0.8	4.9N (0.5 kg)															
Φ 0.039	Φ 1	9.8N (1 kg)															
Solderability	After dipping the terminals to a depth of approximately 3mm from the body in a soldering bat of 235°C ± 5°C for 2 ± 0.5 seconds. The terminal shall be visually examined.	Approximately 95% of the terminals shall be covered with solder uniformly.															
Resistance to Soldering Heat	After each lead shall be dipped into a solder a bath having a temperature 260°C ± 5°C to a point 2 to 2.5 mm from the body of the unit. Using shielding board (t = 1.5 mm) be held there for specified time 10 ± 1 seconds and then be stored at room temperature and humidity for 1 to 2 hours. The change of Vc and mechanical damages are examined.	Δ VcmA / VcmA ≤ ± 5% No visible damage.															
Vibration Resistance	The varistor should be soldered to the supporting lead wire and vibrated at a frequency range of 10 to 55 Hz, 15 mm. In total amplitude with about one minute rate of vibration charge from 10 Hz to 55 Hz and back to 10 Hz. Apply for a total of 6 hours, 2 hours each in 3 mutually perpendicular directions.	Δ VcmA / VcmA ≤ ± 5% No visible damage.															
Temperature Coefficient of Varistor Voltage	<p>Temperature Coefficient of Varistor Voltage</p> $\frac{Vc1 - Vc2}{Vc2} \times \frac{1}{60} \times 100\%$ <p>Vc1 = 85°C Vc2 = 25°C</p>	± 0.05%/°C max															
High Temperature Storage Dry Heat	The specimen shall be subjected to 125°C ± 2°C for 1000 hours in a thermostatic bath without load and then stored at room temperature and humidity for 1 to 2 hours. Thereafter, the change of Vc shall be measured.	Δ VcmA / VcmA ≤ ± 10% No visible damage.															
Damp Heat/Humidity Steady State	The specimen shall be subjected to 40°C ± 2°C, 90 to 95% RH for 1000 hours without load and then stored at room temperature and humidity for 1 to 2 hours. Thereafter, the change of Vc shall be measured.	Δ VcmA / VcmA ≤ ± 5% No visible damage.															
Temperature Cycle	<p>The temperature cycle shown below shall be repeated five times and then stored at room temperature and humidity for 1 to 2 hours. The change of Vc and mechanical damage shall be examined.</p> <table border="1"> <thead> <tr> <th>Step</th> <th>Temperature (°C)</th> <th>Period (minutes)</th> </tr> </thead> <tbody> <tr> <td>1</td> <td>-40 ± 3</td> <td>30 ± 3</td> </tr> <tr> <td>2</td> <td>Room temperature</td> <td>15 ± 3</td> </tr> <tr> <td>3</td> <td>125 ± 2</td> <td>30 ± 3</td> </tr> <tr> <td>4</td> <td>Room temperature</td> <td>15 ± 3</td> </tr> </tbody> </table>	Step	Temperature (°C)	Period (minutes)	1	-40 ± 3	30 ± 3	2	Room temperature	15 ± 3	3	125 ± 2	30 ± 3	4	Room temperature	15 ± 3	Δ VcmA / VcmA ≤ ± 5% No visible damage.
Step	Temperature (°C)	Period (minutes)															
1	-40 ± 3	30 ± 3															
2	Room temperature	15 ± 3															
3	125 ± 2	30 ± 3															
4	Room temperature	15 ± 3															

Performance Characteristics (cont.)		
Characteristics	Test Method	Specification
High Temperature Load Dry Heat Load	After being continuously applied the Maximum Allowable Voltage at $85^{\circ}\text{C} \pm 2^{\circ}\text{C}$ for 1000 hours, the specimen shall be stored at room temperature and humidity for 1 to 2 hours. Thereafter, the change of Vc shall be examined.	$\Delta V_{cmA} / V_{cmA} \leq \pm 10\%$ No visible damage.
Damp Heat Load Humidity Load	The specimen shall be subjected to $40^{\circ}\text{C} \pm 2^{\circ}\text{C}$, 90 to 95% RH and the Maximum Allowable Voltage for 1000 hours and then stored at room temperature and humidity for 1 to 2 hours. Thereafter, the change of Vc shall be measured.	$\Delta V_{cmA} / V_{cmA} \leq \pm 10\%$ No visible damage.
Pulse Current (IEC60950-1:2013, Annex Q)	Applied the output open voltage and short-circuit current for combination wave of 6 KV / 3 KA separately. The test consists of 10 positive pulses or 10 negative pulses, and 1 minute spacing time.	$\Delta V_{cmA} / V_{cmA} \leq \pm 10\%$ No visible damage.

Environment Test		
Temperature	Humidity	Atmospheric Pressure
$15^{\circ}\text{C} \sim 35^{\circ}\text{C}$	45% ~ 85%	86 kPa ~ 105 kPa

Unless otherwise specified, test and measurement shall be made at standard conditions.

RV - Mechanical Specifications							
Straight Long No code		Straight Short Code = S		Vertical Crimped Code = V		Outside Crimped Long Code = C	Outside Crimped Short Code = D
Disc Size	5 mm	7 mm	10 mm	14 mm	20 mm	Unit	
D max	0.295 7.50	0.354 9.00	0.551 14.00	0.669 17.00	0.984 25.00	inches mm	
d	0.024 0.60	0.024 0.60	0.031 0.80	0.031 0.80	0.031 0.80	inches mm	
F	0.197 ± 0.039 5.00 ± 1.00	0.197 ± 0.039 5.00 ± 1.00	0.295 ± 0.039 7.50 ± 1.00	0.295 ± 0.039 7.50 ± 1.00	0.394 ± 0.039 10.00 ± 1.00	inches mm	
P max. ⁽¹⁾	0.118 3.00				0.157 4.00	inches mm	
H2 max.	0.189 4.80						inches mm
L ⁽²⁾ (bulk only)	0.709 18.00						inches mm
T max	Refer to Electrical Specification chart above						

Notes: (1) 0.118" (3 mm) Suitable for straight lead

(2) Lead length for short lead options can be customized to customer requirements

RV-HE Mechanical Specifications					
Straight Long No code	Straight Short Code = S	Vertical Crimped Code = V	Outside Crimped Long Code = C	Outside Crimped Short Code = D	
Disc Size	10 mm	14 mm	20 mm	25 mm	Unit
D max	0.591 15.00	0.669 17.00	0.984 25.00	1.181 30.00	inches mm
d	0.031 0.80	0.031 0.80	0.039 1.00	0.039 1.00	inches mm
F	0.295 ± 0.039 7.50 ± 1.00	0.295 ± 0.039 7.50 ± 1.00	0.394 ± 0.039 10.00 ± 1.00	0.394 ± 0.039 10.00 ± 1.00	inches mm
P ⁽¹⁾	0.118 max. 3.00 max.			0.157 max. 4.00 max.	inches mm
H2 max.	0.189 4.80				inches mm
L ⁽²⁾ (bulk only)	0.787 20.00				inches mm
T max	Refer to Electrical Specification				

Notes: (1) 0.118" (3 mm) Suitable for straight lead
(2) Lead length for short lead options can be customized to customer requirements

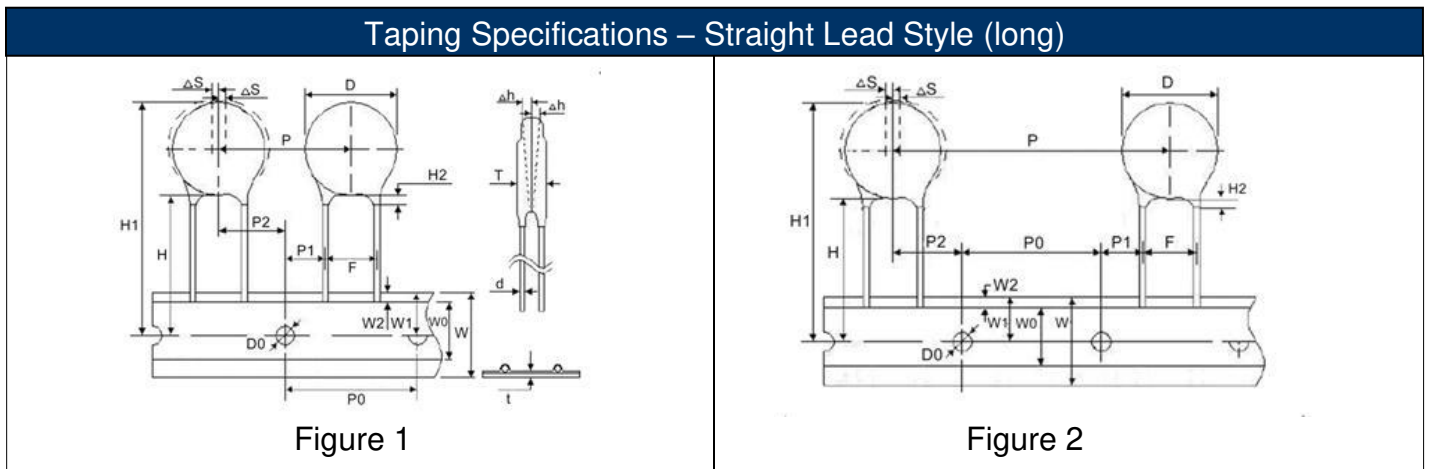

Symbol	Item	5 mm / 7 mm	10 mm	14 mm	Unit
		Fig.1	Fig.1	Fig.2	
F	Lead to lead distance	0.197 ± 0.020 5.00 ± 0.50	0.295 ± 0.020 7.50 ± 0.50	0.295 ± 0.020 7.50 ± 0.50	inches mm
P	Pitch of component	0.500 ± 0.039 12.70 ± 1.00	0.500 ± 0.039 12.70 ± 1.00	1.000 ± 0.039 25.40 ± 1.00	inches mm
P0	Feed hole pitch	0.500 ± 0.012 12.70 ± 0.30	0.500 ± 0.012 12.70 ± 0.30	0.500 ± 0.012 12.70 ± 0.30	inches mm
P1	Feed hole center to lead center	0.152 ± 0.028 3.85 ± 0.70	0.102 ± 0.028 2.60 ± 0.70	0.102 ± 0.028 2.60 ± 0.70	inches mm
P2	Feed hole center to body center	0.250 ± 0.051 6.35 ± 1.30	0.250 ± 0.051 6.35 ± 1.30	0.250 ± 0.051 6.35 ± 1.30	inches mm

Taping Specifications – Straight Lead Style (long) (cont.)

Symbol	Item	5 mm / 7 mm	10 mm	14 mm	Unit
		Fig.1	Fig.1	Fig.2	
Δs	Component alignment R-L	0.000 ± 0.079 0.00 ± 2.00	0.000 ± 0.079 0.00 ± 2.00	0.000 ± 0.157 0.00 ± 4.00	inches mm
W	Tape width	0.709 ± 0.039 18.00 ± 1.00	0.709 ± 0.039 18.00 ± 1.00	0.709 ± 0.039 18.00 ± 1.00	inches mm
W0	Hole down tape width	0.315 min 8.00 min	0.315 min 8.00 min	0.315 min 8.00 min	inches mm
W1	Hole position	0.354 ± 0.020 9.00 ± 0.50	0.354 ± 0.020 9.00 ± 0.50	0.354 ± 0.020 9.00 ± 0.50	inches mm
W2	Hole down tape position	0.197 max 5.00 max	0.197 max 5.00 max	0.197 max 5.00 max	inches mm
H	Height of component from tape center	0.787 ± 0.079 20.00 ± 2.00	0.787 ± 0.079 20.00 ± 2.00	0.787 ± 0.079 20.00 ± 2.00	inches mm
H1	Component height	1.142 max 29.00 max	1.339 max 34.00 max	1.457 max 37.00 max	inches mm
H2	Dip length	0.118 max 3.00 max	0.118 max 3.00 max	0.118 max 3.00 max	inches mm
D0	Feed hole diameter	0.157 ± 0.008 4.00 ± 0.20	0.157 ± 0.008 4.00 ± 0.20	0.157 ± 0.008 4.00 ± 0.20	inches mm
t	Total tape thickness	0.024 ± 0.012 0.60 ± 0.30	0.024 ± 0.012 0.60 ± 0.30	0.024 ± 0.012 0.60 ± 0.30	inches mm
d	Wire diameter	0.024 ± 0.004 0.60 ± 0.10	0.031 ± 0.004 0.80 ± 0.10	0.031 ± 0.004 0.80 ± 0.10	inches mm
D	Max diameter	Refer to Mechanical Specifications			
T	Max thickness	Refer to Electrical Specifications			

Taping Specifications – Outside Crimped Lead Style (long)

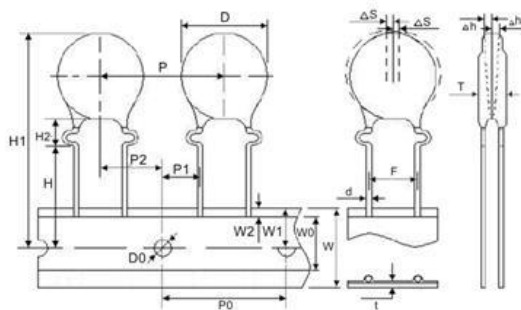

Figure 1

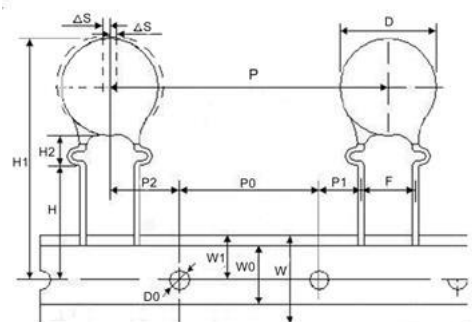

Figure 2

Symbol	Item	5 mm / 7 mm	10 mm	14 mm	Unit
		Fig.1	Fig.1	Fig.2	
F	Lead to lead distance	0.197 ± 0.020 5.00 ± 0.50	0.295 ± 0.020 7.50 ± 0.50	0.295 ± 0.020 7.50 ± 0.50	inches mm
P	Pitch of component	0.500 ± 0.039 12.70 ± 1.00	0.500 ± 0.039 12.70 ± 1.00	1.000 ± 0.039 25.40 ± 1.00	inches mm
P0	Feed hole pitch	0.500 ± 0.012 12.70 ± 0.30	0.500 ± 0.012 12.70 ± 0.30	0.500 ± 0.012 12.70 ± 0.30	inches mm
P1	Feed hole center to lead center	0.152 ± 0.028 3.85 ± 0.70	0.102 ± 0.028 2.60 ± 0.70	0.102 ± 0.028 2.60 ± 0.70	inches mm
P2	Feed hole center to body center	0.250 ± 0.051 6.35 ± 1.30	0.250 ± 0.051 6.35 ± 1.30	0.250 ± 0.051 6.35 ± 1.30	inches mm

Taping Specifications – Outside Crimped Lead Style (long) (cont.)

Symbol	Item	5 mm / 7 mm	10 mm	14 mm	Unit
		Fig.1	Fig.1	Fig.2	
Δs	Component alignment R-L	0.000 ± 0.079 0.00 ± 2.00	0.000 ± 0.079 0.00 ± 2.00	0.000 ± 0.157 0.00 ± 4.00	inches mm
W	Tape width	0.709 ± 0.039 18.00 ± 1.00	0.709 ± 0.039 18.00 ± 1.00	0.709 ± 0.039 18.00 ± 1.00	inches mm
W0	Hole down tape width	0.315 min 8.00 min	0.315 min 8.00 min	0.315 min 8.00 min	inches mm
W1	Hole position	0.354 ± 0.020 9.00 ± 0.50	0.354 ± 0.020 9.00 ± 0.50	0.354 ± 0.020 9.00 ± 0.50	inches mm
W2	Hole down tape position	0.197 max 5.00 max	0.197 max 5.00 max	0.197 max 5.00 max	inches mm
H	Height of component from tape center	0.630 ± 0.079 16.00 ± 2.00	0.630 ± 0.079 16.00 ± 2.00	0.630 ± 0.079 16.00 ± 2.00	inches mm
H1	Component height	1.142 max 29.00 max	1.339 max 34.00 max	1.457 max 37.00 max	inches mm
H2	Dip length	0.189 max 4.80 max	0.189 max 4.80 max	0.189 max 4.80 max	inches mm
D0	Feed hole diameter	0.157 ± 0.008 4.00 ± 0.20	0.157 ± 0.008 4.00 ± 0.20	0.157 ± 0.008 4.00 ± 0.20	inches mm
t	Total tape thickness	0.024 ± 0.012 0.60 ± 0.30	0.024 ± 0.012 0.60 ± 0.30	0.024 ± 0.012 0.60 ± 0.30	inches mm
d	Wire diameter	0.024 ± 0.004 0.60 ± 0.10	0.031 ± 0.004 0.80 ± 0.10	0.031 ± 0.004 0.80 ± 0.10	inches mm
D	Max diameter	Refer to Mechanical Specifications			
T	Max thickness	Refer to Electrical Specifications			

Taping Specifications – Vertical Crimped Lead Style

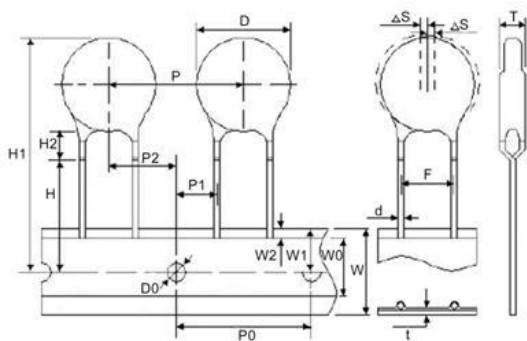

Figure 1

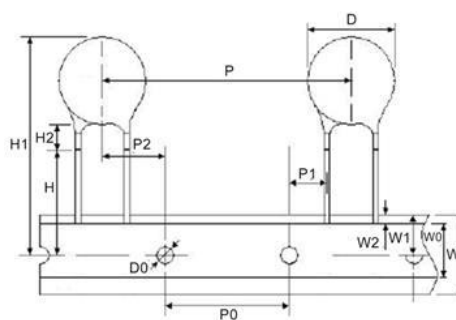

Figure 2

Symbol	Item	5 mm / 7 mm	10 mm	14 mm	Unit
		Fig.1	Fig.1	Fig.2	
F	Lead to lead distance	0.197 ± 0.020 5.00 ± 0.50	0.295 ± 0.020 7.50 ± 0.50	0.295 ± 0.020 7.50 ± 0.50	inches mm
P	Pitch of component	0.500 ± 0.039 12.70 ± 1.00	0.500 ± 0.039 12.70 ± 1.00	1.000 ± 0.039 25.40 ± 1.00	inches mm
P0	Feed hole pitch	0.500 ± 0.012 12.70 ± 0.30	0.500 ± 0.012 12.70 ± 0.30	0.500 ± 0.012 12.70 ± 0.30	inches mm
P1	Feed hole center to lead center	0.152 ± 0.028 3.85 ± 0.70	0.102 ± 0.028 2.60 ± 0.70	0.102 ± 0.028 2.60 ± 0.70	inches mm
P2	Feed hole center to body center	0.250 ± 0.051 6.35 ± 1.30	0.250 ± 0.051 6.35 ± 1.30	0.250 ± 0.051 6.35 ± 1.30	inches mm

Taping Specifications – Vertical Crimped Lead Style (cont.)

Symbol	Item	5 mm / 7 mm	10 mm	14 mm	Unit
		Fig.1	Fig.1	Fig.2	
Δs	Component alignment R-L	0.000 ± 0.079 0.00 ± 2.00	0.000 ± 0.079 0.00 ± 2.00	0.000 ± 0.157 0.00 ± 4.00	inches mm
W	Tape width	0.709 ± 0.039 18.00 ± 1.00	0.709 ± 0.039 18.00 ± 1.00	0.709 ± 0.039 18.00 ± 1.00	inches mm
W0	Hole down tape width	0.315 min 8.00 min	0.315 min 8.00 min	0.315 min 8.00 min	inches mm
W1	Hole position	0.354 ± 0.020 9.00 ± 0.50	0.354 ± 0.020 9.00 ± 0.50	0.354 ± 0.020 9.00 ± 0.50	inches mm
W2	Hole down tape position	0.197 max 5.00 max	0.197 max 5.00 max	0.197 max 5.00 max	inches mm
H	Height of component from tape center	0.630 ± 0.079 16.00 ± 2.00	0.630 ± 0.079 16.00 ± 2.00	0.630 ± 0.079 16.00 ± 2.00	inches mm
H1	Component height	1.142 max 29.00 max	1.339 max 34.00 max	1.457 max 37.00 max	inches mm
H2	Dip length	0.189 max 4.80 max	0.189 max 4.80 max	0.189 max 4.80 max	inches mm
D0	Feed hole diameter	0.157 ± 0.008 4.00 ± 0.20	0.157 ± 0.008 4.00 ± 0.20	0.157 ± 0.008 4.00 ± 0.20	inches mm
t	Total tape thickness	0.024 ± 0.012 0.60 ± 0.30	0.024 ± 0.012 0.60 ± 0.30	0.024 ± 0.012 0.60 ± 0.30	inches mm
d	Wire diameter	0.024 ± 0.004 0.60 ± 0.10	0.031 ± 0.004 0.80 ± 0.10	0.031 ± 0.004 0.80 ± 0.10	inches mm
D	Max diameter	Refer to Mechanical Specifications			
T	Max thickness	Refer to Electrical Specifications			

Component Structure

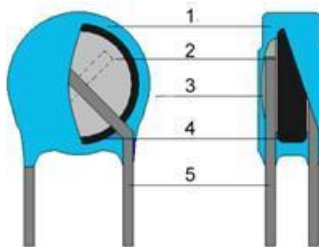

Ref. No.	Part	Name	Material	CAS No.	Component Percentage	Material Percentage
1	Coating	Epoxy Resin UL94-V0	Epoxy resin	25036-25-3	32%	50%
			SiO2	60676-86-0		45%
			Sb2o3	1309-64-4		5%
2	Electrode	Silver	Ag	7440-22-4	4%	100%
3	Solder	Alloy Tin	Sn	7440-31-5	10%	96.50%
			Ag	7440-22-4		3%
			Cu	7440-50-8		0.50%
4	Dielectric	ZnO	ZnO	1314-13-2	38%	100%
5	Lead Wire	CP	Fe	7439-89-6	16%	87%
			Cu	7440-50-8		10%
			Sn	7440-31-5		3%

Lead Wire Structure

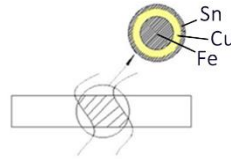

Marking Explanation

Type	Pattern	Explanation
RV		Product Series Diameter / Lead Forming / Voltage / Tolerance Safety standards
RV-HE		Product Series Diameter/ Lead Forming / Voltage / Tolerance / High Energy Safety standards

Safety Standard Approvals

Safety Standard	Recognized No.	Range	Standard No.
UL	E476752	05mm (180K~561K) 07mm (180K~681K) 10mm (180L~112K) 14mm (180L~182K) 20mm (180K~182K)	UL1449 other type

Wave Soldering Condition

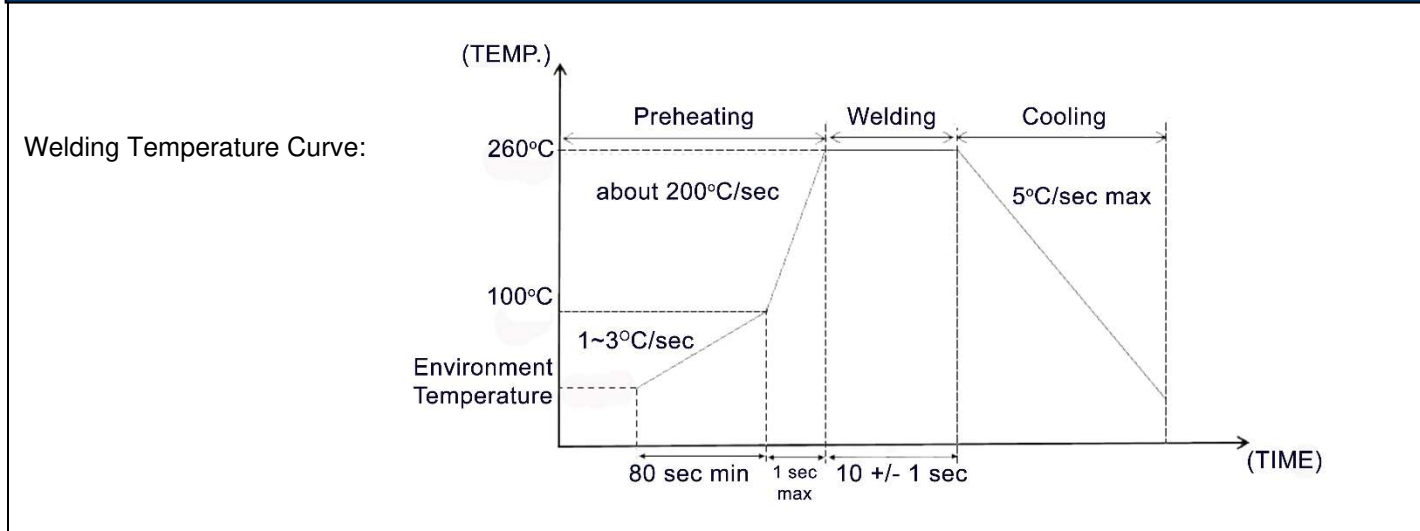

Soldering Iron Welding Specifications	
Solder Iron Temperature	350°C ± 10°C
Welding Time	3 seconds max
Welding Position	2 mm min
Distance Coating Position	

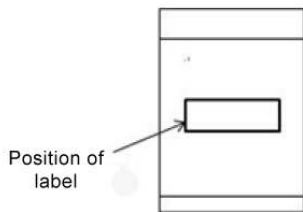
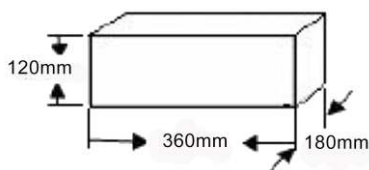
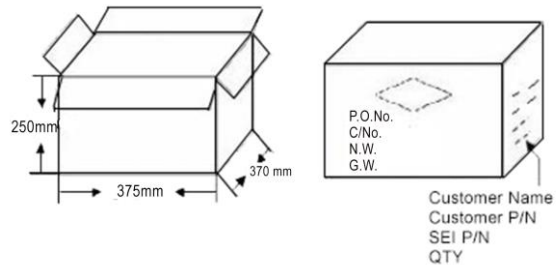
Packaging Specifications		
Inner Bag	Inner Box	Outer Box
 <p>Position of label</p>		

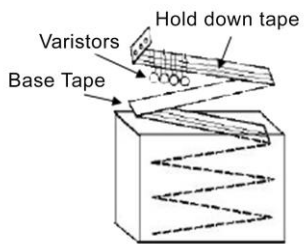
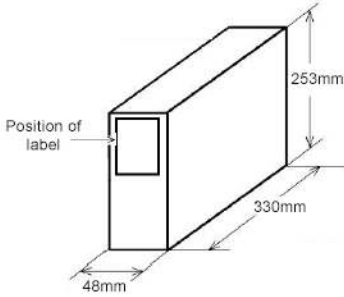
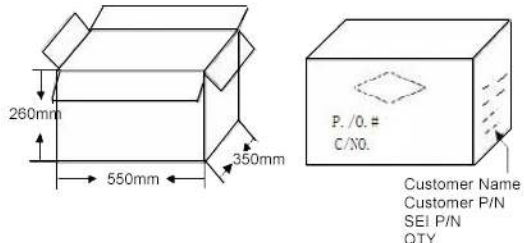
Packing Specifications - Ammo		
Tape Folding	Inner Box	Outer Box
		

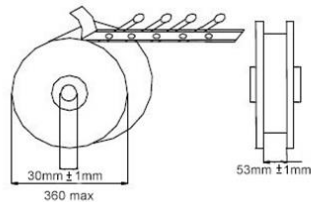
Reel Specifications

Packaging Specifications – Bulk				
Type	VN (1 mA)		Bulk Package Quantity (*)	How to Order Code
	RV	RV-HE		
5 mm	All		1000	B
7 mm			1000	
10 mm			500	
14 mm			250	
20 mm			100	
25 mm	NA	200V - 360V	250	
		390V - 680V	200	
		750V - 1200V	150	

(*) Contact Stackpole Electronics for MOQ

Packaging Specifications – Ammo				
Type	VN (1 mA)		Ammo Package Quantity (*)	How to Order Code
	RV	RV-HE		
5 mm	All		1000	A
7 mm			1000	
10 mm			500	
14 mm			500	

(*) Contact Stackpole Electronics for MOQ

Packaging Specifications – Tape and Reel				
Type	VN (1 mA)		Reel Package Quantity (*)	How to Order Code
	RV	RV-HE		
5 mm	All		1000	T
7 mm				
10 mm	≤ 510V	NA	1000	T
	560V - 910V	≤ 470V	750	
	1000V - 1800V	> 470V	500	D
14 mm	≤ 390V		750	T
	> 390V		500	D

(*) Contact Stackpole Electronics for MOQ

Storage Specifications	
Storage Temperature	-10°C ~ 40°C
Relative Humidity	≤ 75% RH
Storage Period	1 year
Operation Temperature Range	-40°C ~ 85°C
Do not use this product in corrosive gases or in direct sunlight environment preservation.	

Impulse Lifetime Ratings

2 times: 5 minutes interval
 Up to 10 times: 2 minutes interval
 Up to 10^6 times: 10 seconds interval

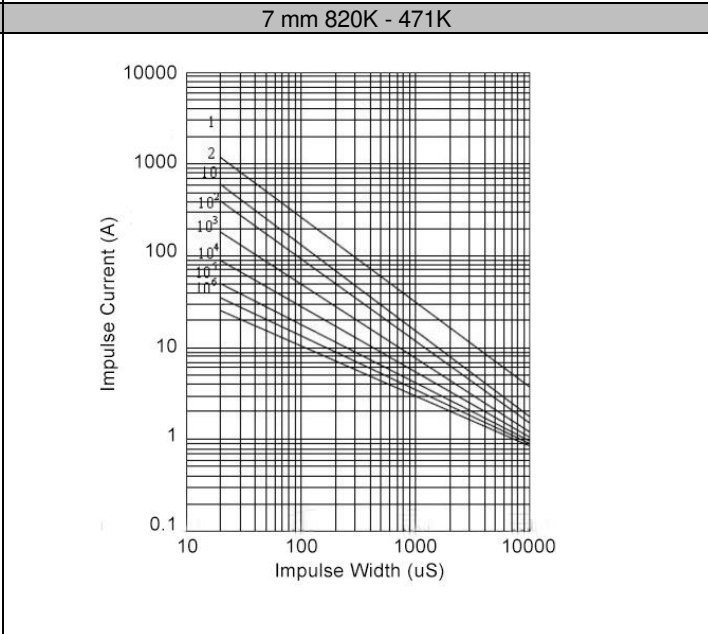
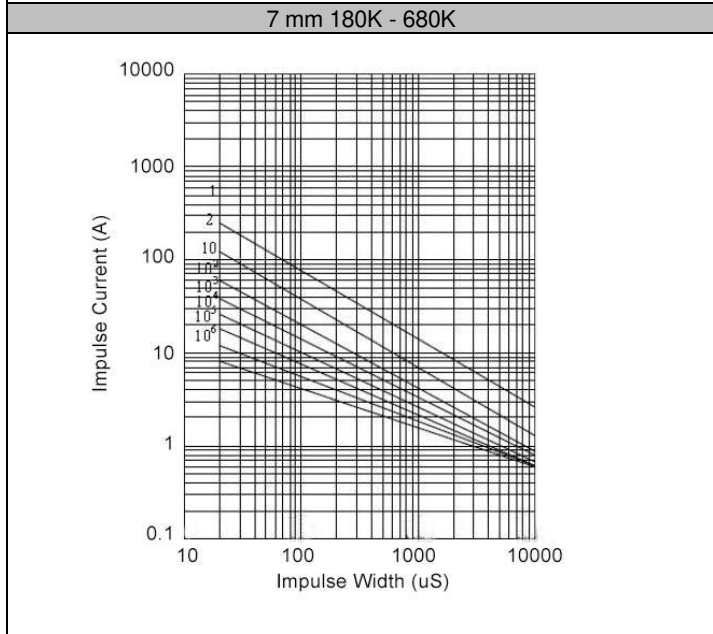
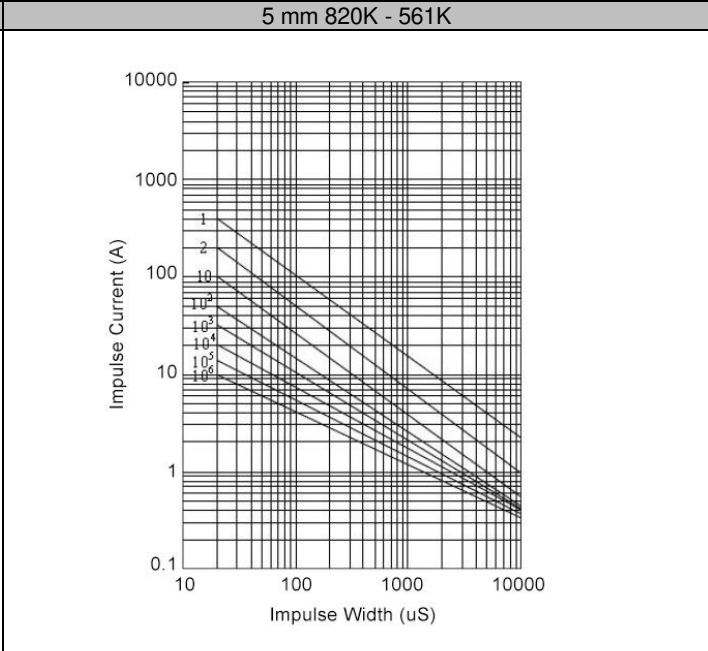
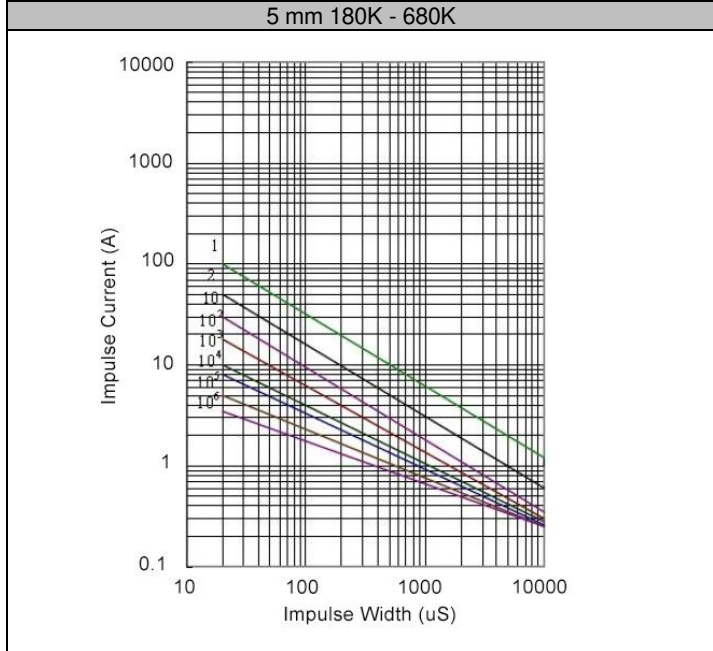

Impulse Lifetime Ratings

2 times: 5 minutes interval
 Up to 10 times: 2 minutes interval
 Up to 10^6 times: 10 seconds interval

7 mm 511K - 681K

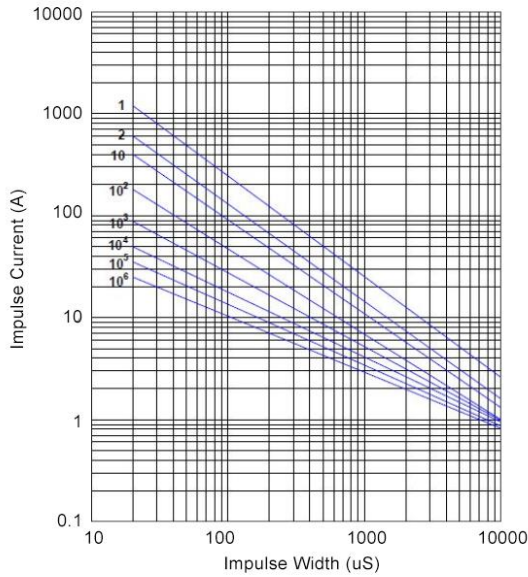

10 mm 180L - 680K

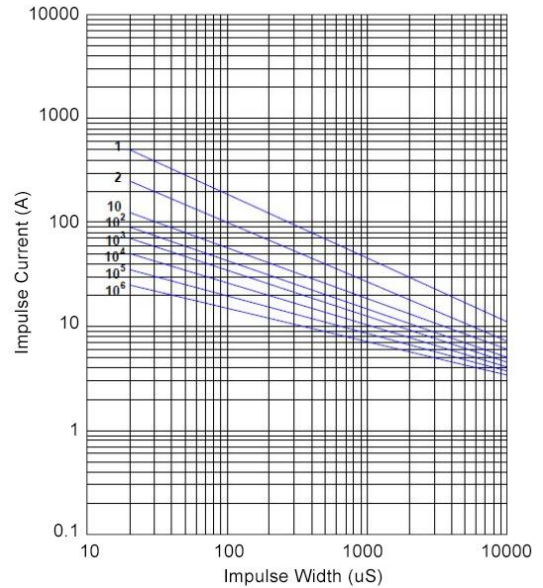

10 mm 820K - 751K

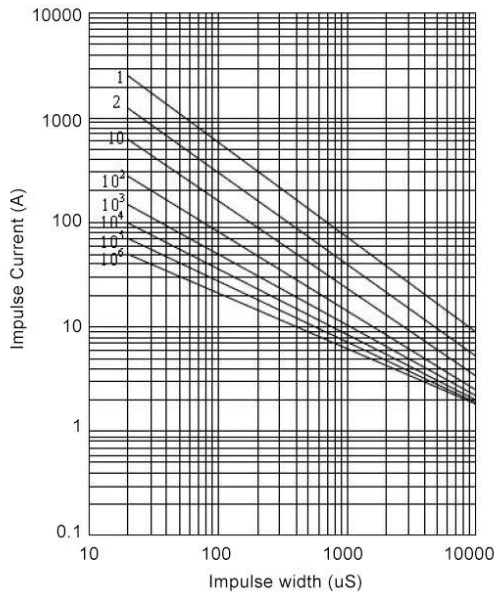

10 mm 821K - 112K

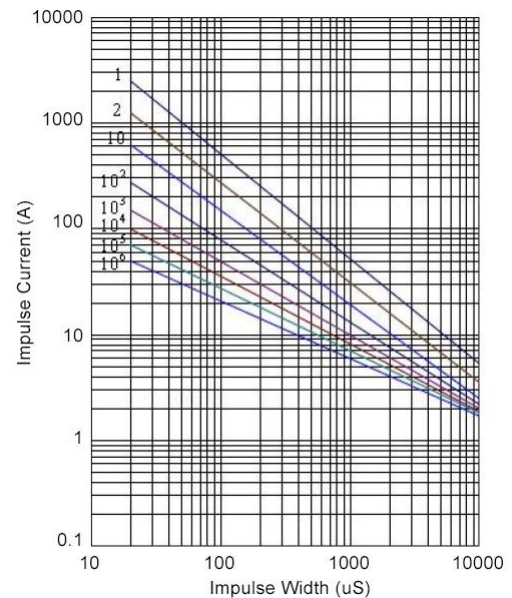

Impulse Lifetime Ratings

2 times: 5 minutes interval
 Up to 10 times: 2 minutes interval
 Up to 10^6 times: 10 seconds interval

14 mm 180L - 680K

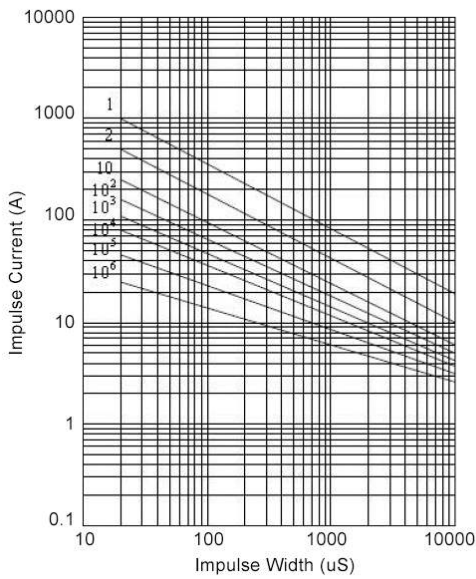

14 mm 820K - 751K

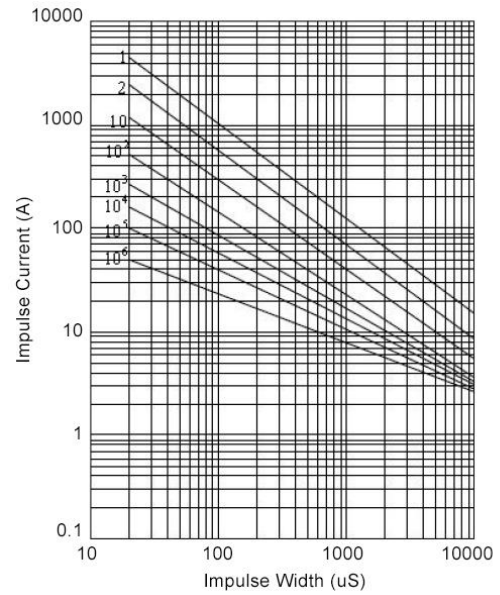

14 mm 821K - 182K

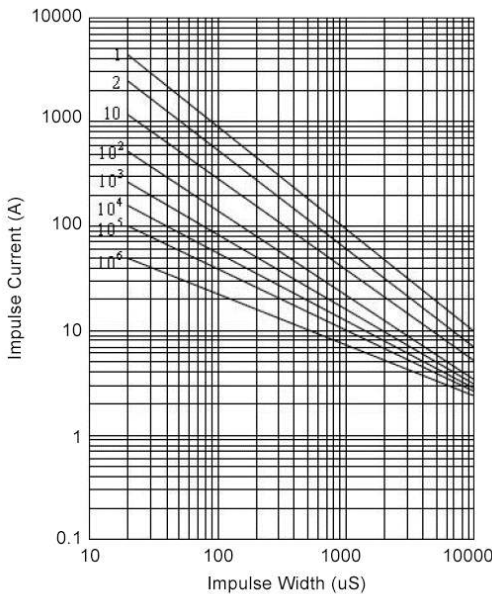

20 mm 180K - 680K

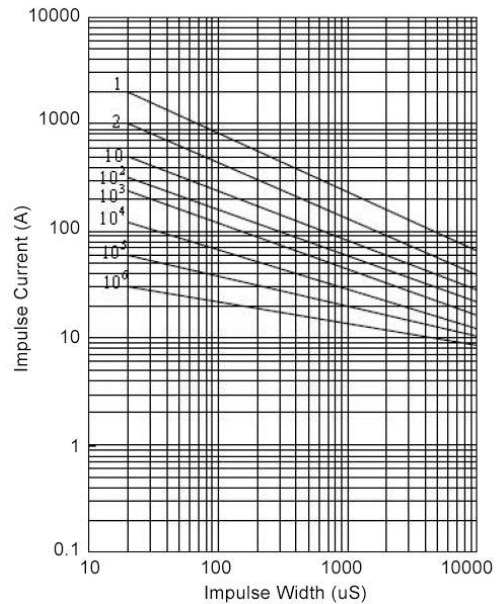

Impulse Lifetime Ratings

2 times: 5 minutes interval
 Up to 10 times: 2 minutes interval
 Up to 10^6 times: 10 seconds interval

20 mm 820K - 751K

20 mm 821K - 182K

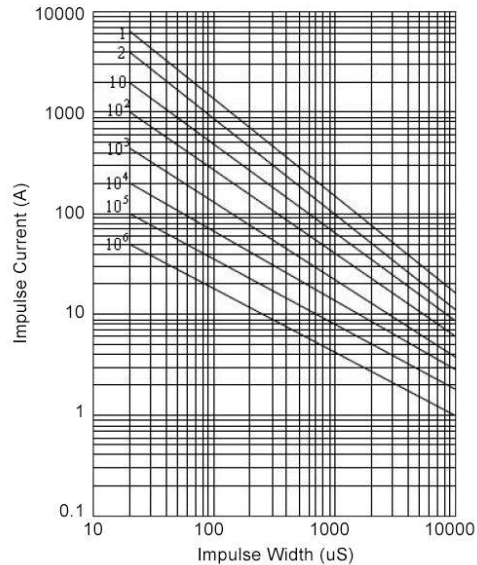
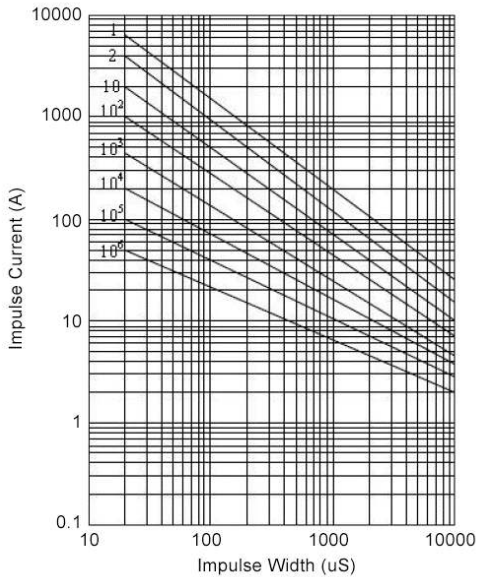

Voltage Curve – 5 mm 180K-680K

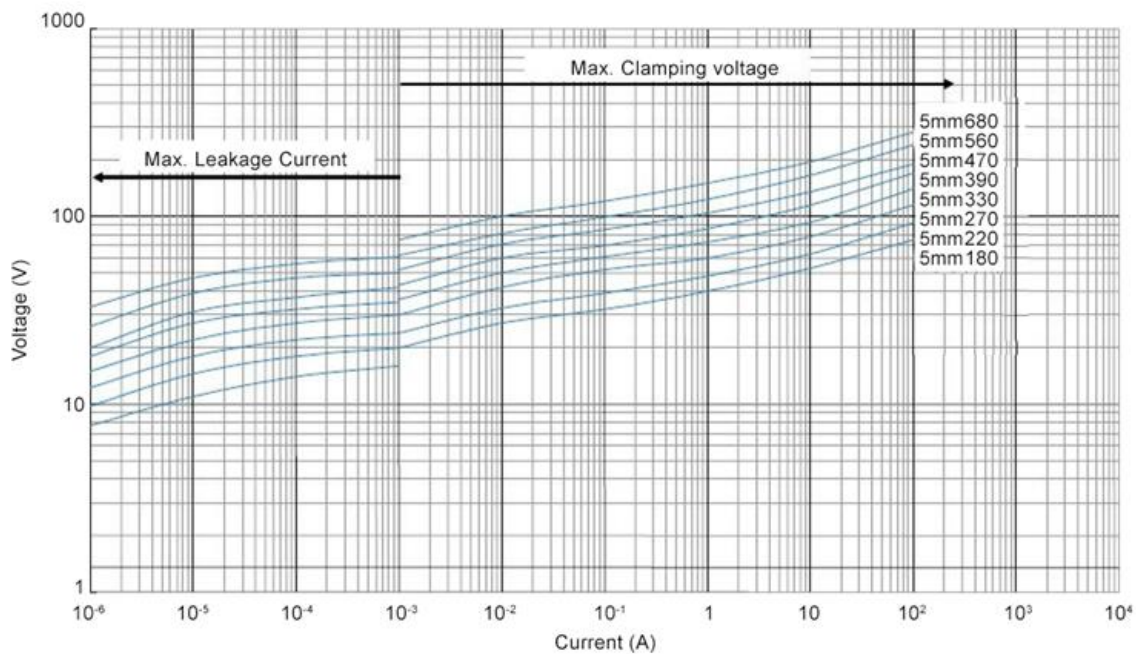

Voltage Curve – 5 mm 820K-751K

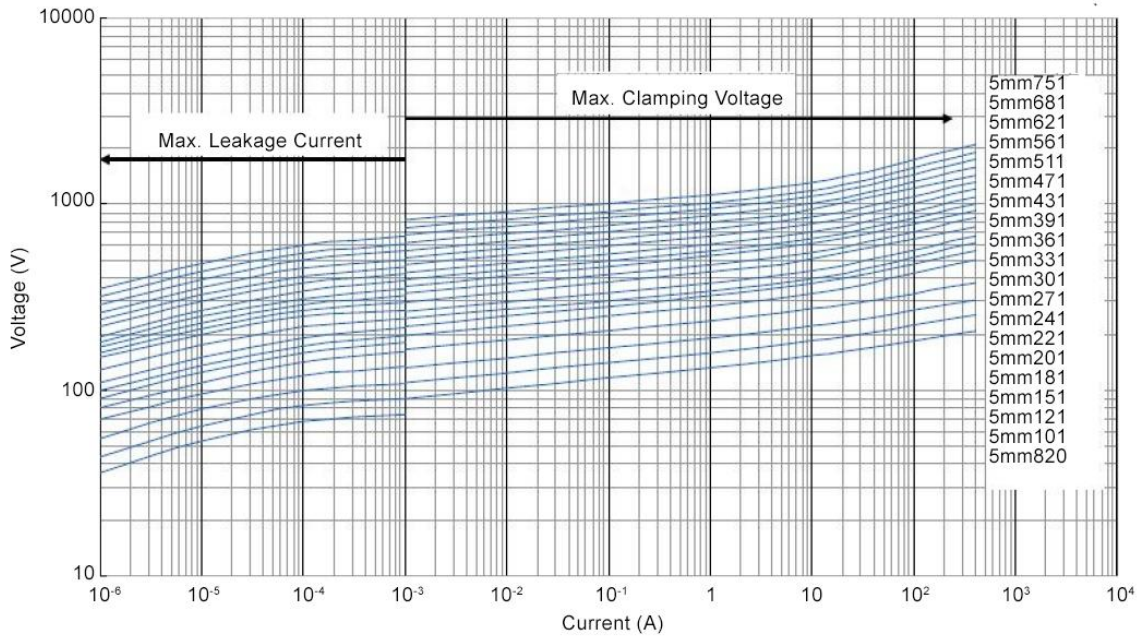

Voltage Curve – 7 mm 180K-680K

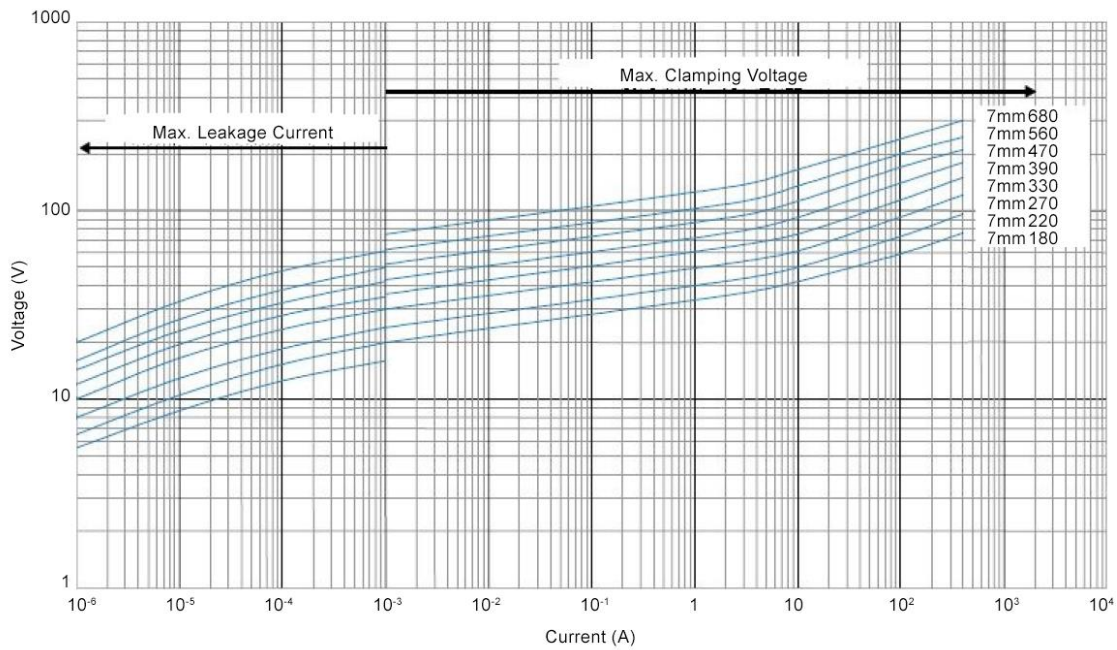

Voltage Curve – 7 mm 820K-471K

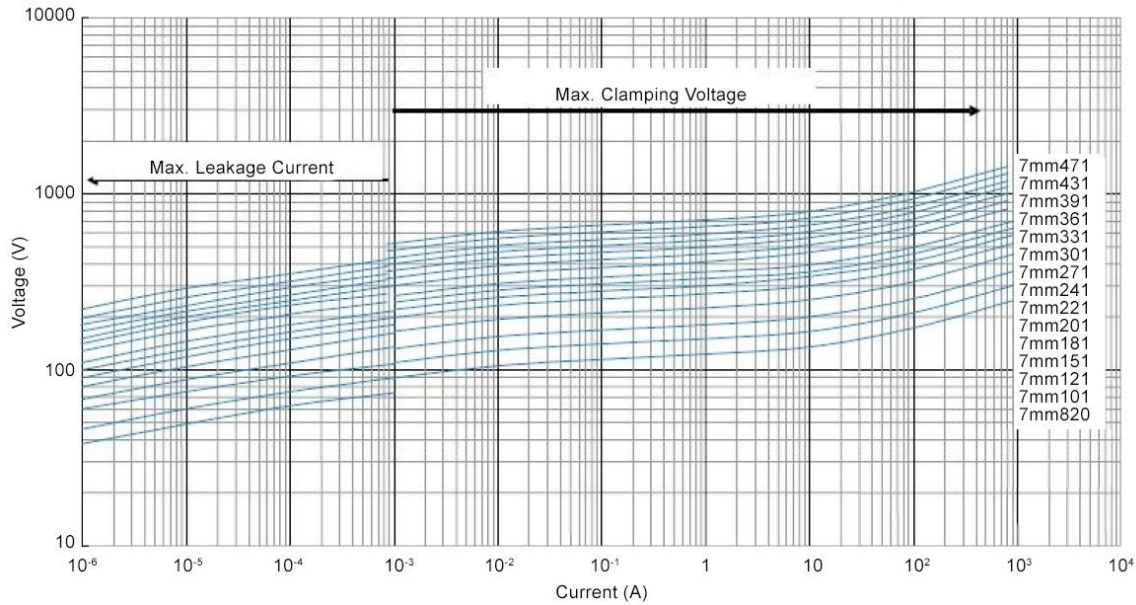

Voltage Curve – 7 mm 511K – 821K

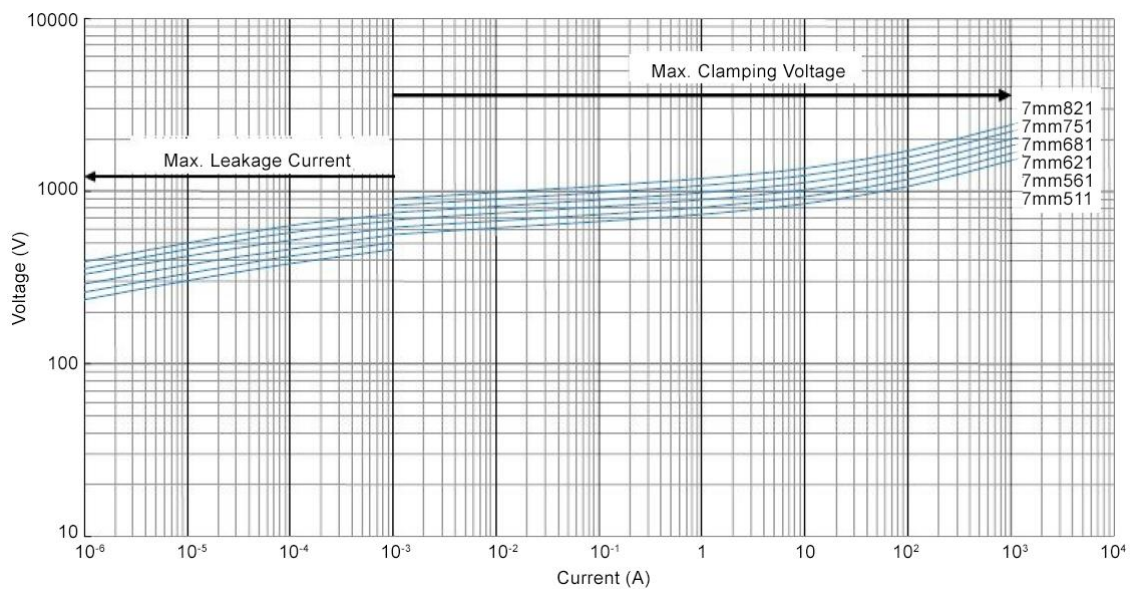

Voltage Curve – 10 mm 180L-680K

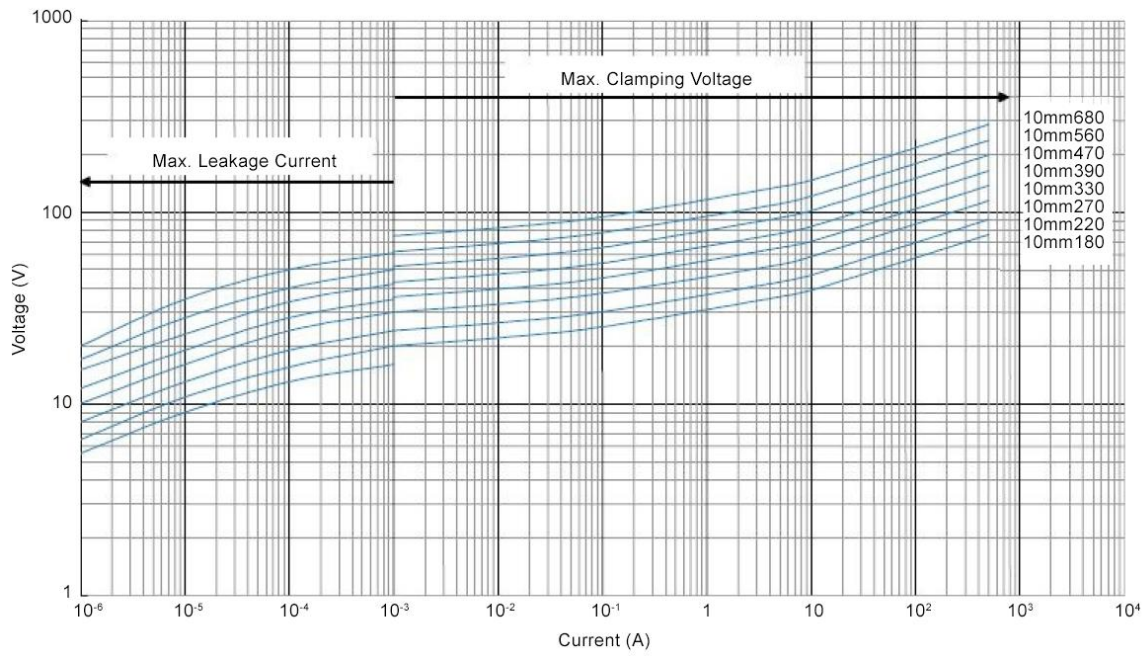

Voltage Curve – 10 mm 820K-751K

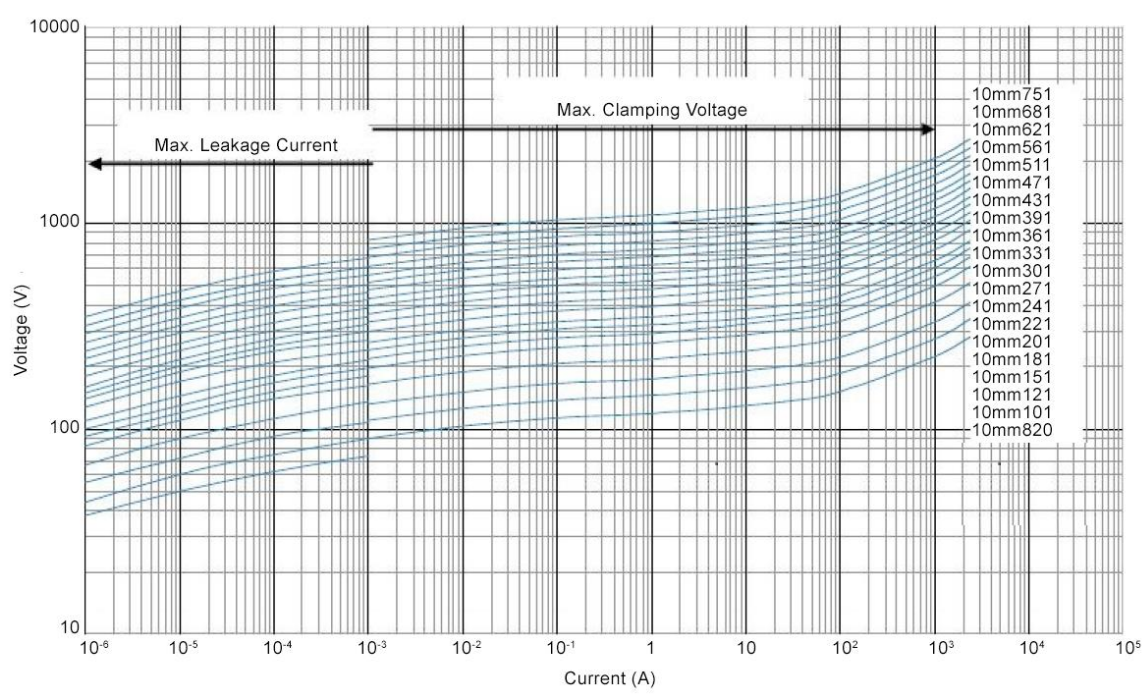

Voltage Curve – 10 mm 821K-182K

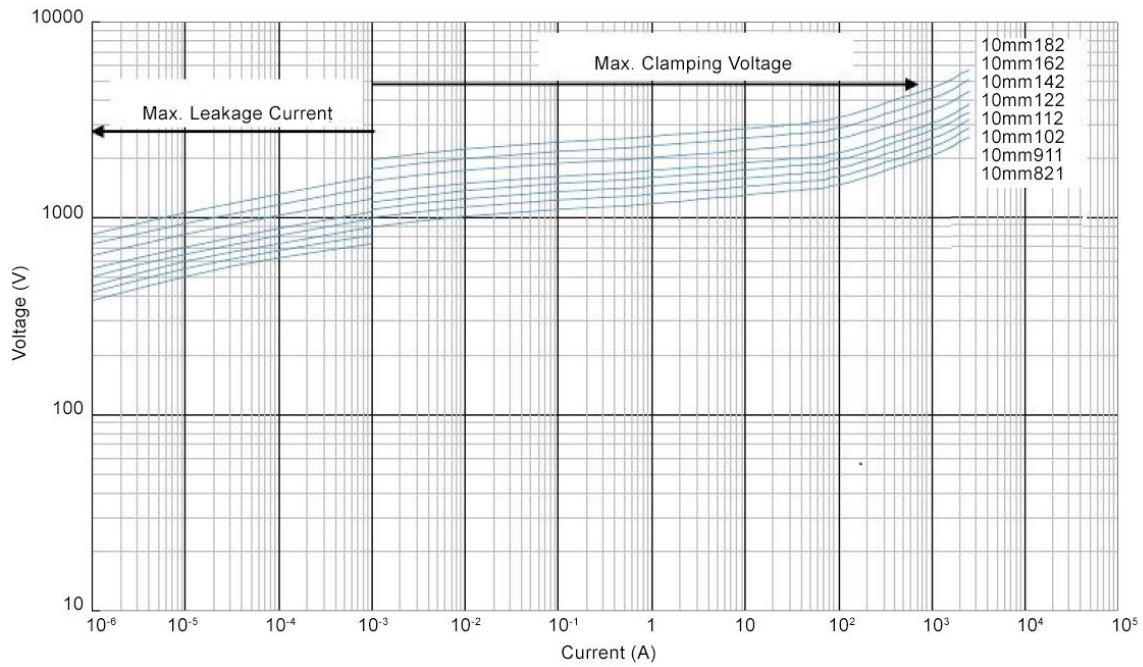

Voltage Curve – 14 mm 180L-680K

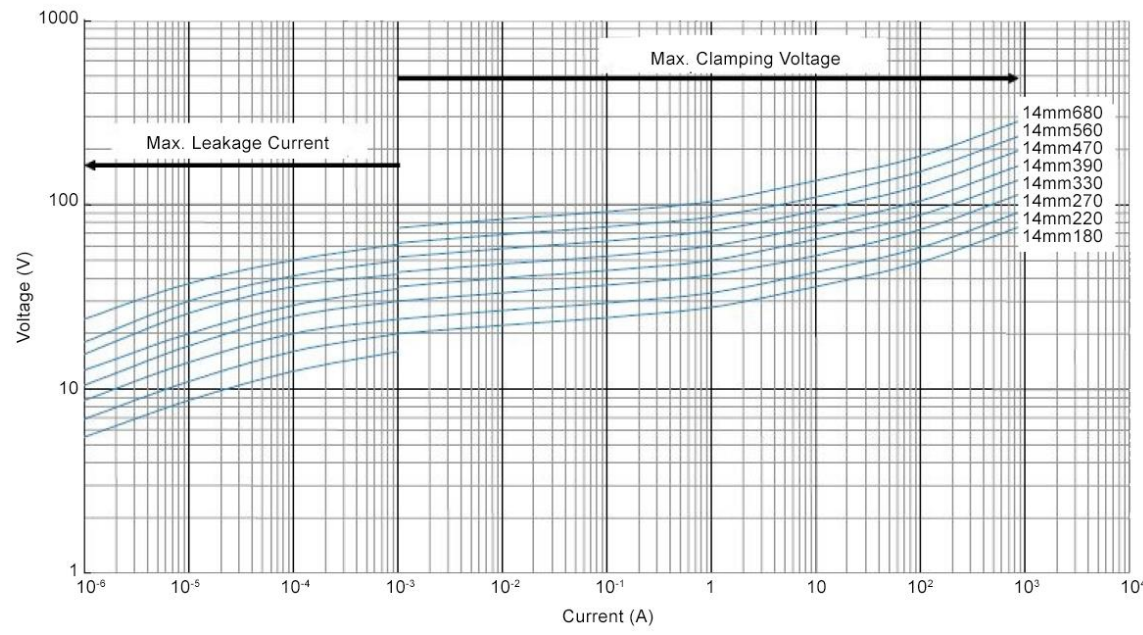

Voltage Curve – 14 mm 820K-751K

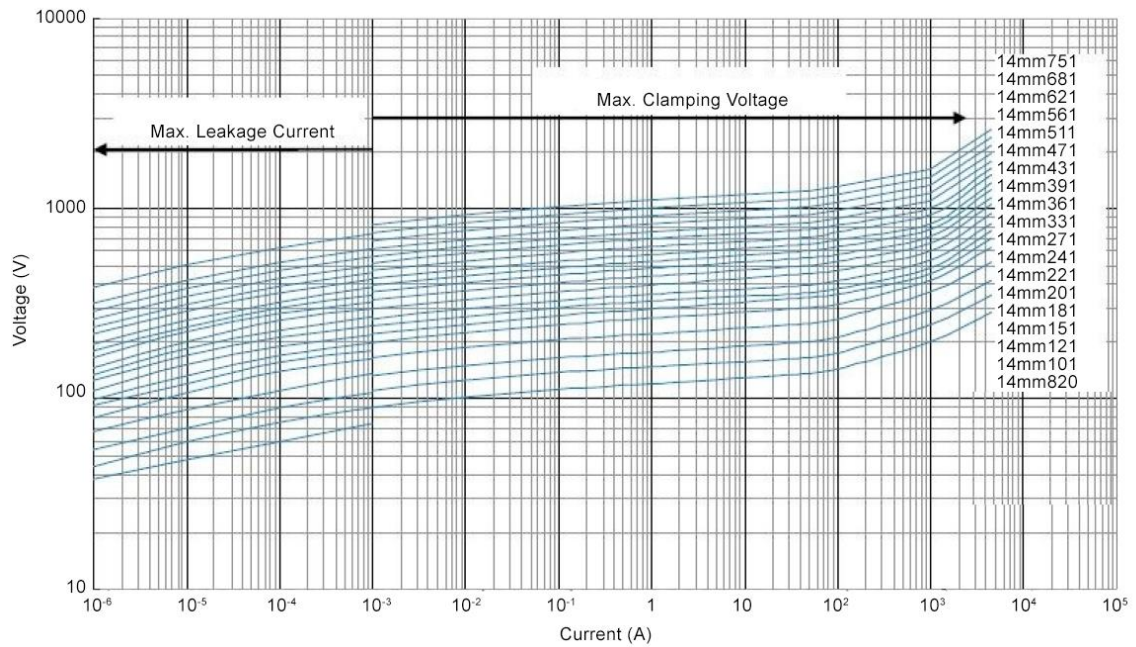

Voltage Curve – 14 mm 821K-182K

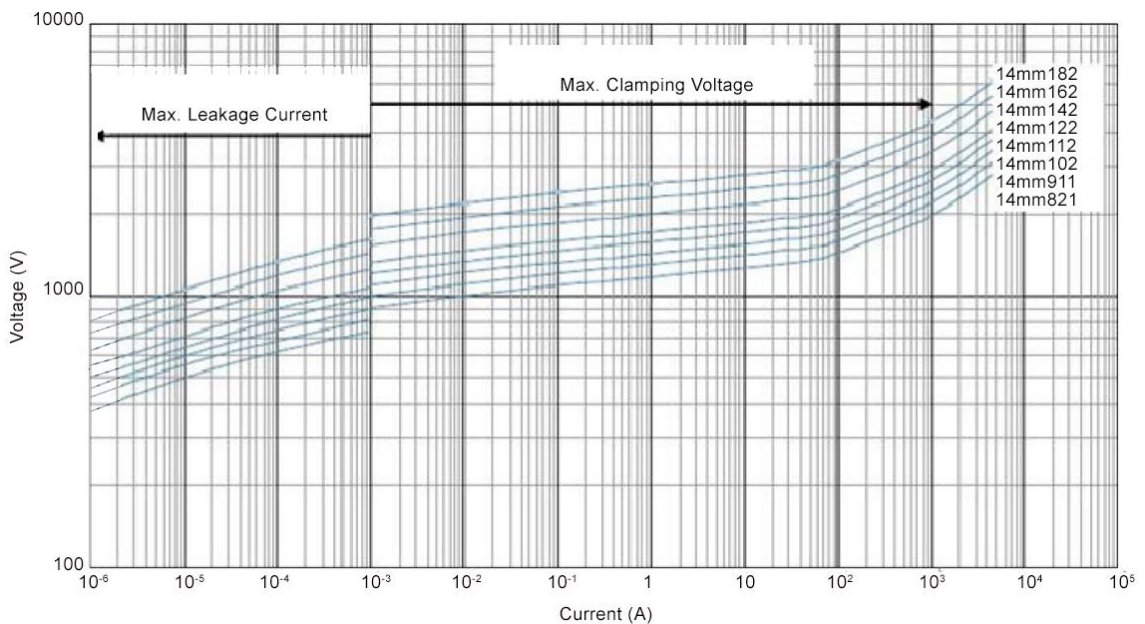

Voltage Curve – 20 mm 180K-680K

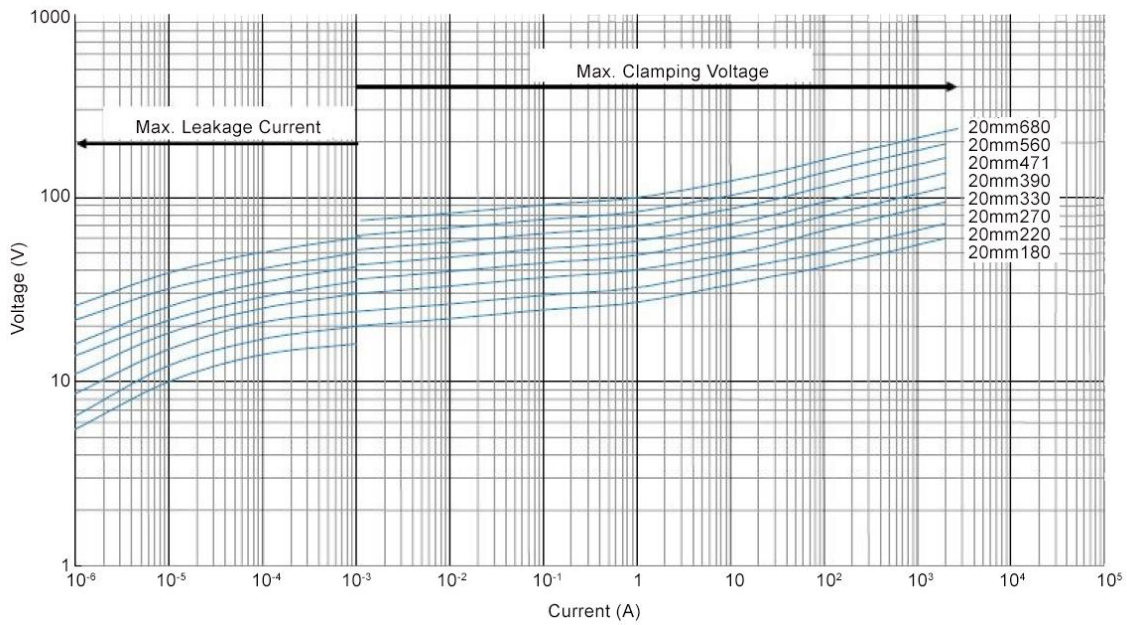

Voltage Curve – 20 mm 820K-751K

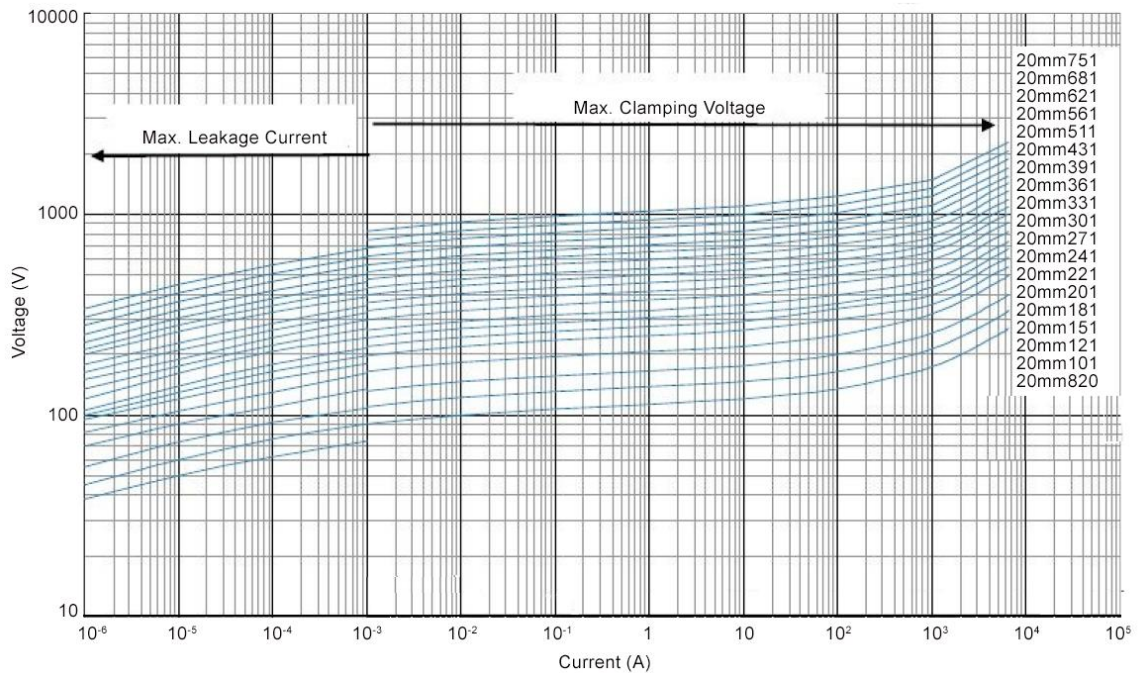

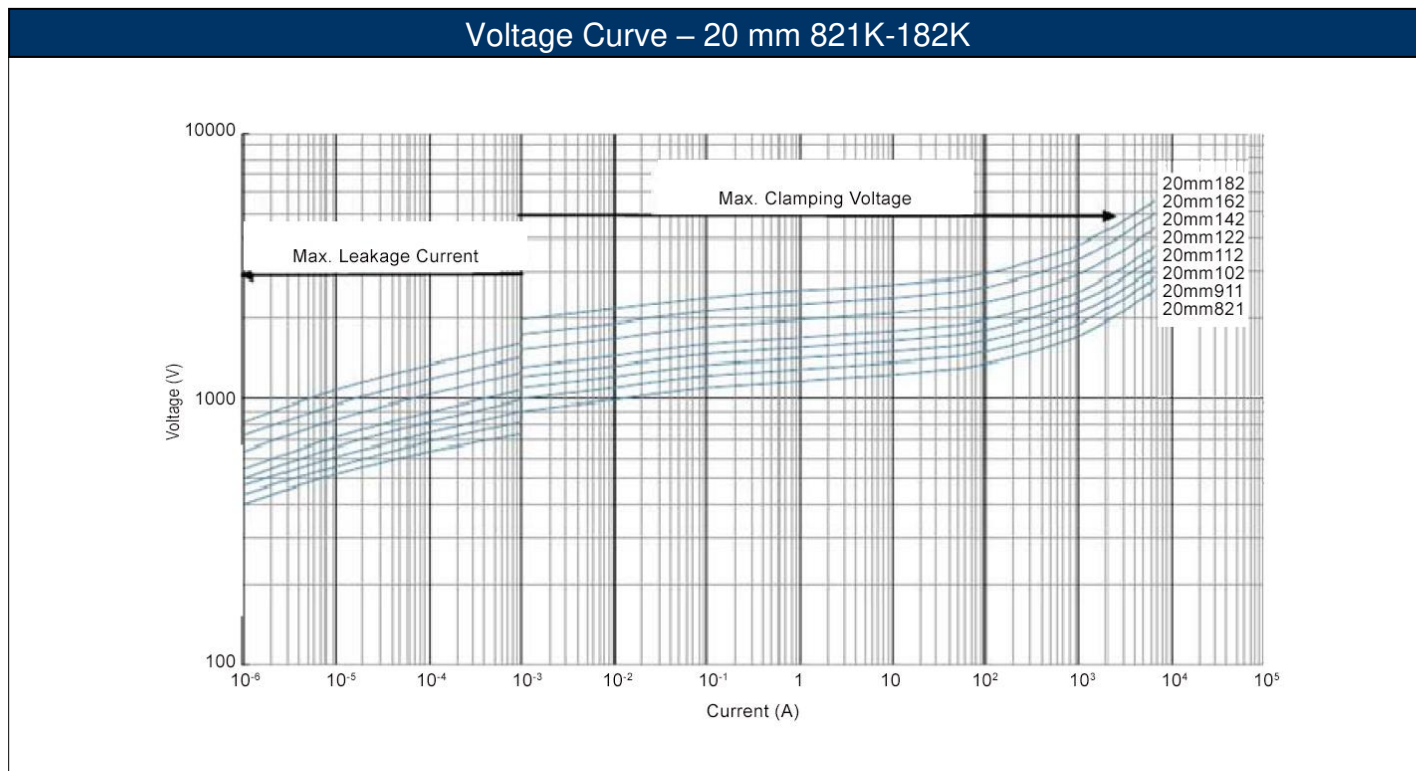

RoHS Compliance

Stackpole Electronics has joined the worldwide effort to reduce the amount of lead in electronic components and to meet the various regulatory requirements now prevalent, such as the European Union’s directive regarding “Restrictions on Hazardous Substances” (RoHS 3). As part of this ongoing program, we periodically update this document with the status regarding the availability of our compliant components. All our standard part numbers are compliant to EU Directive 2011/65/EU of the European Parliament as amended by Directive (EU) 2015/863/EU as regards the list of restricted substances.

RoHS Compliance Status						
Standard Product Series	Description	Package / Termination Type	Standard Series RoHS Compliant	Lead-Free Termination Composition	Lead-Free Mfg. Effective Date (Std Product Series)	Lead-Free Effective Date Code (YY/WW)
RV	Standard Metal Oxide Varistor	Leaded	YES	96.5/3/0.5 Sn/Ag/Cu	Always	Always

“Conflict Metals” Commitment

We at Stackpole Electronics, Inc. are joined with our industry in opposing the use of metals mined in the “conflict region” of the eastern Democratic Republic of the Congo (DRC) in our products. Recognizing that the supply chain for metals used in the electronics industry is very complex, we work closely with our own suppliers to verify to the extent possible that the materials and products we supply do not contain metals sourced from this conflict region. As such, we are in compliance with the requirements of Dodd-Frank Act regarding Conflict Minerals.

Compliance to “REACH”

We certify that all passive components supplied by Stackpole Electronics, Inc. are SVHC (Substances of Very High Concern) free and compliant with the requirements of EU Directive 1907/2006/EC, “The Registration, Evaluation, Authorization and Restriction of Chemicals”, otherwise referred to as REACH. Contact us for complete list of REACH Substance Candidate List.

Environmental Policy

It is the policy of Stackpole Electronics, Inc. (SEI) to protect the environment in all localities in which we operate. We continually strive to improve our effect on the environment. We observe all applicable laws and regulations regarding the protection of our environment and all requests related to the environment to which we have agreed. We are committed to the prevention of all forms of pollution.

How to Order

