

8A, 18V, Synchronous Step-Down Converter

Purpose

The RT7299BHGQW is a current mode step-down converter with the input voltage range from 4.5V to 18V and provides 8A output current. This document explains the function and use of the RT7299BHGQW evaluation board (EVB), and provides information to enable operation, modification of the evaluation board and circuit to suit individual requirements.

Table of Contents

Purpose.....	1
Introduction.....	2
Key Performance Summary Table.....	2
Bench Test Setup Conditions.....	3
Schematic, Bill of Materials & Board Layout.....	5
More Information.....	8
Important Notice for Richtek Evaluation Board.....	8

Introduction

General Product Information

The RT7299BHGQW is a high efficiency, monolithic synchronous step-down DC/DC converter that can deliver up to 8A output current from a 4.5V to 18V input supply. The RT7299BHGQW current-mode architecture with external compensation allows the transient response to be optimized over a wide range of loads and output capacitors. Cycle-by-cycle current limit provides protection against shorted outputs and soft-start eliminates input current surge during startup. Fault condition protections include output under-voltage protection, output over-voltage protection, and over-temperature protection. The low current shutdown mode provides output disconnection, enabling easy power management in battery-powered systems.

Product Feature

- Low $R_{DS(ON)}$ Power MOSFET Switches 26m Ω /19m Ω
- Input Voltage Range : 4.5V to 18V
- Adjustable Switching Frequency : 200kHz to 1.6MHz
- Current-Mode Control
- Synchronous to External Clock : 200kHz to 1.6MHz
- Accurate Voltage Reference 0.6V \pm 1%
- Monotonic Start-Up into Pre-biased Outputs
- Adjustable Soft-Start
- Power Good Indicator
- Input Under-Voltage Lockout
- Selectable Hiccup Mode and Latch-Off Mode Under-Voltage Protection
- Over-Temperature and Over-Voltage Protection

Key Performance Summary Table

Key Features	Evaluation Board Number : PCB069_V1
Default Input Voltage	12V
Max Output Current	8A
Default Output Voltage	3.3V
Default Marking & Package Type	RT7299BHGQW, WQFN-14AL 3.5x3.5
Operation Frequency	Steady 200kHz to 1.6MHz

Bench Test Setup Conditions

Headers Description and Placement

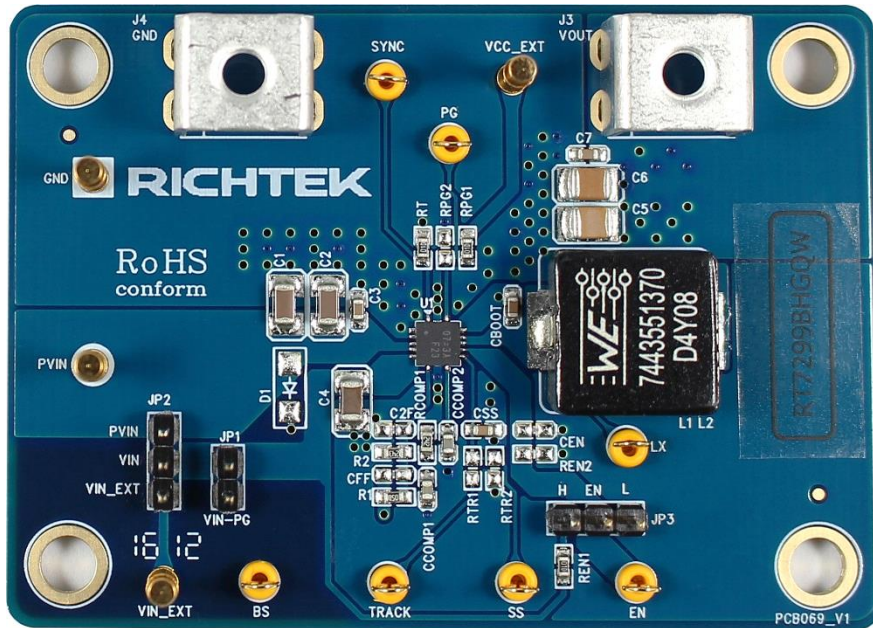

Please carefully inspect the EVB IC and external components, comparing them to the following Bill of Materials, to ensure that all components are installed and undamaged. If any components are missing or damaged during transportation, please contact the distributor or send e-mail to evb_service@richtek.com.

Test Points

The EVB is provided with the test points and pin names listed in the table below.

Test point/ Pin name	Signal	Comment (expected waveforms or voltage levels on test points)
RT/SYNC	Oscillator Resistor and External Frequency Synchronization Input	Oscillator Resistor and External Frequency Synchronization Input. Connecting a resistor from this pin to GND sets the switching frequency or connecting an external clock to this pin changes the switching frequency.
GND	System Ground	System Ground. Provide the ground return path for the control circuitry and low-side power MOSFET. The exposed pad must be soldered to a large PCB and connected to GND for minimum power dissipation.
PVIN	Power Input	Power Input. Supplies the power switches of the device.
VIN	Supply Voltage Input	Supply Voltage Input. Supplies the control circuitry and internal reference of the device.
FB	Feedback Voltage Input	Feedback Voltage Input. This pin is used to set the desired output voltage via an external resistive divider. The feedback reference voltage is 0.6V typically.
COMP	Compensation Node	Compensation Node. The current comparator threshold increases with this control voltage. Connect external compensation elements to this pin to stabilize the control loop.
SS/TR	Soft-Start and Tracking Control Input	Soft-Start and Tracking Control Input. Connect a capacitor from SS to GND to set the soft-start period. The soft-start period can be used to track and sequence when the external voltage on this pin overrides the internal reference.

Test point/ Pin name	Signal	Comment (expected waveforms or voltage levels on test points)
EN	Enable Control Input	Enable Control Input. Floating this pin or connecting this pin to logic high can enable the device and connecting this pin to GND can disable the device.
LX	Switch node test point	Switch Node. LX is the switching node that supplies power to the output and connect the output LC filter from LX to the output load.
BOOT	Bootstrap Supply for High-Side Gate Driver	Bootstrap Supply for High-Side Gate Driver. Connect a 100nF or greater capacitor from LX to BOOT to power the high-side switch.
PGOOD	Power Good Indicator Output	Power Good Indicator Output. This pin is an open-drain logic output that is pulled to ground when the output voltage is lower or higher than its specified threshold under the conditions of OVP, OTP, dropout, EN shutdown, or during slow start.

Power-up & Measurement Procedure

1. Apply a 12V nominal input power supply ($4.5V < V_{IN} < 18V$) to the VIN and GND terminals.
2. Set the jumper at J9 to connect terminals 1 and 2, connecting EN to VIN through resistor REN1, to enable operation.
3. Verify the output voltage (approximately 3.3V) between VOUT and GND.
4. Connect an external load up to 8A to the VOUT and GND terminals and verify the output voltage and current.

Output Voltage Setting

Set the output voltage with the resistive divider (R1, R2) between VOUT and GND with the midpoint connected to FB. The output is set by the following formula :

$$V_{OUT} = V_{FB} \times \left(1 + \frac{R1}{R2}\right)$$

Schematic, Bill of Materials & Board Layout

EVB Schematic Diagram

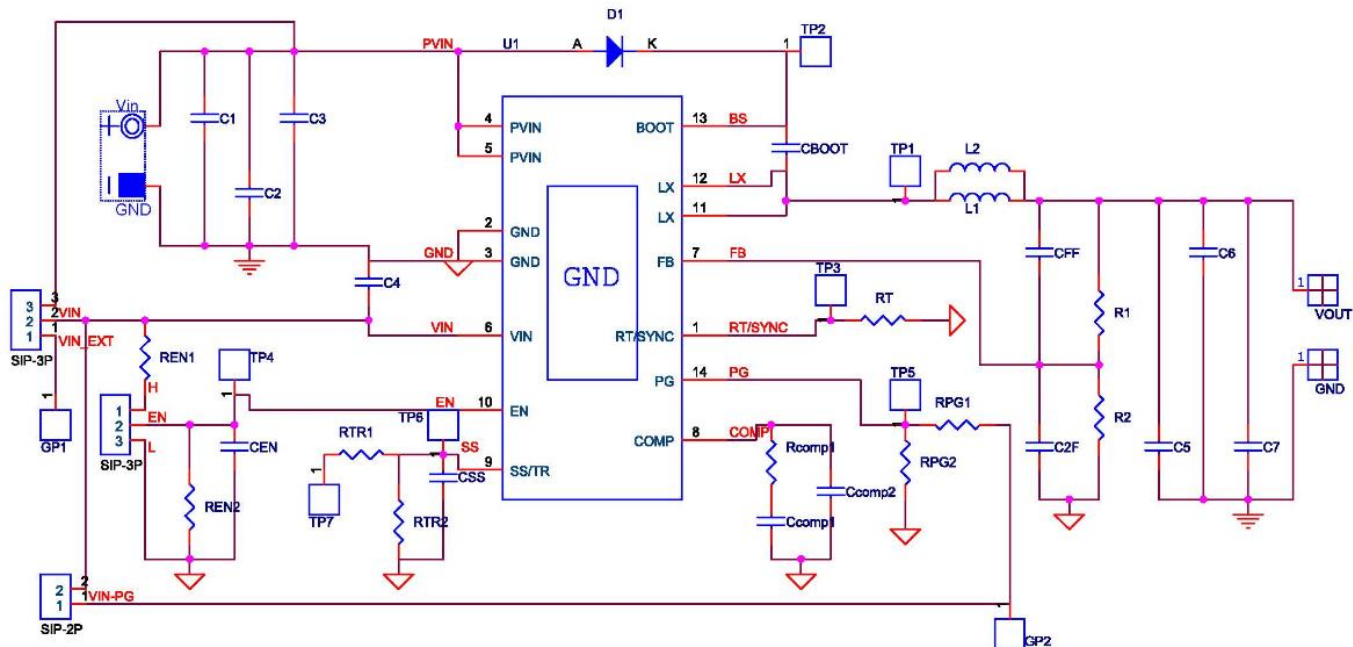

Bill of Materials

Reference	Qty	Part Number	Description	Package	Manufacture
U1	1	RT7299BHGQW	DC/DC Converter	WQFN-14AL 3.5x3.5	RICHTEK
R1	1	0603 110K 1%	110kΩ	0603	WALSIN
R2	1	0603 24K0 1%	24kΩ	0603	WALSIN
RCOMP1	1	0603 2K40 1%	2.4kΩ	0603	WALSIN
RT, RPG1, REN1	3	0603 100K 1%	100kΩ	0603	WALSIN
C1, C2	2	UMK325BJ106MM-T	10μF/50V/X7R	1206	TAIYO YUDEN
C5, C6	2	C3225X5R1E226MT	22μF/25V/X7R	1210	TDK
CCOMP1	1	0603B822K500CT	8.2nF/50V/X7R	0603	WALSIN
CCOMP2	1	0603B181K500	180pF/50V/X7R	0603	WALSIN
C4	1	GRM31CR71H475KA12L	4.7μF/50V/X7R	1206	muRata
CSS	1	0603B103K500	10nF/50V/X7R	0603	WALSIN
C3, C7, CBOOT	3	C1608X7R1H104KT000N	0.1μF/50V/X7R	0603	TDK
L1	1		3.7μH		
CFF, C2F, CEN, REN2, RTR1, RTR2, RPG2	7		N/A		

PCB Layout

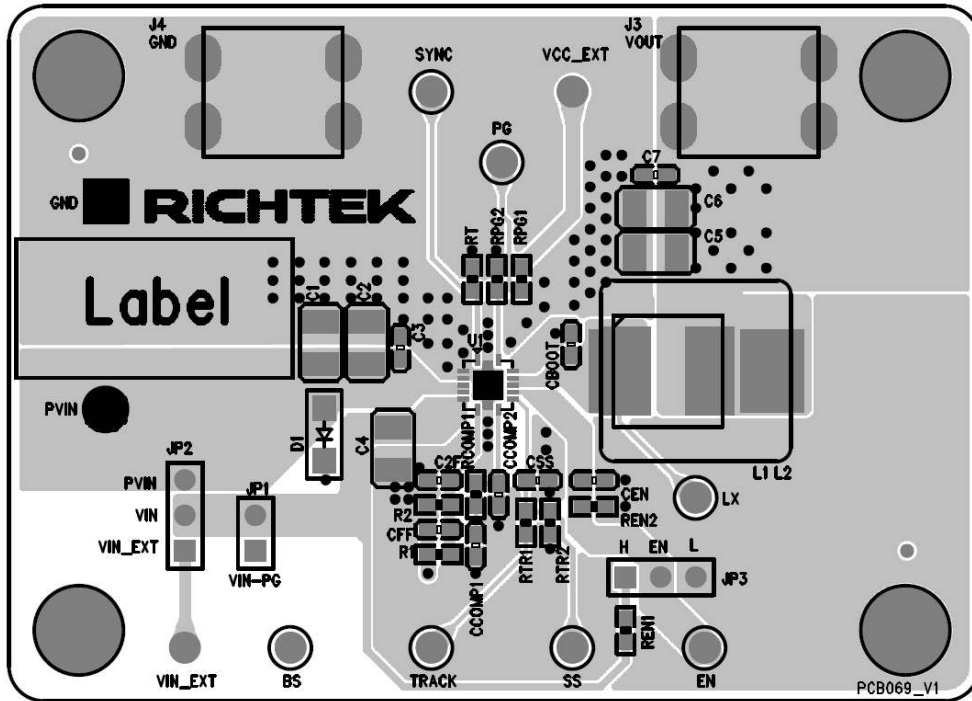

Top View (1st layer)

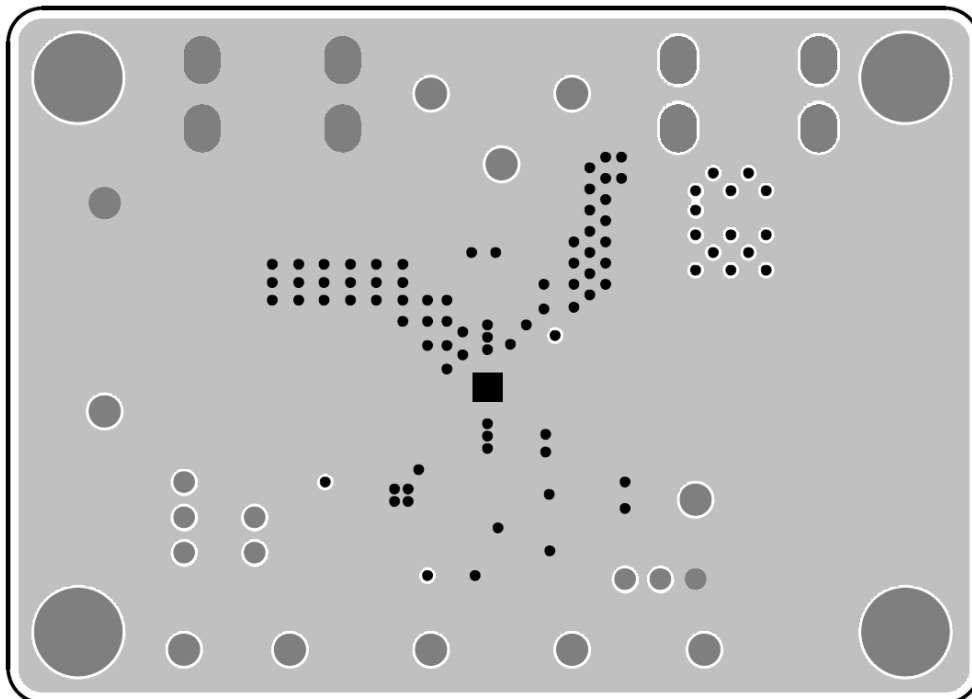

PCB Layout—Inner Side (2nd Layer)

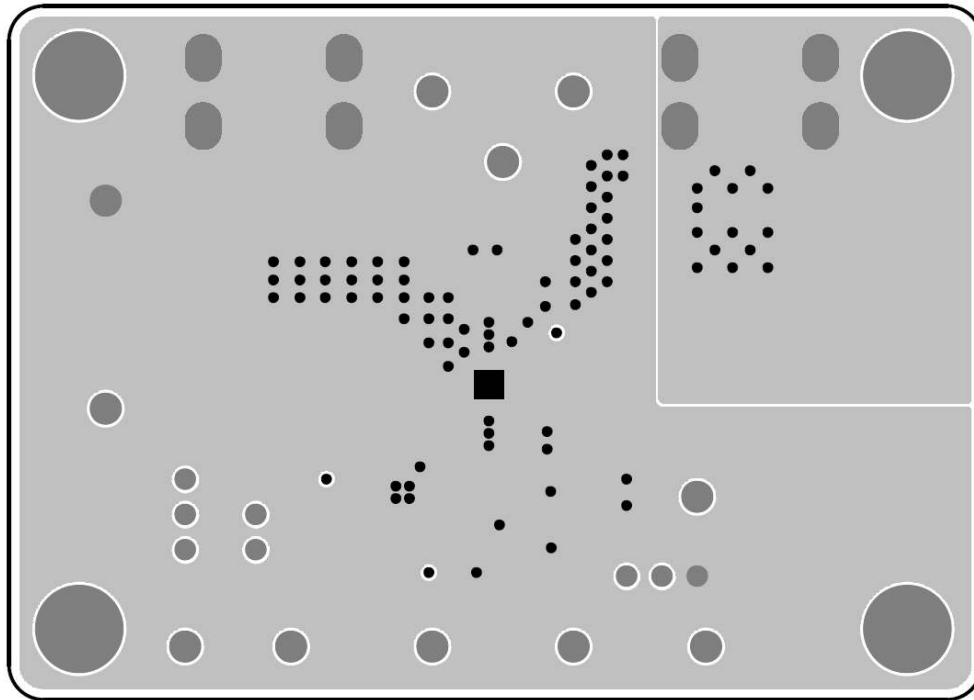

PCB Layout—Inner Side (3rd Layer)

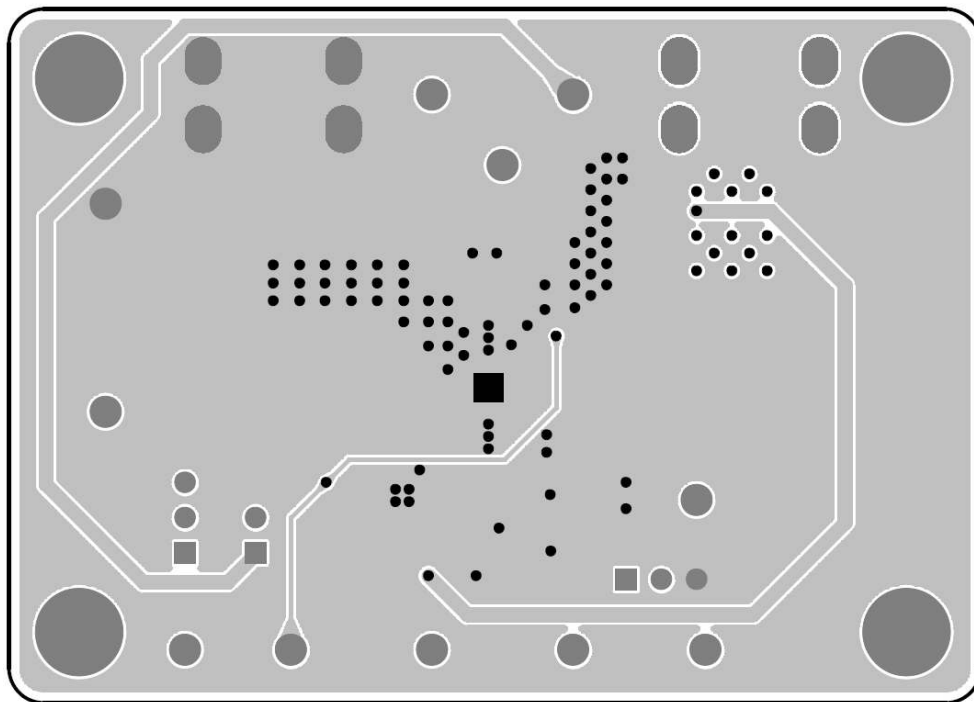

Bottom View (4th Layer)

More Information

For more information, please find the related datasheet or application notes from Richtek website <http://www.richtek.com>.

Important Notice for Richtek Evaluation Board

THIS DOCUMENT IS FOR REFERENCE ONLY, NOTHING CONTAINED IN THIS DOCUMENT SHALL BE CONSTRUED AS RICHTEK'S WARRANTY, EXPRESS OR IMPLIED, UNDER CONTRACT, TORT OR STATUTORY, WITH RESPECT TO THE PRESENTATION HEREIN. IN NO EVENT SHALL RICHTEK BE LIABLE TO BUYER OR USER FOR ANY AND ALL DAMAGES INCLUDING WITHOUT LIMITATION TO DIRECT, INDIRECT, SPECIAL, PUNITIVE OR CONSEQUENTIAL DAMAGES.