

THIS DRAWING IS UNPUBLISHED. RELEASED FOR PUBLICATION
 © COPYRIGHT - By - ALL RIGHTS RESERVED.

LOC		DIST		REVISIONS			
P	LR	DESCRIPTION	DATE	OWN	APPD		
AJ	16	A2	REVISED PER ECO-11-005030	11MAR11	RK	HMR	

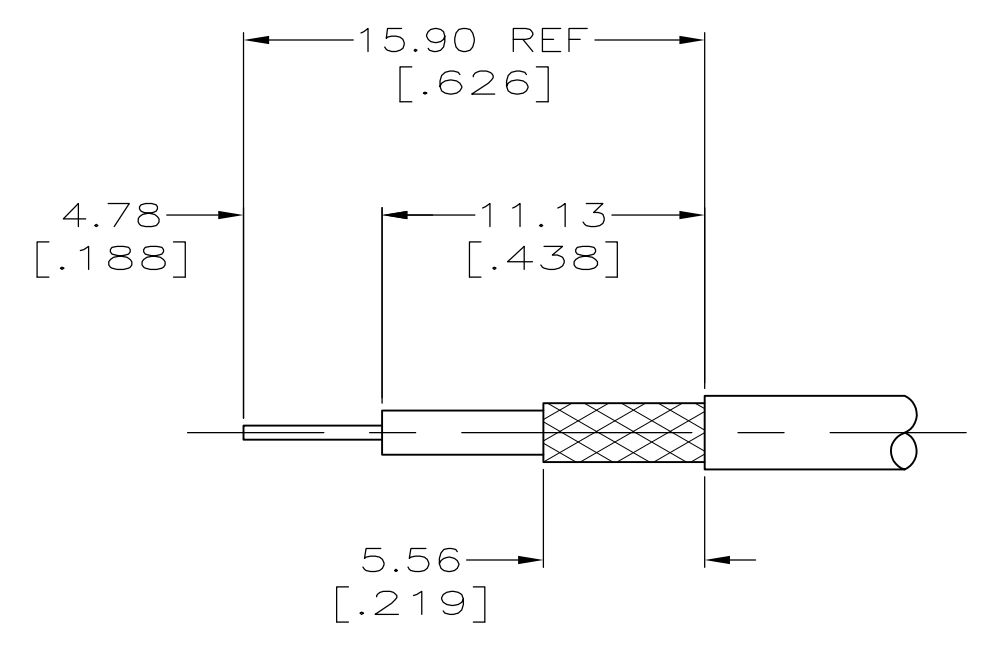
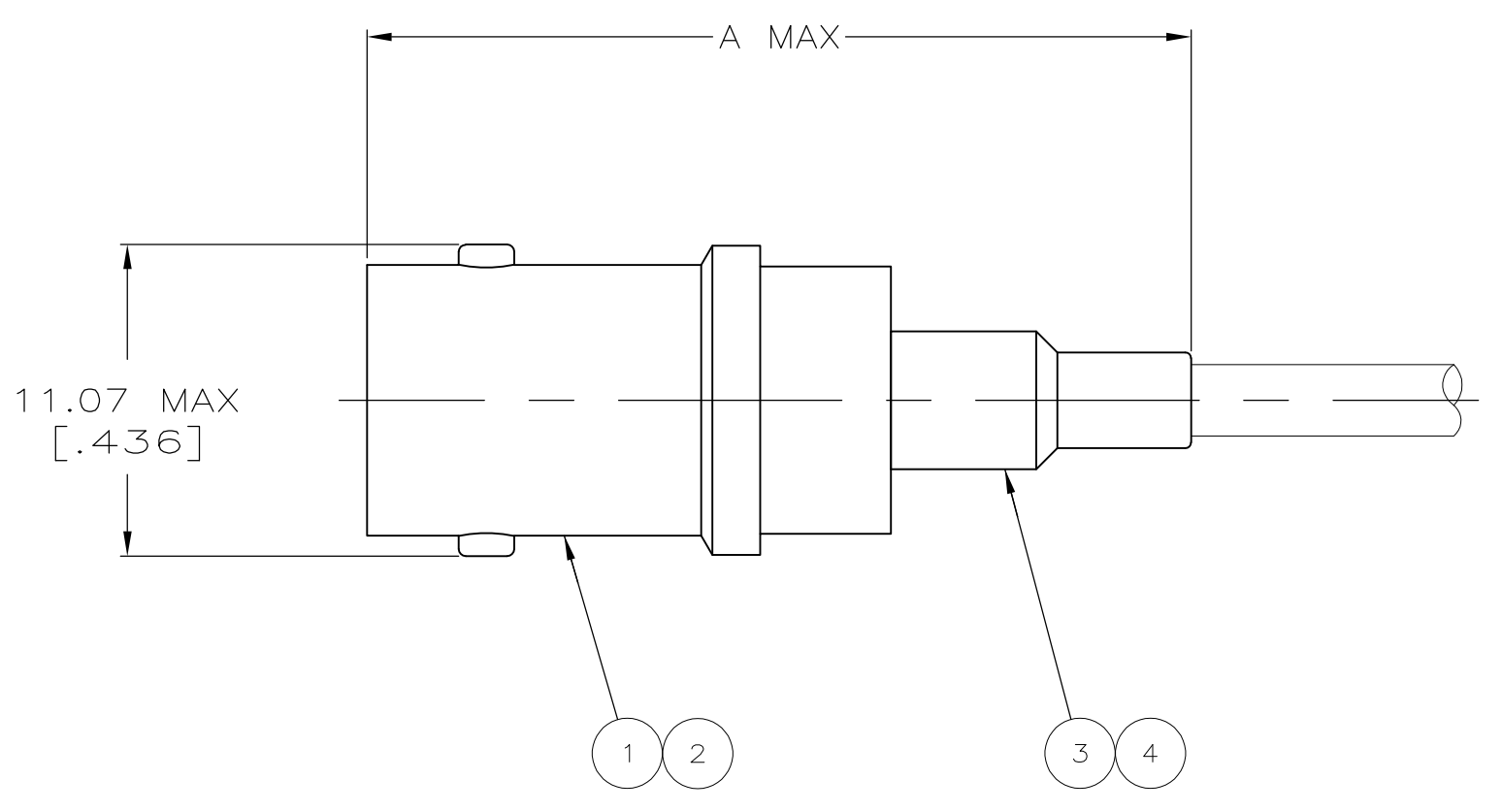

- 1. USE INSTRUCTION SHEET 408-9050
- △ USE WITH PRO-CRIMPER 354940-1.
- △ OBSOLETE PARTS: OBSOLETE CIS STREAMLINING PER D.RENAUD/D.SINISI

RECOMMENDED STRIP LENGTH

△ OBSOLETE	BELDEN YR40862	220189-1	220187-1	30.48 [1.200]	-	9-50427-1	3-221149-6	221455-1	4-5228979-7
	RG-174/U,188/U & 316/U	220210-1	220009-5	30.48 [1.200]	21427-2	9-328666-0	2-221149-0	221455-3	5228979-7
	RG-59/U,59A/U,59B/U,62/U,62A/U & 62B/U	220189-2	220187-2	30.48 [1.200]	-	9-50428-0	1-221149-3	221455-2	5228979-6
	RG-58/U,58A/U,58B/U,58C/U,141/U & 141A/U	220189-1	220187-1	30.48 [1.200]	-	9-50427-1	221149-6	221455-1	5228979-5
	FOR USE WITH CABLE	DIE SET △2	CRIMP TOOL	A	④ BUSHING QTY = 1	③ FERRULE QTY = 1	② CONTACT QTY = 1	① JACK ASSY QTY = 1	PART NO

THIS DRAWING IS A CONTROLLED DOCUMENT.

DIMENSIONS: MM (INCHES)	TOLERANCES UNLESS OTHERWISE SPECIFIED:	0 PLC ± -	1 PLC ± -	2 PLC ± -	3 PLC ± .016	4 PLC ± -	ANGLES ± -	FINISH -
-------------------------	--	-----------	-----------	-----------	--------------	-----------	------------	----------

DWN: L. VARELA - DOCK5
 CHK: J. HAVENER
 APVD: J. LIPPFERT
 PRODUCT SPEC: 108-12047
 APPLICATION SPEC: -
 WEIGHT: -
 MATERIAL: -
 FINISH: -

NAME: JACK, COMMERCIAL, BNC
 SIZE: A1
 CAGE CODE: 100779
 DRAWING NO: C=5228979
 SCALE: 4:1
 SHEET: 1 OF 1
 REV: A2

CUSTOMER DRAWING
 SCALE: 4:1
 SHEET: 1 OF 1
 REV: A2