

M3C102D
MINI M3.0x0.5mm
1,000pF Cap. Feed-Thru

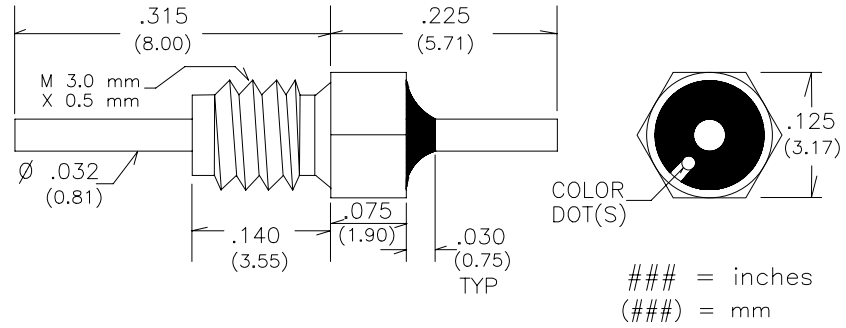
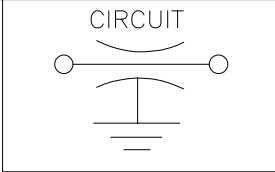

- * RoHS Compliant
- * Discoidal Capacitor Construction

PART NUMBER	EMI P/N	CAP. (pF)	COLOR DOT(S)	MAX. WVDC	DC AMPS	MINIMUM NO LOAD INSERTION LOSS				
						1 MHz	10 MHz	100 MHz	1 GHz	10 GHz
M3C102D		1,000	WHITE	200	10	---	5	20	35	45

ELECTRICAL

CAPACITANCE TOLERANCE: +100/-0%
 DISSIPATION FACTOR: 3.5% MAX.
 INSULATION RESISTANCE:
 25° C=10,000Mohm Min.
 125° C= 1,000Mohm Min.
 DIELECTRIC STRENGTH (DWV):
 250% of WVDC (5 seconds)
 TEMPERATURE CHARACTERISTIC:
 X7R or better

PHYSICAL

DIMENSION TOLERANCE:
 CASE LENGTH: +/- .010" (.250mm)
 LEAD LENGTH: +/- .030" (.762mm)
 LEAD DIAMETER: +/- .002" (.051mm)
 MATERIAL AND FINISH:
 CASE: C12L14 CRS
 LEAD: Copper (1/2 Hard)
 FINISH: Silver per QQ-S-365

IDENTIFICATION & LIMITS

MARKING: Color Dot standard per chart
 OPERATING TEMP: -55° C to +125° C
 INSTALLATION TEMP: N/A
 MAXIMUM MOUNTING TORQUE: 2.0 in*lbs

VENDOR:
 EMI Filter Company
 12750 59th Way N.
 Clearwater, FL 33760
 (727) 585-7990
 (727) 586-5138 Fax
 www.emifiltercompany.com

FILTERS, EMI, MINIATURE M 3.0 mm X 0.5 mm THREADED BODY		
FSCM NO.	DWG NO.	REV
	M3C102D REVD	D