

NOTES:

1. MATERIALS AND FINISHES:
 BODIES, HEX NUT & RETAINING RING - BRASS, NICKEL PLATED
 LOCK WASHER - STAINLESS STEEL, PASSIVATED
 CONTACT - BeCu, GOLD PLATED
 INSULATOR - PTFE, NATURAL
 GASKET - SILICONE RUBBER, RED
2. ELECTRICAL:
 A. IMPEDANCE: 50 OHM
 B. FREQUENCY RANGE: DC - 6 GHz
 C. VSWR: 1.20 MAX @ DC - 3 GHz
 1.40 MAX @ 3 - 6 GHz
 D. DIELECTRIC WITHSTANDING VOLTAGE: 500 VRMS MIN.
3. MECHANICAL:
 A. DURABILITY: 500 CYCLES MIN FOR BNC SIDE
 100 CYCLES MIN FOR AMC SIDE
 B. TEMPERATURE RANGE: -65 C TO +165 C
4. PACKAGING:
 A. QUANTITY: SINGLE PACK
 B. MARKING: BAG TO BE MARKED
 "AMPHENOL, AD-BNCJAMCJ-1 & DATE CODE"

REVISIONS				
REV	DESCRIPTION	DATE	ECN	APPR
A	RELEASE TO MFG.	10-Feb-21	15545	S.HSIEH

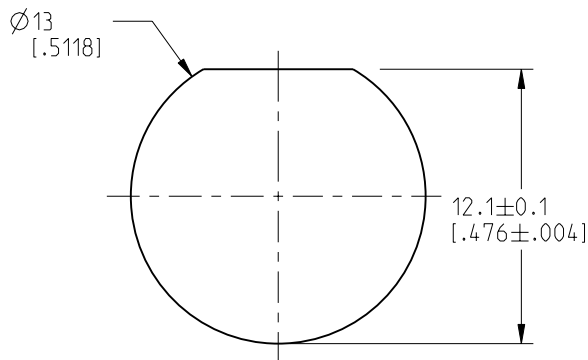

RECOMMENDED PCB PANEL CUTOUT

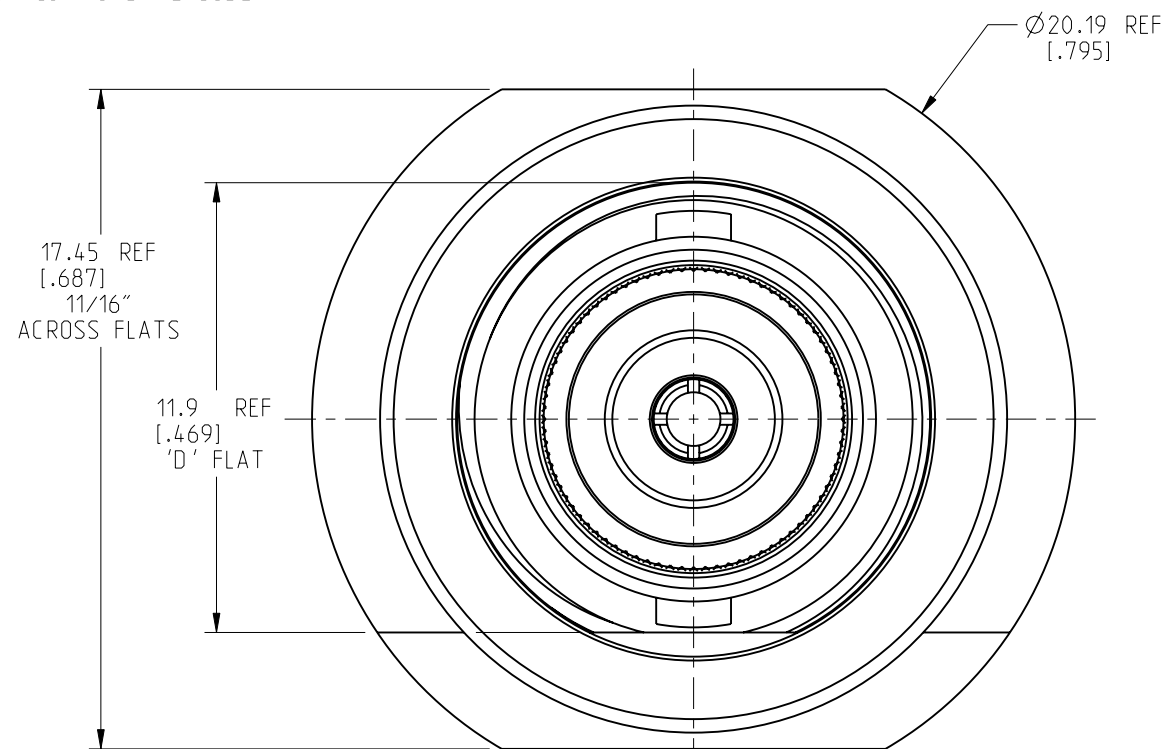
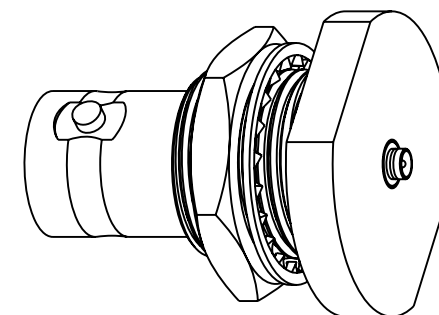

**LOCK WASHER AND HEX NUT
ARE NOT SHOWN IN THE VIEW**

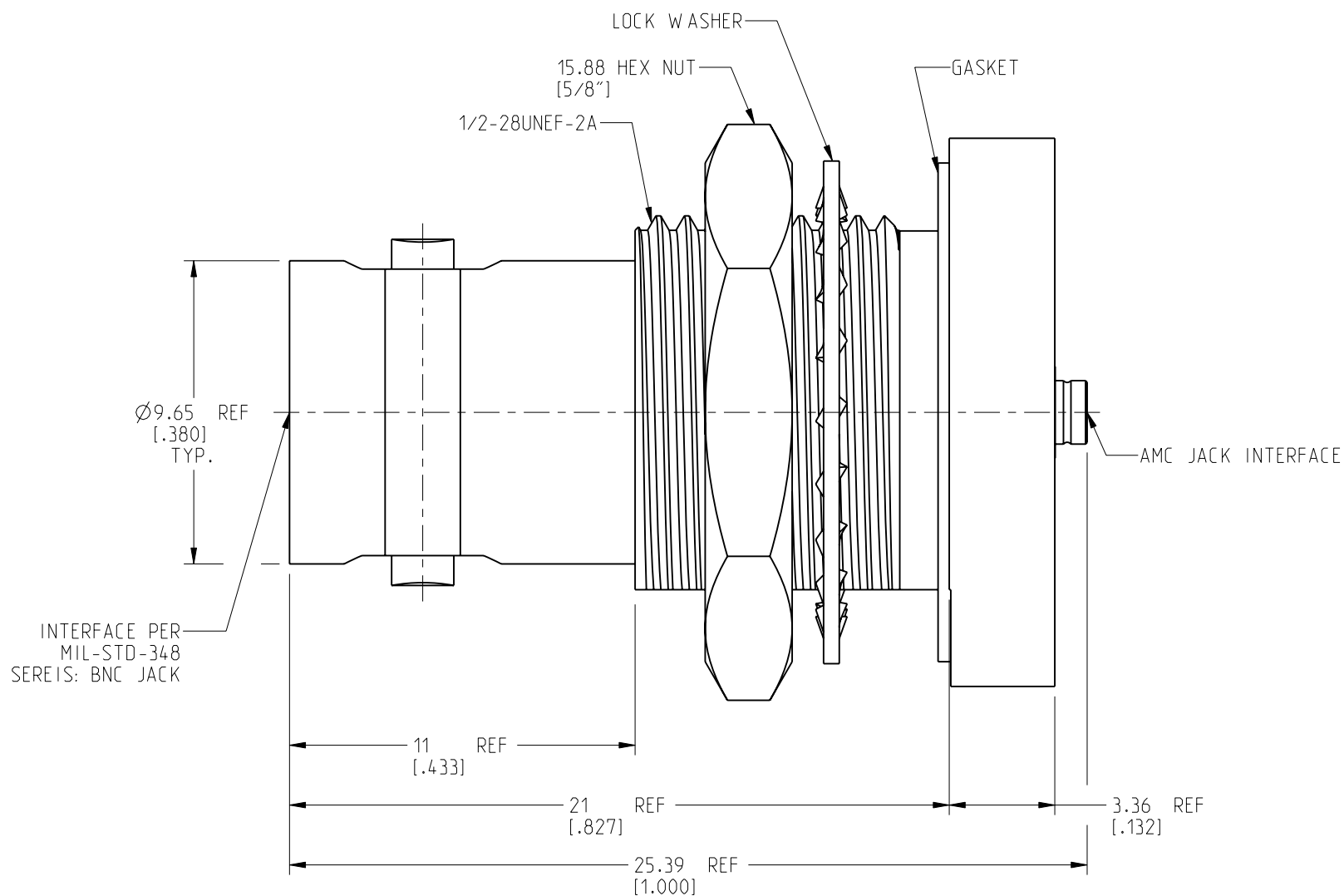

CUSTOMER OUTLINE DRAWING

ALL OTHER SHEETS ARE FOR INTERNAL USE ONLY

NOTICE: These drawings, specifications, or other data (1) are, and remain the property of Amphenol corp. (2) must be returned upon request; and (3) are confidential and not to be disclosed to any person other than those to whom they are given by Amphenol Corp. The furnishing of these drawings, specifications, or other data by Amphenol Corp., or to any other person to anyone for any purpose is not to be regarded by implication or otherwise in any manner licensing, granting rights to permitting such holder or any other person to manufacture, use or sell any product, process or design, patented or otherwise, that may in any way be related to or disclosed by said drawings, specifications, or other data.

UNLESS OTHERWISE SPECIFIED
 DIMENSIONS ARE METRIC (INCHES) AND TOLERANCES ARE:
 <0.5mm = ±0.05mm [$<0.020 = \pm 0.002$]
 >0.5 - 6mm = ±0.1mm [$>0.020 - 0.236 = \pm 0.004$]
 >6.00 - 30mm = ±0.2mm [$>0.236 - 1.181 = \pm 0.008$]
 >30.00 - 120mm = ±0.3mm [$>1.181 - 4.725 = \pm 0.012$]

MATERIAL
SEE NOTES

TITLE
BNC BULKHEAD JACK
TO AMC JACK
ADAPTER

Amphenol RF

SIZE B	DRAWING NO.	AD-BNCJAMCJ-1	REV A
	ITEM NO.	AD-BNCJAMCJ-1	
	PART NO.	AD-BNCJAMCJ-1	

THIRD ANGLE PROJ.	REFERENCE AD-BNCJMCXJ-1	EAR# 10089
-------------------	----------------------------	---------------

ENGINEER E.WU	DATE 4-FEB-21
------------------	------------------

SHEET NO. 2 OF 2	SCALE: 5.0:1.0
------------------	----------------