

# SN54ALS299, SN74ALS299 8-BIT UNIVERSAL SHIFT/STORAGE REGISTERS WITH 3-STATE OUTPUTS

SDAS220B – DECEMBER 1982 – REVISED DECEMBER 1994

- **Multiplexed I/O Ports Provide Improved Bit Density**
- **Four Modes of Operation:**
  - Hold (Store)
  - Shift Right
  - Shift Left
  - Load Data
- **Operate With Outputs Enabled or at High Impedance**
- **3-State Outputs Drive Bus Lines Directly**
- **Can Be Cascaded for n-Bit Word Lengths**
- **Direct Overriding Clear**
- **Applications:**
  - Stacked or Push-Down Registers
  - Buffer Storage
  - Accumulator Registers
- **Package Options Include Plastic Small-Outline (DW) Packages, Ceramic Chip Carriers (FK), and Standard Plastic (N) and Ceramic (J) 300-mil DIPs**

## description

These 8-bit universal shift/storage registers feature multiplexed I/O ports to achieve full 8-bit data handling in a single 20-pin package. Two function-select ( $S_0$ ,  $S_1$ ) inputs and two output-enable ( $\overline{OE1}$ ,  $\overline{OE2}$ ) inputs can be used to choose the modes of operation listed in the function table.

Synchronous parallel loading is accomplished by taking both  $S_0$  and  $S_1$  high. This places the 3-state outputs in the high-impedance state and permits data applied on the I/O ports to be clocked into the register. Reading out of the register can be accomplished while the outputs are enabled in any mode. Clearing occurs asynchronously when the clear ( $\overline{CLR}$ ) input is low. Taking either  $\overline{OE1}$  or  $\overline{OE2}$  high disables the outputs, but has no effect on clearing, shifting, or storing data.

The SN54ALS299 is characterized for operation over the full military temperature range of  $-55^\circ\text{C}$  to  $125^\circ\text{C}$ . The SN74ALS299 is characterized for operation from  $0^\circ\text{C}$  to  $70^\circ\text{C}$ .

SN54ALS299 . . . J PACKAGE  
SN74ALS299 . . . DW OR N PACKAGE  
(TOP VIEW)

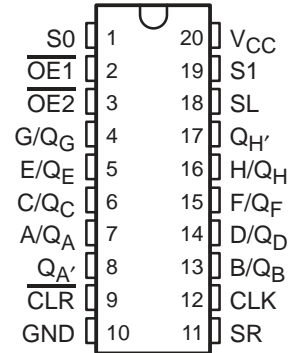

SN54ALS299 . . . FK PACKAGE  
(TOP VIEW)

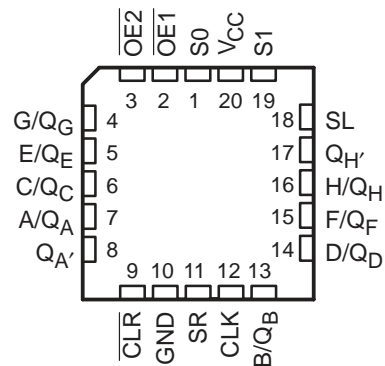

# SN54ALS299, SN74ALS299 8-BIT UNIVERSAL SHIFT/STORAGE REGISTERS WITH 3-STATE OUTPUTS

SDAS220B – DECEMBER 1982 – REVISED DECEMBER 1994

FUNCTION TABLE

MODE	INPUTS								I/O PORTS								OUTPUTS			
	CLR	S1	S0	OE1†	OE2†	CLK	SL	SR	A/QA	B/QB	C/QC	D/QD	E/QE	F/QF	G/QG	H/QH	QA'	QH'		
Clear	L	X	L	L	L	X	X	X	L	L	L	L	L	L	L	L	L	L	L	L
	L	L	X	L	L	X	X	X	L	L	L	L	L	L	L	L	L	L	L	L
	L	H	H	X	X	X	X	X	X	X	X	X	X	X	X	X	X	X	L	L
Hold	H	L	L	L	L	X	X	X	QA0	QB0	QC0	QD0	QE0	QF0	QG0	QH0	QA0	QH0	QA0	QH0
	H	X	X	L	L	L	X	X	QA0	QB0	QC0	QD0	QE0	QF0	QG0	QH0	QA0	QH0	QA0	QH0
Shift Right	H	L	H	L	L	↑	X	H	H	QA <sub>n</sub>	QB <sub>n</sub>	QC <sub>n</sub>	QD <sub>n</sub>	QE <sub>n</sub>	QF <sub>n</sub>	QG <sub>n</sub>	H	QH <sub>n</sub>	H	QH <sub>n</sub>
	H	L	H	L	L	↑	X	L	L	QA <sub>n</sub>	QB <sub>n</sub>	QC <sub>n</sub>	QD <sub>n</sub>	QE <sub>n</sub>	QF <sub>n</sub>	QG <sub>n</sub>	L	QH <sub>n</sub>	L	QH <sub>n</sub>
Shift Left	H	H	L	L	L	↑	H	X	QB <sub>n</sub>	QC <sub>n</sub>	QD <sub>n</sub>	QE <sub>n</sub>	QF <sub>n</sub>	QG <sub>n</sub>	QH <sub>n</sub>	H	QB <sub>n</sub>	H	QB <sub>n</sub>	H
	H	H	L	L	L	↑	L	X	QB <sub>n</sub>	QC <sub>n</sub>	QD <sub>n</sub>	QE <sub>n</sub>	QF <sub>n</sub>	QG <sub>n</sub>	QH <sub>n</sub>	L	QB <sub>n</sub>	L	QB <sub>n</sub>	L
Load	H	H	H	X	X	↑	X	X	a	b	c	d	e	f	g	h	a	h	a	h

NOTE: a . . . h = the level of the steady-state input at inputs A through H, respectively. This data is loaded into the flip-flops while the flip-flop outputs are isolated from the I/O terminals.

† When one or both output-enable inputs are high, the eight I/O terminals are disabled to the high-impedance state; however, sequential operation or clearing of the register is not affected.

## logic symbol‡

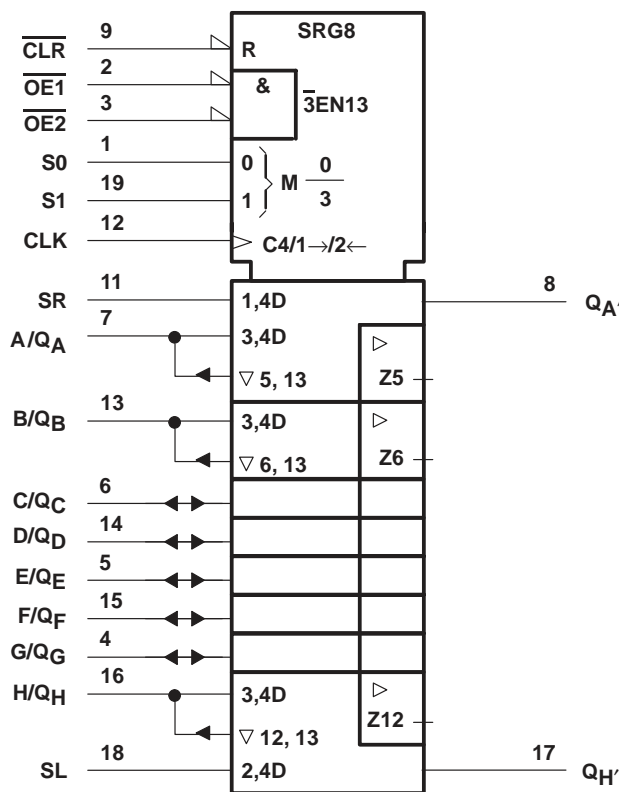

‡ This symbol is in accordance with ANSI/IEEE Std 91-1984 and IEC Publication 617-12.

# SN54ALS299, SN74ALS299 8-BIT UNIVERSAL SHIFT/STORAGE REGISTERS WITH 3-STATE OUTPUTS

SDAS220B – DECEMBER 1982 – REVISED DECEMBER 1994

## logic diagram (positive logic)

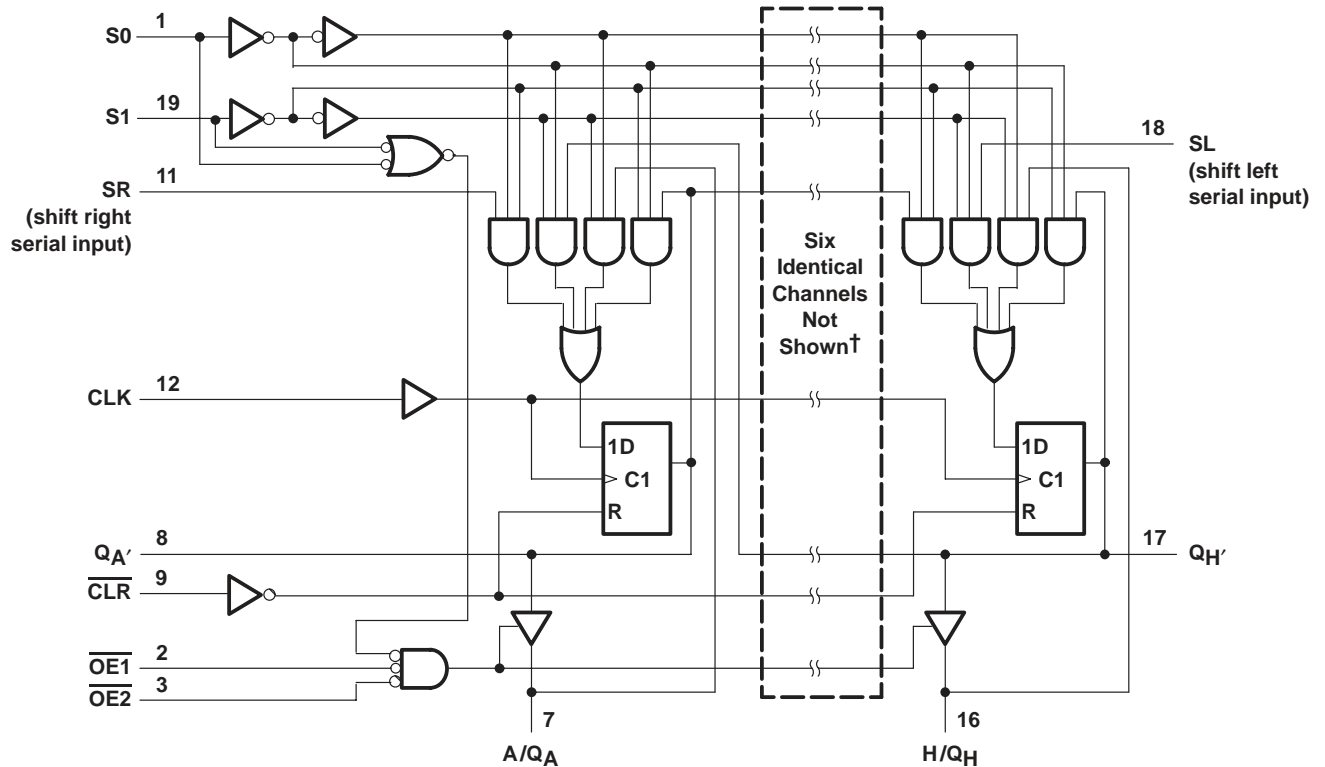

† I/O ports not shown: B/Q<sub>B</sub> (13), C/Q<sub>C</sub> (6), D/Q<sub>D</sub> (14), E/Q<sub>E</sub> (5), F/Q<sub>F</sub> (15), and G/Q<sub>G</sub> (4).

## absolute maximum ratings over operating free-air temperature range (unless otherwise noted)‡

Supply voltage, $V_{CC}$	7 V
Input voltage, $V_I$ : All inputs	7 V
I/O ports	5.5 V
Operating free-air temperature range, $T_A$ : SN54ALS299	-55°C to 125°C
SN74ALS299	0°C to 70°C
Storage temperature range	-65°C to 150°C

‡ Stresses beyond those listed under "absolute maximum ratings" may cause permanent damage to the device. These are stress ratings only, and functional operation of the device at these or any other conditions beyond those indicated under "recommended operating conditions" is not implied. Exposure to absolute-maximum-rated conditions for extended periods may affect device reliability.

# SN54ALS299, SN74ALS299

## 8-BIT UNIVERSAL SHIFT/STORAGE REGISTERS

### WITH 3-STATE OUTPUTS

SDAS220B – DECEMBER 1982 – REVISED DECEMBER 1994

#### recommended operating conditions

		SN54ALS299			SN74ALS299			UNIT
		MIN	NOM	MAX	MIN	NOM	MAX	
$V_{CC}$	Supply voltage	4.5	5	5.5	4.5	5	5.5	V
$V_{IH}$	High-level input voltage	2			2			V
$V_{IL}$	Low-level input voltage			0.7			0.8	V
$I_{OH}$	High-level output current	$Q_A'$ or $Q_H'$		-0.4		-0.4		mA
		$Q_A - Q_H$		-1		-2.6		
$I_{OL}$	Low-level output current	$Q_A'$ or $Q_H'$		4		8		mA
		$Q_A - Q_H$		12		24		
$T_A$	Operating free-air temperature	-55		125	0		70	°C

#### electrical characteristics over recommended operating free-air temperature range (unless otherwise noted)

PARAMETER		TEST CONDITIONS		SN54ALS299		SN74ALS299		UNIT
				MIN	TYP†	MAX	MIN	
$V_{IK}$		$V_{CC} = 4.5\text{ V}$ ,	$I_I = -18\text{ mA}$			-1.5	-1.5	V
$V_{OH}$	All outputs	$V_{CC} = 4.5\text{ V to } 5.5\text{ V}$ ,	$I_{OH} = -0.4\text{ mA}$	$V_{CC} - 2$		$V_{CC} - 2$		V
	$Q_A - Q_H$	$V_{CC} = 4.5\text{ V}$	$I_{OH} = -1\text{ mA}$	2.4	3.3			
$V_{OL}$	$Q_A'$ or $Q_H'$	$V_{CC} = 4.5\text{ V}$	$I_{OL} = 4\text{ mA}$	0.25	0.4	0.25	0.4	V
			$I_{OL} = 8\text{ mA}$			0.35	0.5	
	$Q_A - Q_H$	$V_{CC} = 4.5\text{ V}$	$I_{OL} = 12\text{ mA}$	0.25	0.4	0.25	0.4	
			$I_{OL} = 24\text{ mA}$			0.35	0.5	
$I_I$	A – H	$V_{CC} = 5.5\text{ V}$	$V_I = 5.5\text{ V}$			0.1	0.1	mA
	Any others		$V_I = 7\text{ V}$			0.1	0.1	
$I_{IH}‡$		$V_{CC} = 5.5\text{ V}$ ,	$V_I = 2.7\text{ V}$			20	20	µA
$I_{IL}‡$	S0, S1, SR, SL	$V_{CC} = 5.5\text{ V}$ ,	$V_I = 0.4\text{ V}$			-0.2	-0.2	mA
	Any others					-0.1	-0.1	
$I_{OS}§$	$Q_A'$ or $Q_H'$	$V_{CC} = 5.5\text{ V}$ ,	$V_O = 2.25\text{ V}$	-15	-70	-15	-70	mA
	$Q_A - Q_H$			-20	-112	-30	-112	
$I_{CC}$		$V_{CC} = 5.5\text{ V}$	Outputs high	15	28	15	28	mA
			Outputs low	22	38	22	38	
			Outputs disabled	23	40	23	40	

† All typical values are at  $V_{CC} = 5\text{ V}$ ,  $T_A = 25^\circ\text{C}$ .

‡ For I/O ports ( $Q_A - Q_H$ ), the parameters  $I_{IH}$  and  $I_{IL}$  include the off-state output current.

§ The output conditions have been chosen to produce a current that closely approximates one half of the true short-circuit output current,  $I_{OS}$ .

# SN54ALS299, SN74ALS299 8-BIT UNIVERSAL SHIFT/STORAGE REGISTERS WITH 3-STATE OUTPUTS

SDAS220B – DECEMBER 1982 – REVISED DECEMBER 1994

timing requirements over recommended ranges of supply voltage and operating free-air temperature (unless otherwise noted)

		SN54ALS299		SN74ALS299		UNIT
		MIN	MAX	MIN	MAX	
$f_{\text{clock}}$	Clock frequency (at 50% duty cycle)	0	17	0	30	MHz
$t_w$	Pulse duration	CLK high or low		16.5		ns
		CLR low		10		
$t_{\text{su}}$	Setup time before CLK $\uparrow$	S0 or S1		20		ns
		Serial or parallel data	High	16		
	Low		6			
	Inactive-state setup time before CLK $\uparrow$ $\dagger$	CLR		15		
$t_h$	Hold time after CLK $\uparrow$	S0 or S1		0		ns
		Serial or parallel data		0		

$\dagger$  Inactive-state setup time is also referred to as recovery time.

## switching characteristics (see Figure 1)

PARAMETER	FROM (INPUT)	TO (OUTPUT)	V <sub>CC</sub> = 4.5 V to 5.5 V, C <sub>L</sub> = 50 pF, R <sub>1</sub> = 500 $\Omega$ , R <sub>2</sub> = 500 $\Omega$ , T <sub>A</sub> = MIN to MAX $\ddagger$				UNIT
			SN54ALS299		SN74ALS299		
			MIN	MAX	MIN	MAX	
$f_{\text{max}}$			17		30	MHz	
$t_{\text{PLH}}$	CLK	Q <sub>A</sub> –Q <sub>H</sub>	2	19	4	13	ns
$t_{\text{PHL}}$			4	25	7	19	
$t_{\text{PLH}}$	CLK	Q <sub>A'</sub> or Q <sub>H'</sub>	2	21	5	15	ns
$t_{\text{PHL}}$			4	25	8	18	
$t_{\text{PHL}}$	CLR	Q <sub>A</sub> –Q <sub>H</sub>	6	29	6	22	ns
		Q <sub>A'</sub> or Q <sub>H'</sub>	6	29	6	22	
$t_{\text{PZH}}$	OE1, OE2	Q <sub>A</sub> –Q <sub>H</sub>	5	22	6	16	ns
$t_{\text{PZL}}$			6	27	8	22	
$t_{\text{PZH}}$	S0, S1	Q <sub>A</sub> –Q <sub>H</sub>	5	27	7	17	ns
$t_{\text{PZL}}$			6	26	8	22	
$t_{\text{PHZ}}$	OE1, OE2	Q <sub>A</sub> –Q <sub>H</sub>	1	15	1	8	ns
$t_{\text{PLZ}}$			4	38	5	15	
$t_{\text{PHZ}}$	S0, S1	Q <sub>A</sub> –Q <sub>H</sub>	1	16	1	12	ns
$t_{\text{PLZ}}$			4	34	8	25	

$\ddagger$  For conditions shown as MIN or MAX, use the appropriate value specified under recommended operating conditions.

# SN54ALS299, SN74ALS299 8-BIT UNIVERSAL SHIFT/STORAGE REGISTERS WITH 3-STATE OUTPUTS

SDAS220B – DECEMBER 1982 – REVISED DECEMBER 1994

## PARAMETER MEASUREMENT INFORMATION SERIES 54ALS/74ALS AND 54AS/74AS DEVICES

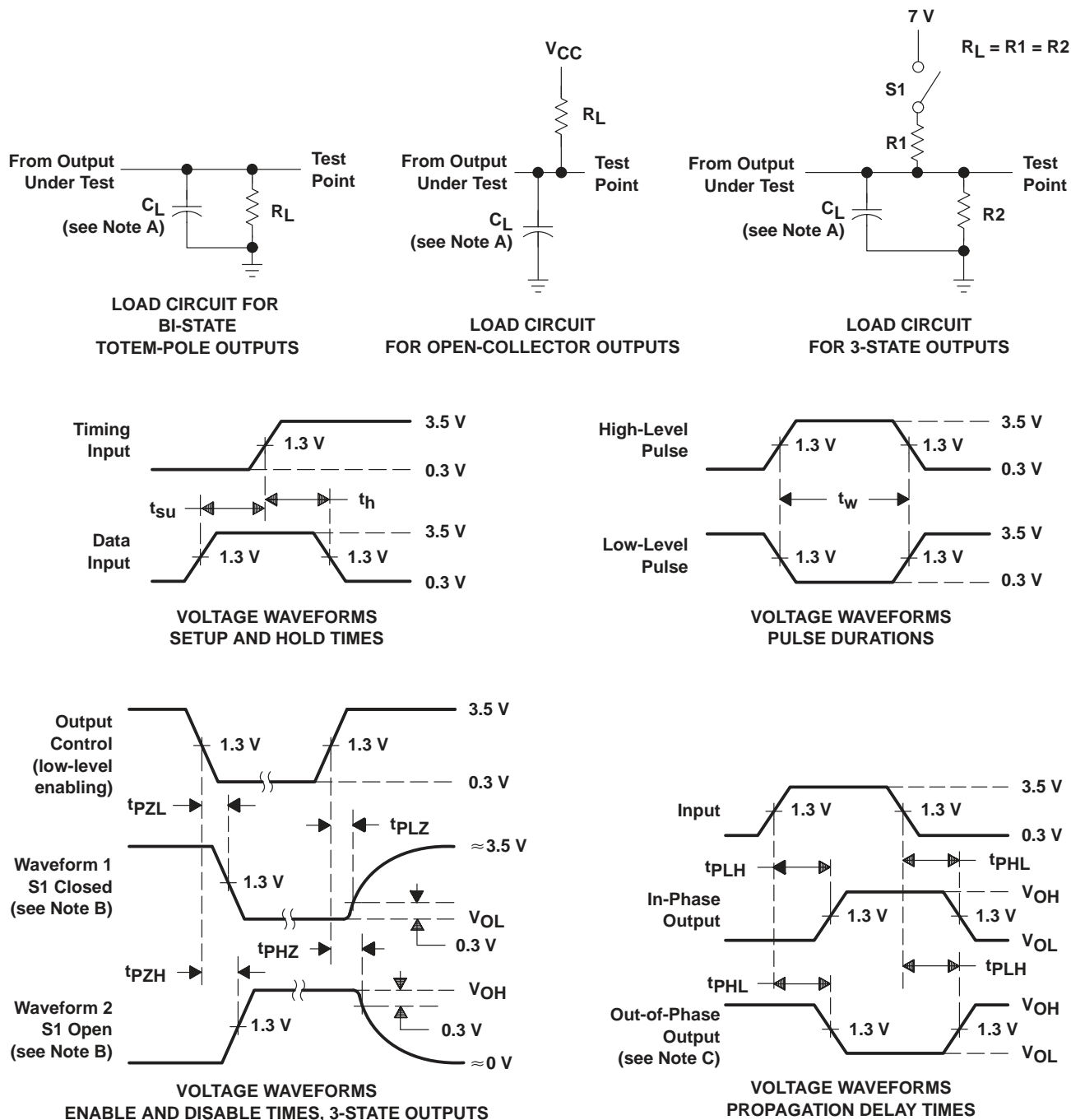

- NOTES: A.  $C_L$  includes probe and jig capacitance.  
 B. Waveform 1 is for an output with internal conditions such that the output is low except when disabled by the output control. Waveform 2 is for an output with internal conditions such that the output is high except when disabled by the output control.  
 C. When measuring propagation delay items of 3-state outputs, switch S1 is open.  
 D. All input pulses have the following characteristics:  $PRR \leq 1$  MHz,  $t_r = t_f = 2$  ns, duty cycle = 50%.  
 E. The outputs are measured one at a time with one transition per measurement.

Figure 1. Load Circuits and Voltage Waveforms

**PACKAGING INFORMATION**

Orderable Device	Status (1)	Package Type	Package Drawing	Pins	Package Qty	Eco Plan (2)	Lead finish/ Ball material (6)	MSL Peak Temp (3)	Op Temp (°C)	Device Marking (4/5)	Samples
83021012A	ACTIVE	LCCC	FK	20	1	Non-RoHS & Green	SNPB	N / A for Pkg Type	-55 to 125	83021012A SNJ54ALS 299FK	<a href="#">Samples</a>
8302101RA	ACTIVE	CDIP	J	20	1	Non-RoHS & Green	SNPB	N / A for Pkg Type	-55 to 125	8302101RA SNJ54ALS299J	<a href="#">Samples</a>
8302101SA	ACTIVE	CFP	W	20	1	Non-RoHS & Green	SNPB	N / A for Pkg Type	-55 to 125	8302101SA SNJ54ALS299W	<a href="#">Samples</a>
SN74ALS299DW	ACTIVE	SOIC	DW	20	25	RoHS & Green	NIPDAU	Level-1-260C-UNLIM	0 to 70	ALS299	<a href="#">Samples</a>
SN74ALS299N	ACTIVE	PDIP	N	20	20	RoHS & Non-Green	NIPDAU	N / A for Pkg Type	0 to 70	SN74ALS299N	<a href="#">Samples</a>
SNJ54ALS299FK	ACTIVE	LCCC	FK	20	1	Non-RoHS & Green	SNPB	N / A for Pkg Type	-55 to 125	83021012A SNJ54ALS 299FK	<a href="#">Samples</a>
SNJ54ALS299J	ACTIVE	CDIP	J	20	1	Non-RoHS & Green	SNPB	N / A for Pkg Type	-55 to 125	8302101RA SNJ54ALS299J	<a href="#">Samples</a>
SNJ54ALS299W	ACTIVE	CFP	W	20	1	Non-RoHS & Green	SNPB	N / A for Pkg Type	-55 to 125	8302101SA SNJ54ALS299W	<a href="#">Samples</a>

(1) The marketing status values are defined as follows:

**ACTIVE:** Product device recommended for new designs.

**LIFEBUY:** TI has announced that the device will be discontinued, and a lifetime-buy period is in effect.

**NRND:** Not recommended for new designs. Device is in production to support existing customers, but TI does not recommend using this part in a new design.

**PREVIEW:** Device has been announced but is not in production. Samples may or may not be available.

**OBSOLETE:** TI has discontinued the production of the device.

(2) **RoHS:** TI defines "RoHS" to mean semiconductor products that are compliant with the current EU RoHS requirements for all 10 RoHS substances, including the requirement that RoHS substance do not exceed 0.1% by weight in homogeneous materials. Where designed to be soldered at high temperatures, "RoHS" products are suitable for use in specified lead-free processes. TI may reference these types of products as "Pb-Free".

**RoHS Exempt:** TI defines "RoHS Exempt" to mean products that contain lead but are compliant with EU RoHS pursuant to a specific EU RoHS exemption.

**Green:** TI defines "Green" to mean the content of Chlorine (Cl) and Bromine (Br) based flame retardants meet JS709B low halogen requirements of <=1000ppm threshold. Antimony trioxide based flame retardants must also meet the <=1000ppm threshold requirement.

(3) MSL, Peak Temp. - The Moisture Sensitivity Level rating according to the JEDEC industry standard classifications, and peak solder temperature.

(4) There may be additional marking, which relates to the logo, the lot trace code information, or the environmental category on the device.

(5) Multiple Device Markings will be inside parentheses. Only one Device Marking contained in parentheses and separated by a "~" will appear on a device. If a line is indented then it is a continuation of the previous line and the two combined represent the entire Device Marking for that device.

(6) Lead finish/Ball material - Orderable Devices may have multiple material finish options. Finish options are separated by a vertical ruled line. Lead finish/Ball material values may wrap to two lines if the finish value exceeds the maximum column width.

**Important Information and Disclaimer:**The information provided on this page represents TI's knowledge and belief as of the date that it is provided. TI bases its knowledge and belief on information provided by third parties, and makes no representation or warranty as to the accuracy of such information. Efforts are underway to better integrate information from third parties. TI has taken and continues to take reasonable steps to provide representative and accurate information but may not have conducted destructive testing or chemical analysis on incoming materials and chemicals. TI and TI suppliers consider certain information to be proprietary, and thus CAS numbers and other limited information may not be available for release.

In no event shall TI's liability arising out of such information exceed the total purchase price of the TI part(s) at issue in this document sold by TI to Customer on an annual basis.

**OTHER QUALIFIED VERSIONS OF SN54ALS299, SN74ALS299 :**

- Catalog : [SN74ALS299](#)
- Military : [SN54ALS299](#)

NOTE: Qualified Version Definitions:

- Catalog - TI's standard catalog product
- Military - QML certified for Military and Defense Applications



**TUBE**

\*All dimensions are nominal

Device	Package Name	Package Type	Pins	SPQ	L (mm)	W (mm)	T (μm)	B (mm)
83021012A	FK	LCCC	20	1	506.98	12.06	2030	NA
8302101SA	W	CFP	20	1	506.98	26.16	6220	NA
SN74ALS299DW	DW	SOIC	20	25	507	12.83	5080	6.6
SN74ALS299N	N	PDIP	20	20	506	13.97	11230	4.32
SNJ54ALS299FK	FK	LCCC	20	1	506.98	12.06	2030	NA
SNJ54ALS299W	W	CFP	20	1	506.98	26.16	6220	NA

N (R-PDIP-T\*\*)

PLASTIC DUAL-IN-LINE PACKAGE

16 PINS SHOWN



- NOTES:
- A. All linear dimensions are in inches (millimeters).
  - B. This drawing is subject to change without notice.
  - Falls within JEDEC MS-001, except 18 and 20 pin minimum body length (Dim A).
  - The 20 pin end lead shoulder width is a vendor option, either half or full width.

# DW0020A



# PACKAGE OUTLINE

## SOIC - 2.65 mm max height

SOIC

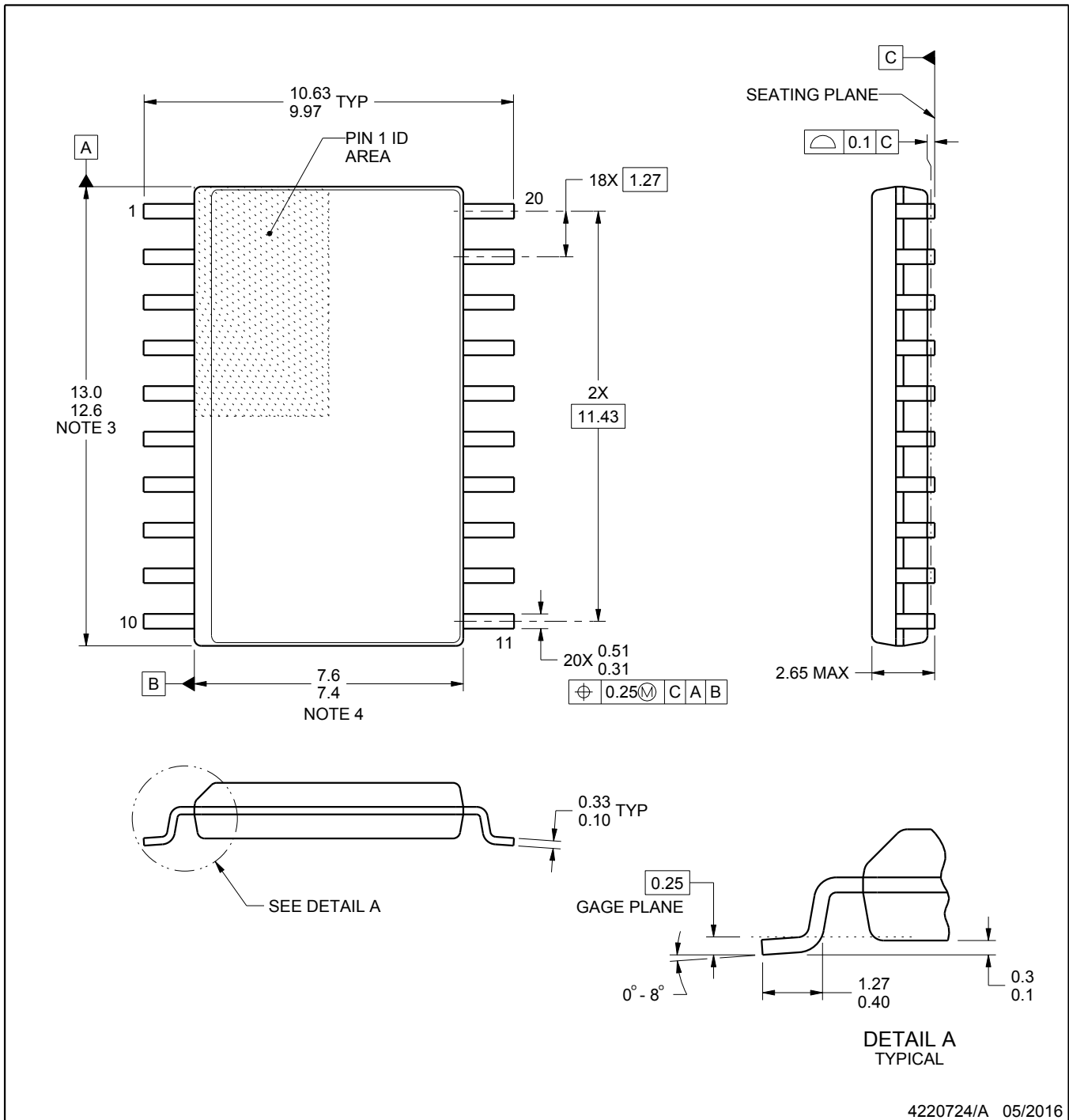

4220724/A 05/2016

**NOTES:**

1. All linear dimensions are in millimeters. Dimensions in parenthesis are for reference only. Dimensioning and tolerancing per ASME Y14.5M.
2. This drawing is subject to change without notice.
3. This dimension does not include mold flash, protrusions, or gate burrs. Mold flash, protrusions, or gate burrs shall not exceed 0.15 mm per side.
4. This dimension does not include interlead flash. Interlead flash shall not exceed 0.43 mm per side.
5. Reference JEDEC registration MS-013.

# EXAMPLE BOARD LAYOUT

DW0020A

SOIC - 2.65 mm max height

SOIC

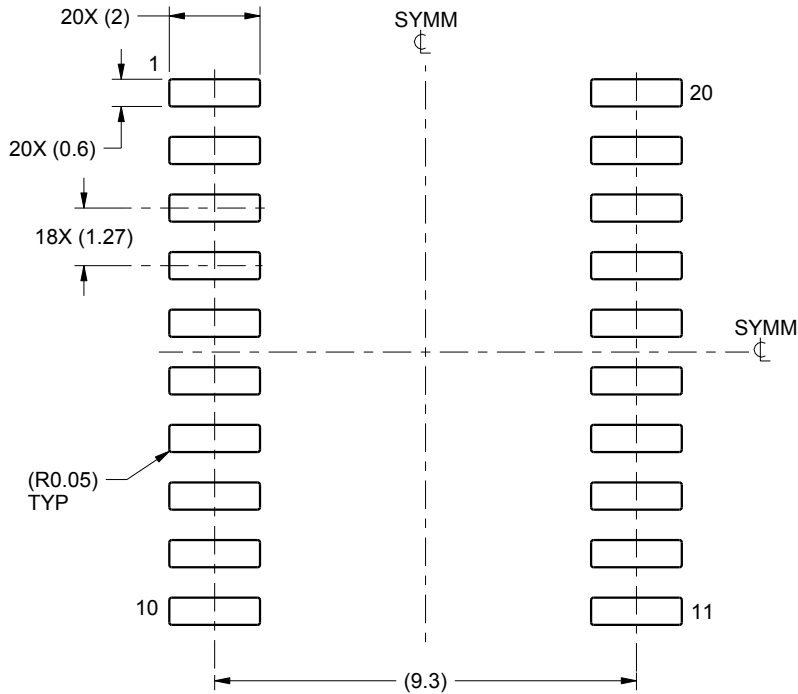

LAND PATTERN EXAMPLE  
SCALE:6X

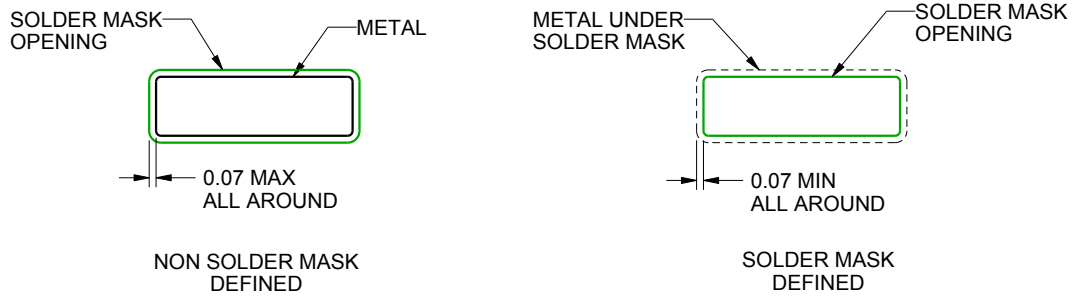

SOLDER MASK DETAILS

4220724/A 05/2016

NOTES: (continued)

- 6. Publication IPC-7351 may have alternate designs.
- 7. Solder mask tolerances between and around signal pads can vary based on board fabrication site.

# EXAMPLE STENCIL DESIGN

DW0020A

SOIC - 2.65 mm max height

SOIC

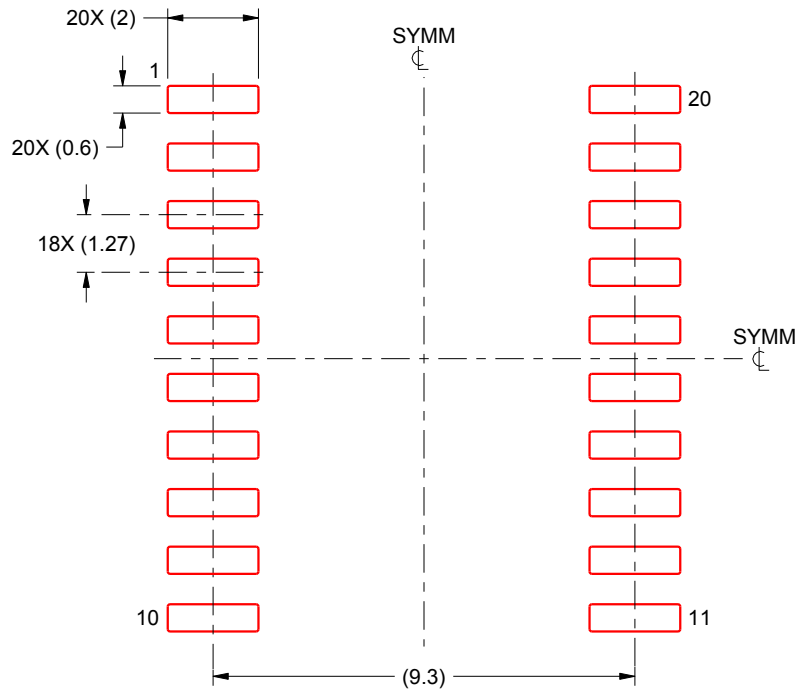

SOLDER PASTE EXAMPLE  
BASED ON 0.125 mm THICK STENCIL  
SCALE:6X

4220724/A 05/2016

NOTES: (continued)

8. Laser cutting apertures with trapezoidal walls and rounded corners may offer better paste release. IPC-7525 may have alternate design recommendations.
9. Board assembly site may have different recommendations for stencil design.

J (R-GDIP-T\*\*)

14 LEADS SHOWN

CERAMIC DUAL IN-LINE PACKAGE

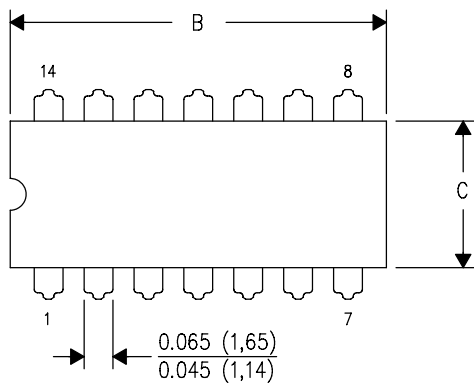

DIM \ PINS **	14	16	18	20
A	0.300 (7,62) BSC	0.300 (7,62) BSC	0.300 (7,62) BSC	0.300 (7,62) BSC
B MAX	0.785 (19,94)	.840 (21,34)	0.960 (24,38)	1.060 (26,92)
B MIN	—	—	—	—
C MAX	0.300 (7,62)	0.300 (7,62)	0.310 (7,87)	0.300 (7,62)
C MIN	0.245 (6,22)	0.245 (6,22)	0.220 (5,59)	0.245 (6,22)

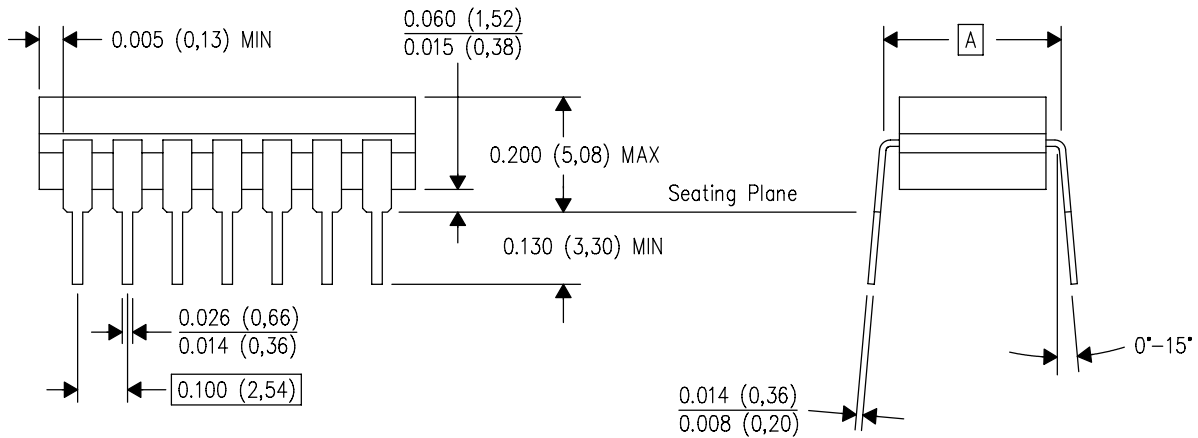

4040083/F 03/03

- NOTES:
- A. All linear dimensions are in inches (millimeters).
  - B. This drawing is subject to change without notice.
  - C. This package is hermetically sealed with a ceramic lid using glass frit.
  - D. Index point is provided on cap for terminal identification only on press ceramic glass frit seal only.
  - E. Falls within MIL STD 1835 GDIP1-T14, GDIP1-T16, GDIP1-T18 and GDIP1-T20.

## GENERIC PACKAGE VIEW

**FK 20**

**LCCC - 2.03 mm max height**

8.89 x 8.89, 1.27 mm pitch

LEADLESS CERAMIC CHIP CARRIER

This image is a representation of the package family, actual package may vary.  
Refer to the product data sheet for package details.

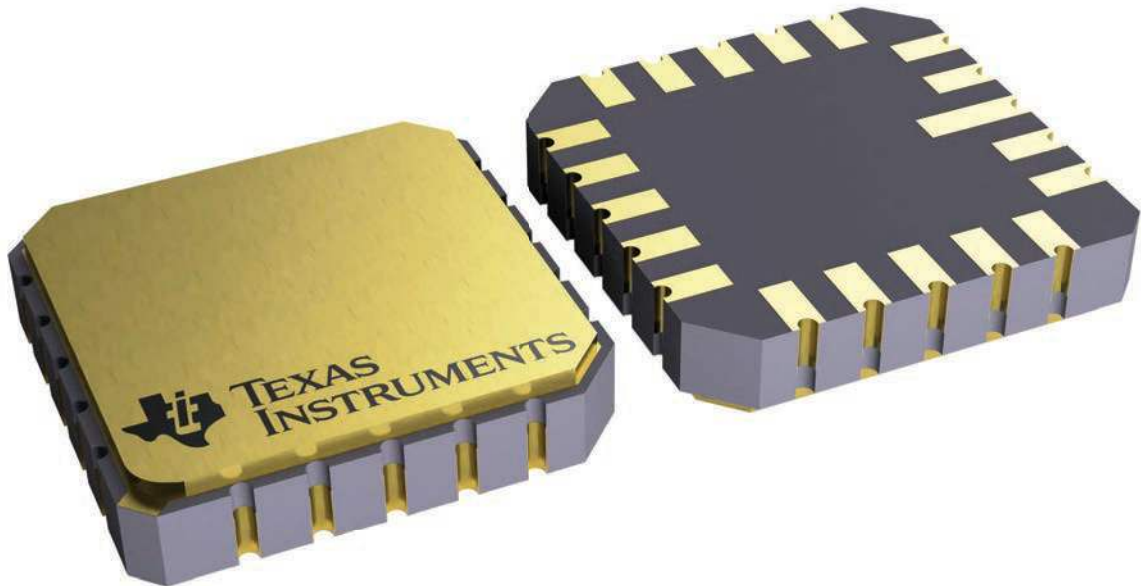

4229370VA\

W (R-GDFP-F20)

CERAMIC DUAL FLATPACK

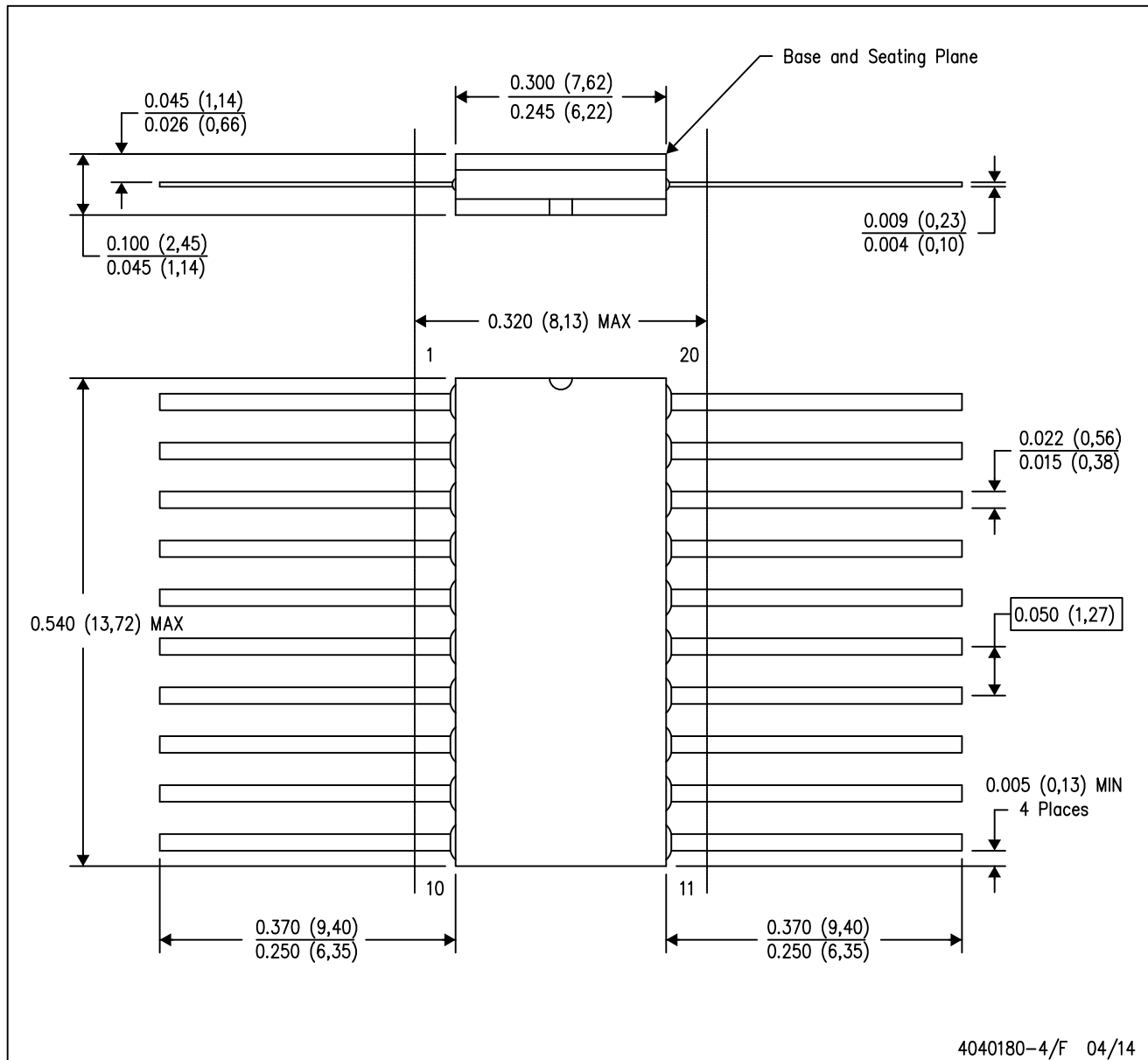

- NOTES:
- All linear dimensions are in inches (millimeters).
  - This drawing is subject to change without notice.
  - This package can be hermetically sealed with a ceramic lid using glass frit.
  - Index point is provided on cap for terminal identification only.
  - Falls within Mil-Std 1835 GDFP2-F20



## IMPORTANT NOTICE AND DISCLAIMER

TI PROVIDES TECHNICAL AND RELIABILITY DATA (INCLUDING DATA SHEETS), DESIGN RESOURCES (INCLUDING REFERENCE DESIGNS), APPLICATION OR OTHER DESIGN ADVICE, WEB TOOLS, SAFETY INFORMATION, AND OTHER RESOURCES "AS IS" AND WITH ALL FAULTS, AND DISCLAIMS ALL WARRANTIES, EXPRESS AND IMPLIED, INCLUDING WITHOUT LIMITATION ANY IMPLIED WARRANTIES OF MERCHANTABILITY, FITNESS FOR A PARTICULAR PURPOSE OR NON-INFRINGEMENT OF THIRD PARTY INTELLECTUAL PROPERTY RIGHTS.

These resources are intended for skilled developers designing with TI products. You are solely responsible for (1) selecting the appropriate TI products for your application, (2) designing, validating and testing your application, and (3) ensuring your application meets applicable standards, and any other safety, security, regulatory or other requirements.

These resources are subject to change without notice. TI grants you permission to use these resources only for development of an application that uses the TI products described in the resource. Other reproduction and display of these resources is prohibited. No license is granted to any other TI intellectual property right or to any third party intellectual property right. TI disclaims responsibility for, and you will fully indemnify TI and its representatives against, any claims, damages, costs, losses, and liabilities arising out of your use of these resources.

TI's products are provided subject to [TI's Terms of Sale](#) or other applicable terms available either on [ti.com](https://www.ti.com) or provided in conjunction with such TI products. TI's provision of these resources does not expand or otherwise alter TI's applicable warranties or warranty disclaimers for TI products.

TI objects to and rejects any additional or different terms you may have proposed.

Mailing Address: Texas Instruments, Post Office Box 655303, Dallas, Texas 75265  
Copyright © 2023, Texas Instruments Incorporated