

SPECIFICATIONS

PARAMETERS	VALUES	UNITS
RATED VOLTAGE	3.5	Vpk
OPERATING VOLTAGE RANGE	3 ~ 5	Vpk
RATED CURRENT (MAX)	35	mA
COIL RESISTANCE	42 ± 6	OHM
MINIMUM SPL @ 10 CM	85	dB
RESONANT FREQUENCY	2,048 ± 500	Hz
OPERATING TEMPERATURE	-20 ~ +70	°C
STORAGE TEMPERATURE	-30 ~ +80	°C
HOUSING MATERIAL	PPO	-
TERMINAL MATERIAL	Au PLATED BRASS	-
WEIGHT	2	grams

THIS DOCUMENT CONTAINS DATA PROPRIETARY TO PUI AUDIO, INC. ANY USE OR REPRODUCTION, IN ANY FORM, WITHOUT PRIOR WRITTEN PERMISSION OF PUI AUDIO, INC. IS PROHIBITED.

©2010, PUI AUDIO Inc.

REVISION HISTORY

LTR	DESCRIPTION	DATE	APPROVED
-	RELEASED FROM ENGINEERING	2014/06/30	
A	ADJUST RATED CURRENT (MAX) TO 35mA	2015/5/7	M.L.

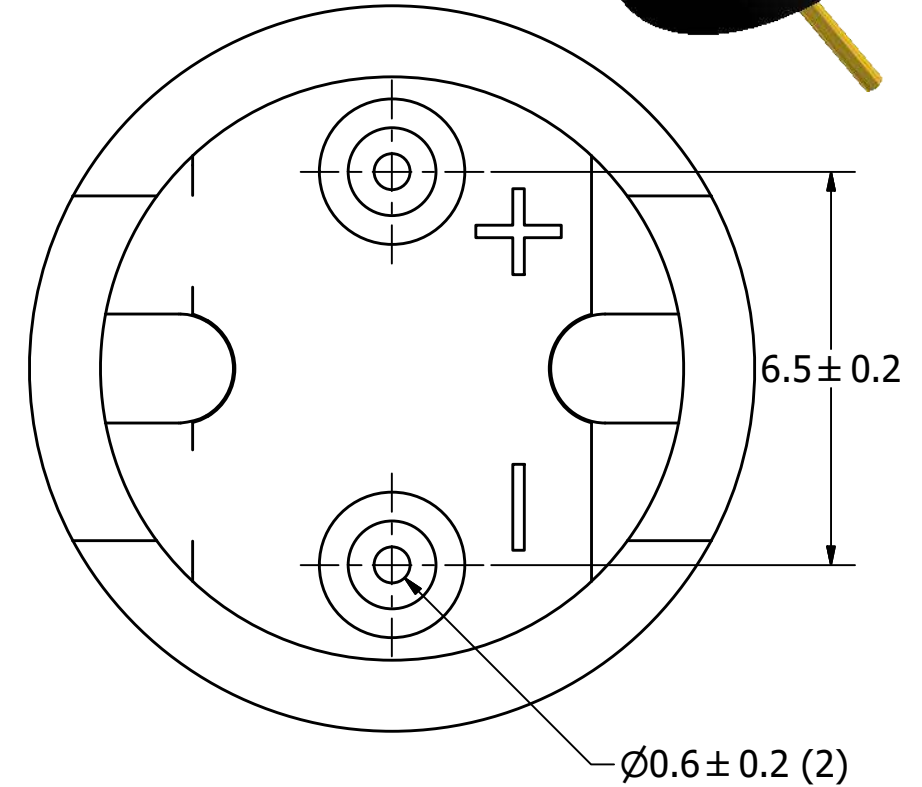
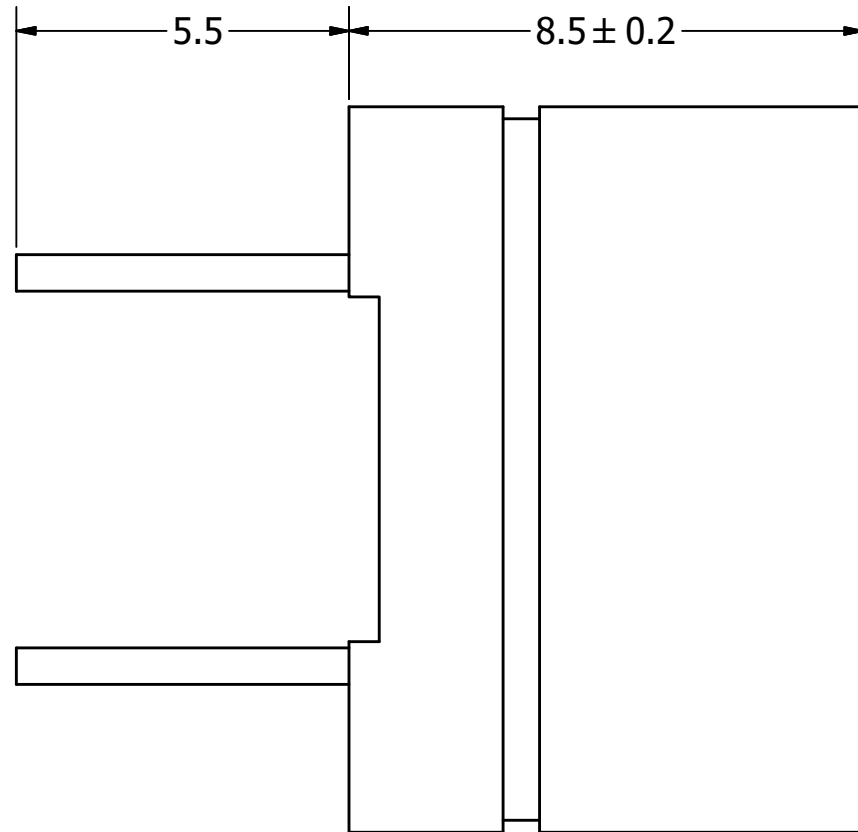
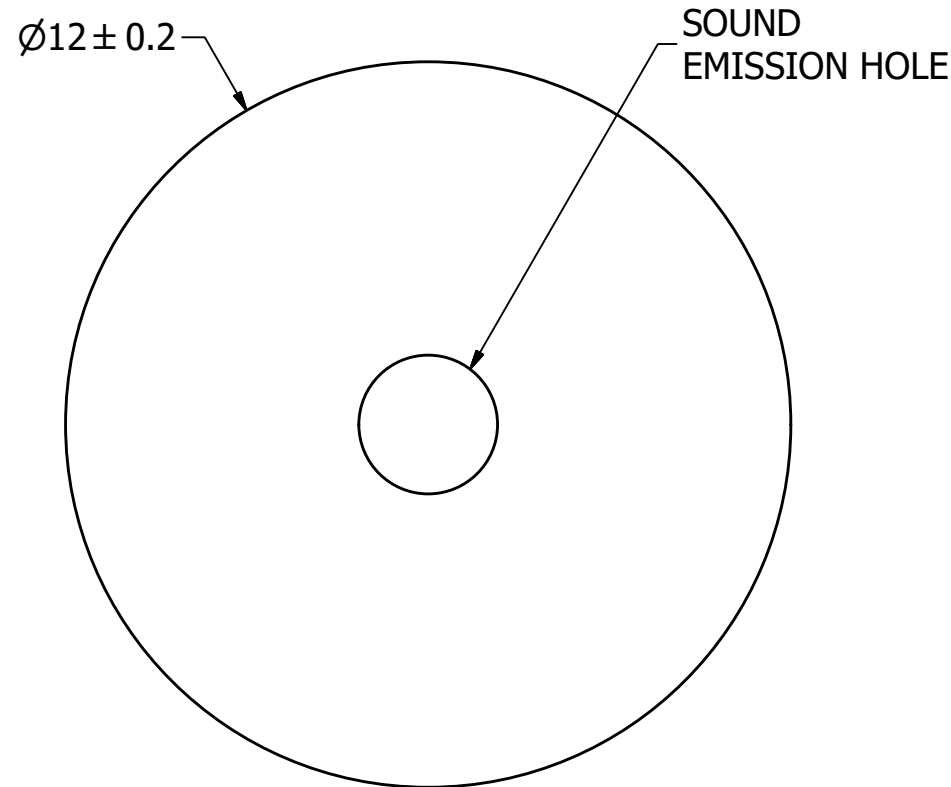
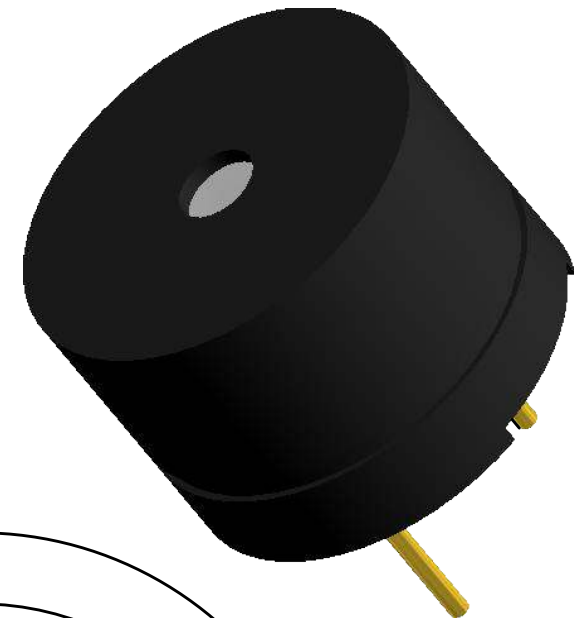

NOTES:

1. ALL DIMENSIONS ARE IN MILLIMETERS.
2. SPECIFICATIONS SUBJECT TO CHANGE OR WITHDRAWL WITHOUT NOTICE.
3. THIS PART IS RoHS 2015/863/EU COMPLIANT.

UNLESS OTHERWISE SPECIFIED:
 ALL PURCHASES ARE SUBJECT TO AND INCORPORATE THE PUI AUDIO TERMS AND CONDITIONS SALE FOUND AT http://www.puiaudio.com/pdf/terms_conditions.pdf (paper copy available upon request).
 DIMENSIONS ARE IN MILLIMETERS, TOLERANCES ARE ±0.5 AND ANGLES ARE ±3°.

AT-1220-TT-9-R.idw

SIZE
A3

Designed by	Date	Checked by	Date	Approved by	Date	Drawn Date
J.D.	6/30/2014	C.W.	6/30/2014	B.R.	6/30/2014	6/30/2014



AT-1220-TT-9-R

Transducer (Electro-Mech)	Edition	Sheet
	-	1 / 1