

**BANNER**<sup>®</sup>

the photoelectric specialist

## SMBQS18A Mounting Bracket

*For use with QS18, QS18E, and QS18AF sensors*

### Features

- Die-cast bracket for mounting into 18 mm holes, or in combination with a swivel bracket (such as SMB3018SC, SMB18S, or SMB18C)
- Wrap-around bracket protects sensor against damage
- Accommodates Euro-style QD connectors and cabled versions
- Cabled units tilt  $\pm 8^\circ$  (if side-mounted)
- Metal hex nut, lock washer, and grommet included
- QS18AF mounts from rear (M2.5) or side (M3) using hardware included with sensor
- Provides a low-cost alternative to an all-metal sensor



Insert nut into holes in sensor housing before inserting sensor into bracket



QS18AF model sensor shown; bracket also can be used with other QS18 models

M2.5  
for QS18AF  
Models

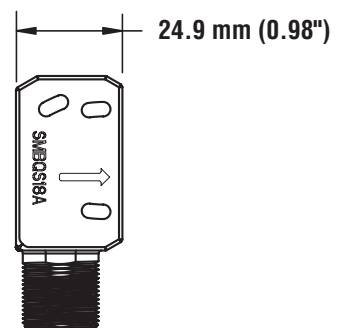
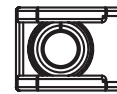
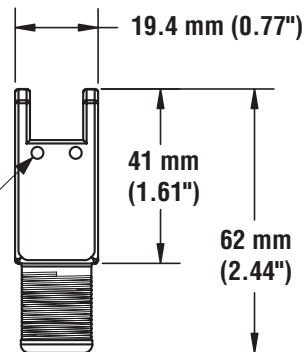

Cable  
Isolation  
Grommet