

# BR2500W - BR2510W

# SILICON BRIDGE RECTIFIERS

**PRV : 50 - 1000 Volts**  
**Io : 25 Amperes**

**FEATURES :**

- \* High current capability
- \* High surge current capability
- \* High reliability
- \* Low reverse current
- \* Low forward voltage drop
- \* High case dielectric strength
- \* Pb / RoHS Free

**MECHANICAL DATA :**

- \* Case : Molded plastic with heatsink integrally mounted in the bridge encapsulation
- \* Epoxy : UL94V-O rate flame retardant
- \* Terminals : Plated lead solderable per MIL-STD-202, Method 208 guaranteed
- \* Polarity : Polarity symbols marked on case
- \* Mounting position : Bolt down on heat-sink with silicone thermal compound between bridge and mounting surface for maximum heat transfer efficiency
- \* Weight : 15.95 grams

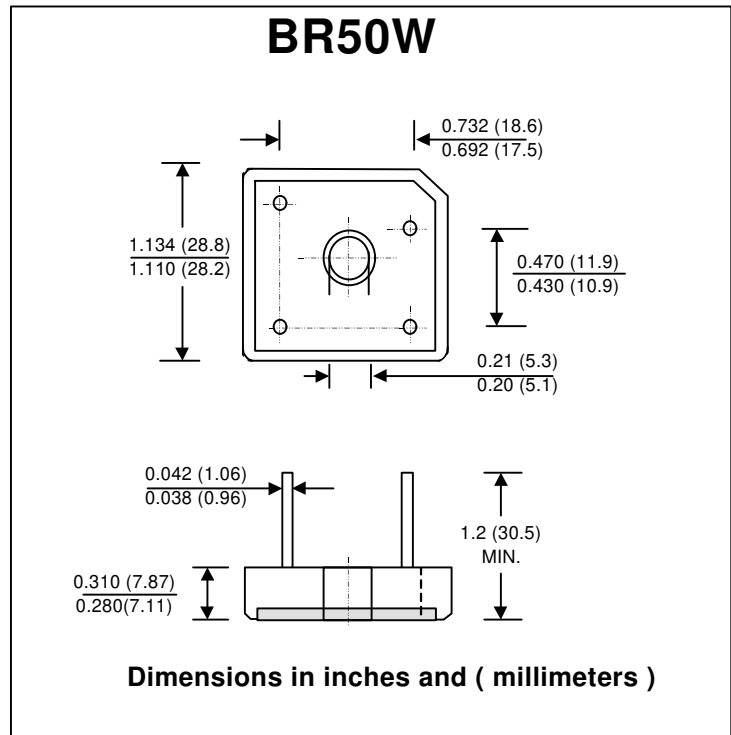

**MAXIMUM RATINGS AND ELECTRICAL CHARACTERISTICS**

Rating at 25 °C ambient temperature unless otherwise specified.  
 Single phase, half wave, 60 Hz, resistive or inductive load.  
 For capacitive load, derate current by 20%.

RATING	SYMBOL	BR 2500W	BR 2501W	BR 2502W	BR 2504W	BR 2506W	BR 2508W	BR 2510W	UNIT
Maximum Recurrent Peak Reverse Voltage	V <sub>RRM</sub>	50	100	200	400	600	800	1000	V
Maximum RMS Voltage	V <sub>RMS</sub>	35	70	140	280	420	560	700	V
Maximum DC Blocking Voltage	V <sub>DC</sub>	50	100	200	400	600	800	1000	V
Maximum Average Forward Current T <sub>c</sub> = 55°C	I <sub>F(AV)</sub>	25							A
Peak Forward Surge Current Single half sine wave Superimposed on rated load (JEDEC Method)	I <sub>FSM</sub>	300							A
Current Squared Time at t < 8.3 ms.	I <sup>2</sup> t	375							A <sup>2</sup> S
Maximum Forward Voltage per Diode at 12.5 A	V <sub>F</sub>	1.1							V
Maximum DC Reverse Current Ta = 25 °C at Rated DC Blocking Voltage Ta = 100 °C	I <sub>R</sub>	10							µA
	I <sub>R(H)</sub>	1.0							mA
Typical Thermal Resistance at Junction to Case ( Note 1 )	R <sub>θJC</sub>	2							°C/W
Typical Thermal Resistance at Junction to Ambient	R <sub>θJA</sub>	22							°C/W
Operating Junction Temperature Range	T <sub>J</sub>	- 40 to + 150							°C
Storage Temperature Range	T <sub>STG</sub>	- 40 to + 150							°C

**Notes :**

1 ) Thermal resistance from Junction to Case with units mounted on a 5" x 4" x 3" ( 12.7 x 10.2 x 7.3 cm ) Al.-wing plate.



### RATING AND CHARACTERISTIC CURVES ( BR2500W - BR2510W )

**FIG.1 - DERATING CURVE FOR OUTPUT RECTIFIED CURRENT**

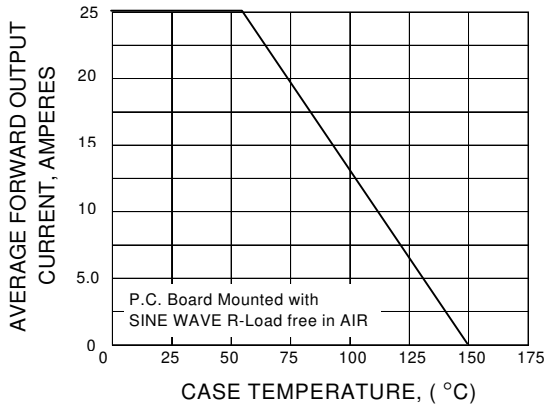

**FIG.2 - MAXIMUM NON-REPETITIVE PEAK FORWARD SURGE CURRENT**

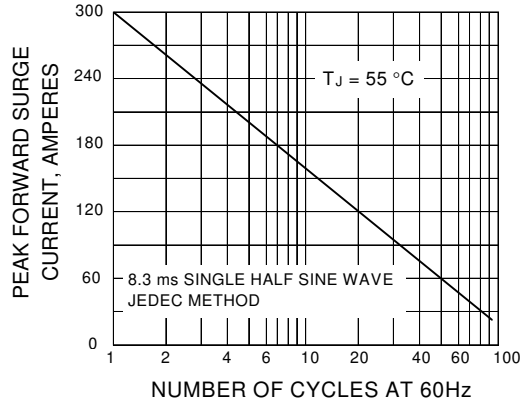

**FIG.3 - TYPICAL FORWARD CHARACTERISTICS**

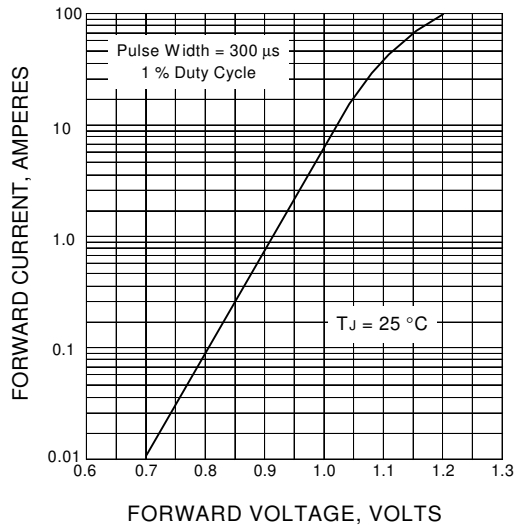

**FIG.4 - TYPICAL REVERSE CHARACTERISTICS**

