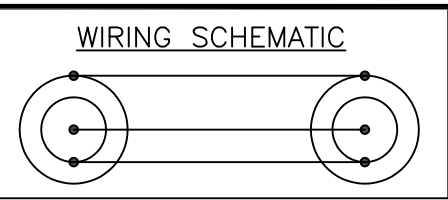
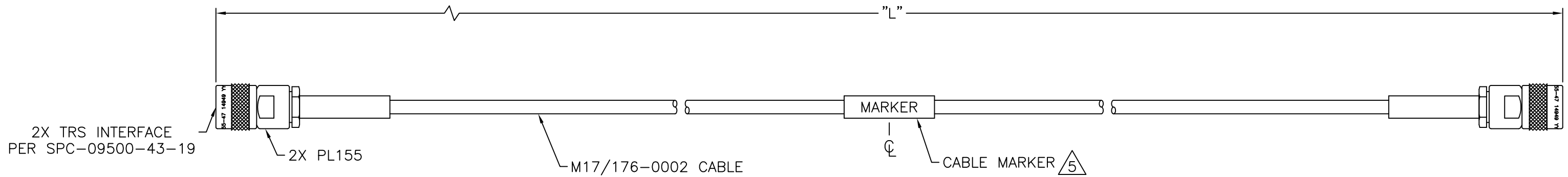

TABLE 1		
MODEL NUMBER	"L"	MARKER 
21-17-12	12	21-17-12 14949 #####
21-17-24	24	21-17-24 14949 #####
21-17-36	36	21-17-36 14949 #####
21-17-60	60	21-17-60 14949 #####
21-17-120	120	21-17-120 14949 #####



REV	ECO	DATE
001	57217	2/12/2019

UNRELEASED ECO
FOR MARKETING
APRIL 30, 2019



NOTES: UNLESS OTHERWISE SPECIFIED.



1. WORKMANSHIP PER IPC/WHMA-A-620, CLASS 3, SECTION 13.

 TOLERANCE PER IPC/WHMA-A-620, SECTION 11.1

3. TESTING:
3.1 CONTINUITY
3.2 DWV: 1000 VRMS

4. BEND RADIUS (MIN): .75

 MARKERS:
5.1 MARKER PER TABLE 1.
5.2 ##### = LOT CODE

 <small>This PROPRIETARY Document is property of Cinch Connectivity Solutions. It is confidential in nature, non-transferable, and issued with the clear understanding that it is not to be traced or copied without permission and is returnable upon demand.</small> <small>INTERPRET DRAWING ACCORDANCE WITH ASME Y14.5-2009.</small>	Model No.	21-17	Title: TROMPETER	
	RoHS2	2011/65/EU	Cage Code	14949
	UNLESS OTHERWISE SPECIFIED	UNITS: INCH	3RD ANGLE PROJECTION	
			Drawn By:	M. Souriphong
		Date:	2/19/2019	Drawing No. C_21-17 Rev. 001 SIZE B DO NOT SCALE DRAWING Workmanship Std. SEE NOTES SHEET 1 OF 1