

LED06W-LT Series

Line Voltage Dimmable

select SYNC classic

Electrical Specifications

Input Voltage Range:	120V model: 108-132V Min/Max 230V model: 208-300V Min/Max
Frequency:	50/60 Hz Nom. (47-63 Hz Min/Max)
Power Factor:	>0.90 @ full load, 120Vac (no dimmer)
Inrush Current:	<10.0 Amps @ 120Vac, cold start 25°C, max load
Input Current (Max):	0.11 Amps @ 120Vac, 60Hz, max load 0.06 Amps @ 230Vac, 60Hz, max load
Maximum Power:	6W
Line Regulation:	± 3%
Load Regulation:	± 5%
THD:	≤20% @ full load (no dimmer)
Start-up Time:	0.7 seconds

Protections

Over-voltage	Output
Over-current	Output
Short Circuit	Auto Recovery

Environmental Specifications

Max Case Life Temp: (5 year warranty)	70°C
Maximum Case Temp (UL):	90°C
Minimum Starting Temp:	-30°C
Storage Temperature:	-40°C to +85°C
Humidity:	5% to 95%
Cooling:	Convection
Vibration Frequency:	5 to 55 Hz/2g, 30 minutes
Sound Rating:	Class A
Impact Resistance:	1g/s
Lifetime:	50,000 hrs @ Tc=71°C (see graph for details)
MTBF:	402,000 Hours @ full load, 40°C ambient conditions per MIL-217F Notice 2
EMC:	FCC 47CFR Part 15 Class B compliant
Weight:	4.5 oz. (128 g)

- Total Power: 6 Watts
- 0%-100% (depends on dimmer control)
- Input Voltage: 120Vac or 230-277Vac Phase Dimming
- UL Dry & Damp Location Rated
- UL Type HL Rated for Hazardous Locations
- IP66 & NEMA4
- Black Magic Thermal Advantage™ Plastic Housing
- Compatible with Triac (leading edge) and ELV (electronic low voltage; trailing edge) dimmer controls
- Use a dimmer that closely matches the load, just slightly larger. (EX: For best performance, use a 150W rated dimmer for 100W total LED load instead of 600W dimmer.)

Note:

LED drivers are designed and intended to operate LED loads only. Non-LED loading may be outside the specified design limits of our LED drivers, and therefore cannot be covered by any warranty. If you desire to use our LED drivers to operate non-LED loads please contact us to discuss compatibility.



120Vac Input - ELV & Triac Dimming Models

Model	Output Current (mA ±5%)	Output Voltage Range (Vdc)	Max. Output Power (W)	Typical Efficiency
LED06W120-036-C0170-LT	170	22-36	6	82%
LED06W120-030-C0200-LT	200	18-30	6	82%
LED06W120-028-C0220-LT	220	17-28	6	81%
LED06W120-020-C0350-LT	350	12-20	6	81%
LED06W120-014-C0450-LT	450	8-14	6	80%
LED06W120-012-C0500-LT	500	7-12	6	80%

230-277Vac Input - ELV & Triac Dimming Models

Model Number	Output Current (mA ±5%)	Output Voltage Range (Vdc)	Max. Output Power (W)	Typical Efficiency
LED06W230-036-C0170-LT	170	22-36	6	82%
LED06W230-030-C0200-LT	200	18-30	6	82%
LED06W230-028-C0220-LT	220	17-28	6	81%
LED06W230-020-C0350-LT	350	12-20	6	81%
LED06W230-014-C0450-LT	450	8-14	6	80%
LED06W230-012-C0500-LT	500	7-12	6	80%

Class 2: US/Canada

Safety Certification	Standard
UL/CUL	UL8750, UL1310 for UL Class 2 & CAN/CSA C22.2 No. 250.13, UL Type HL
CE	EN 61347-1, EN61347-2-13
EMC Standard	Notes
EN 55015	Conducted emission
EN 61000-3-2	RFE Field Susceptibility test
EN 61000-3-3	Electrical Fast Transient
EN 61000-4-5	Surge Immunity Test, 2 kV; L-N
Energy Star	ANSI/IEEE C62.41.1-2002 and ANSI/IEEE C62.41.2-2002
FCC, 47 CFR Part 15	Class B

Dimensions

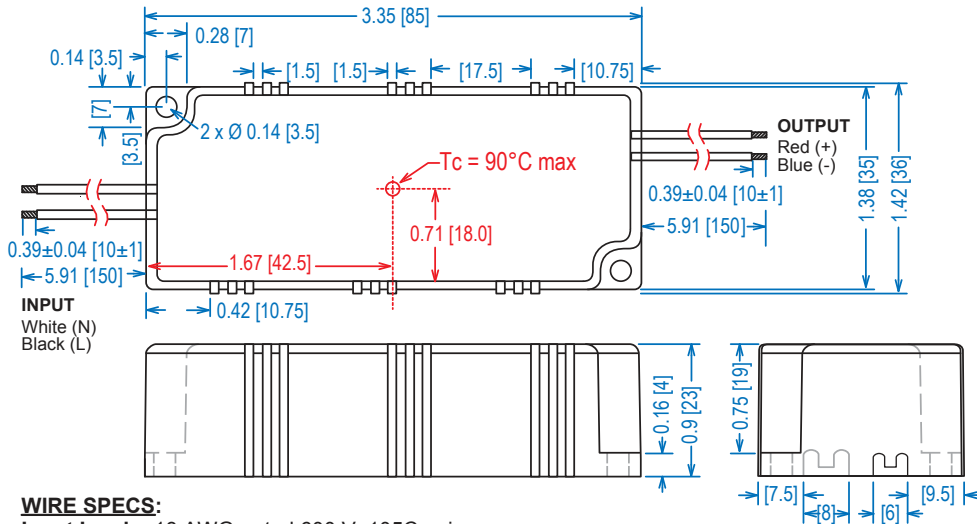

WIRE SPECS:

Input Leads: 18 AWG, rated 600 V, 105C, min.
Output Leads: 18 AWG, rated 300 V, 105C, min.
All wires are stranded with solder dipped ends.

Power Characteristics

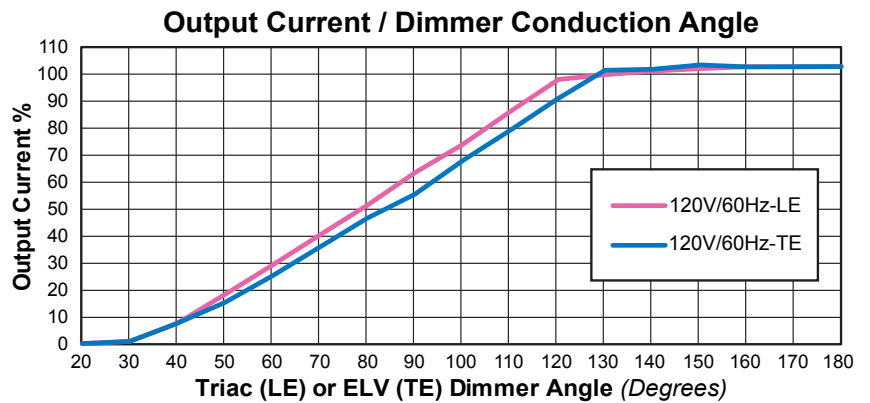
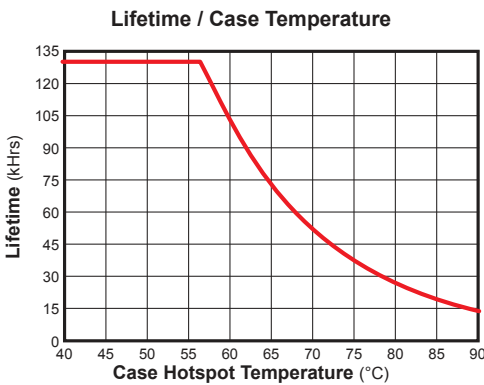
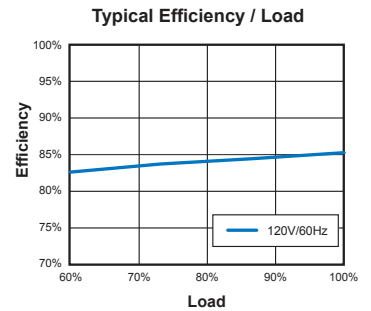
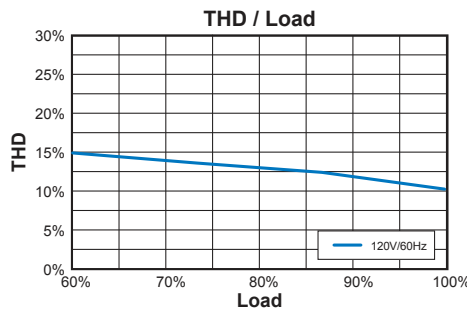
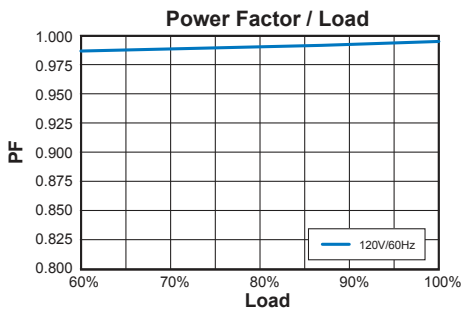

UL Conditions of Acceptability

See website for additional information

Note: The area under the life-temperature curve represents where the driver has highly reliable operation within specification. Driver performance may drift out of published specifications as the hours of operation exceed the curve at a given temperature. Higher operating temperatures increase the chances of a failure to function. Other electrical, mechanical and environmental factors affect driver lifetime but are not represented in this calculation.