

Description

The HXR14400 Transimpedance Linear Amplifier quad channel array is a member of the family of Optical Receiver Transmitter Array (ORTA) products for PAM4 modulation format targeted at the parallel optical links market. Together with a PIN detector array or discrete detectors, high capacity, high availability optical link can be designed for the next generation Ethernet and Datacom applications.

The 3.3V SiGe device integrates the linear transimpedance pre-amplifier, the linear post-amplifier and a versatile CML output stage for four optical channels.

Applications

- Next-generation Ethernet optical receiver modules up to SR
- Proprietary multi-channel small form factor optical modules like CFP8 and QSFP56

Features

- High receiver sensitivity for 56Gbps PAM4 signal
- Up to 3 mApp overload
- Independent, per channel RSSI
- Up to 5kΩ typical differential gain
- Up to 500mVppd output voltage swing and adjustable output swing
- Linear operation with internal AGC
- 158mW per channel power consumption
- QSFP56 MSA compliance
- Optimized for isolated and common cathode photo-detector arrays from multiple vendors

Ordering Information

Part	Temp Range	Pin-Package
HXR14400-DNU	-5°C to +95°C	Die 1.650 x 1.850mm

For price, delivery schedules, and to place orders, please contact IDT: www.IDT.com/go/sales

Device Diagram

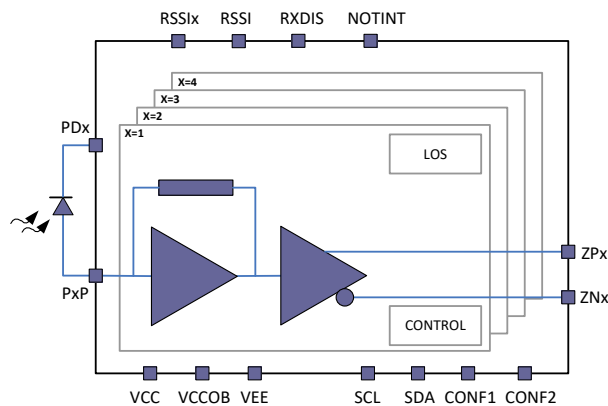

Figure 1: Device diagram

IMPORTANT NOTICE AND DISCLAIMER

RENESAS ELECTRONICS CORPORATION AND ITS SUBSIDIARIES (“RENESAS”) PROVIDES TECHNICAL SPECIFICATIONS AND RELIABILITY DATA (INCLUDING DATASHEETS), DESIGN RESOURCES (INCLUDING REFERENCE DESIGNS), APPLICATION OR OTHER DESIGN ADVICE, WEB TOOLS, SAFETY INFORMATION, AND OTHER RESOURCES “AS IS” AND WITH ALL FAULTS, AND DISCLAIMS ALL WARRANTIES, EXPRESS OR IMPLIED, INCLUDING, WITHOUT LIMITATION, ANY IMPLIED WARRANTIES OF MERCHANTABILITY, FITNESS FOR A PARTICULAR PURPOSE, OR NON-INFRINGEMENT OF THIRD PARTY INTELLECTUAL PROPERTY RIGHTS.

These resources are intended for developers skilled in the art designing with Renesas products. You are solely responsible for (1) selecting the appropriate products for your application, (2) designing, validating, and testing your application, and (3) ensuring your application meets applicable standards, and any other safety, security, or other requirements. These resources are subject to change without notice. Renesas grants you permission to use these resources only for development of an application that uses Renesas products. Other reproduction or use of these resources is strictly prohibited. No license is granted to any other Renesas intellectual property or to any third party intellectual property. Renesas disclaims responsibility for, and you will fully indemnify Renesas and its representatives against, any claims, damages, costs, losses, or liabilities arising out of your use of these resources. Renesas' products are provided only subject to Renesas' Terms and Conditions of Sale or other applicable terms agreed to in writing. No use of any Renesas resources expands or otherwise alters any applicable warranties or warranty disclaimers for these products.

(Disclaimer Rev.1.0 Mar 2020)

Corporate Headquarters

TOYOSU FORESIA, 3-2-24 Toyosu,
Koto-ku, Tokyo 135-0061, Japan
www.renesas.com

Contact Information

For further information on a product, technology, the most up-to-date version of a document, or your nearest sales office, please visit:
www.renesas.com/contact/

Trademarks

Renesas and the Renesas logo are trademarks of Renesas Electronics Corporation. All trademarks and registered trademarks are the property of their respective owners.