

REVISIONS					
P	LTR	DESCRIPTION	DATE	DWN	APVD
	H5	ECR-22-138429	19MAY2022	LP	DSC

AMP
WIRE RANGE

12-10 AWG
STRANDED

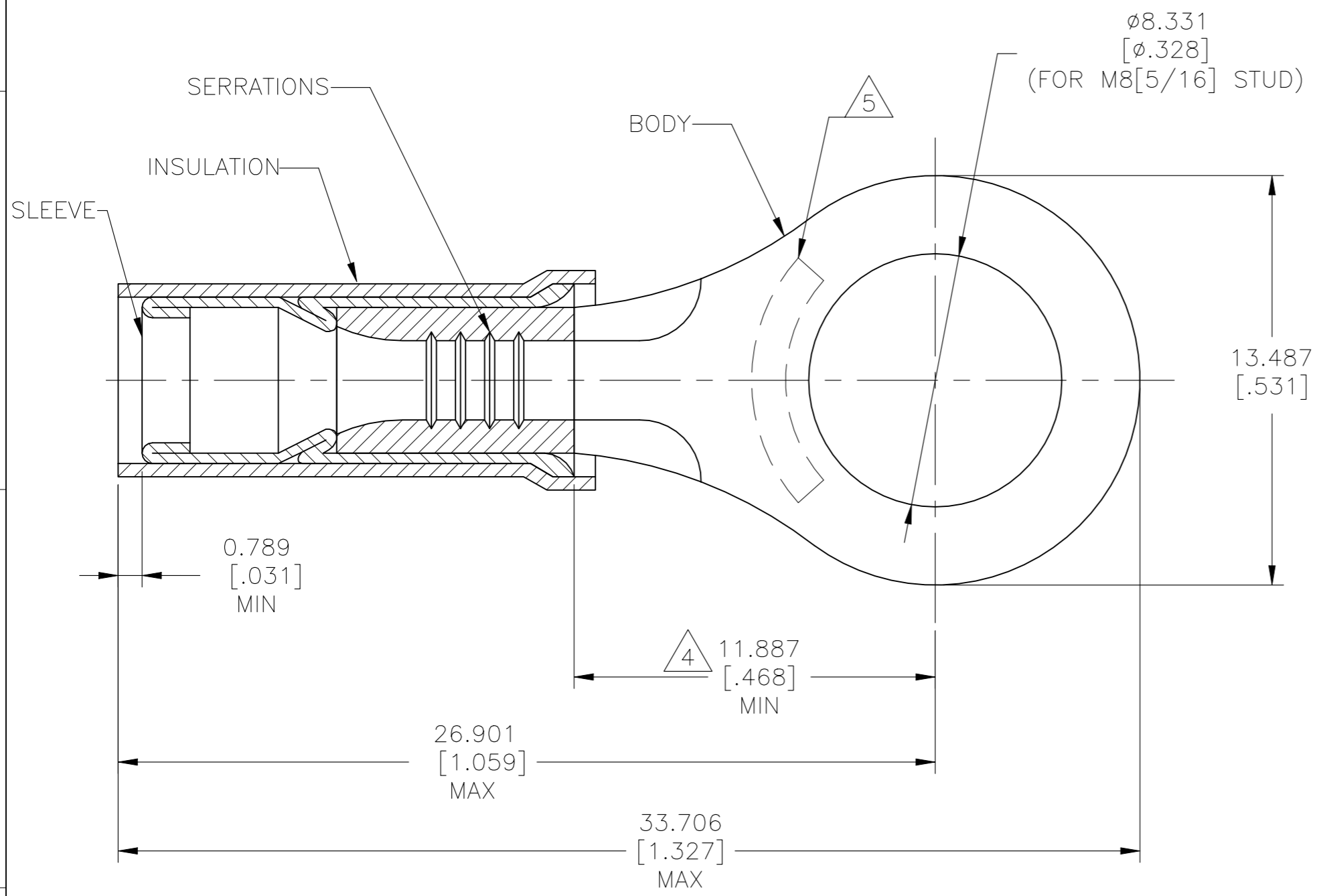

- 1 MATERIAL:
BODY & SLEEVE - COPPER PER ASTM B152
INSULATION - PTFE PER ASTM D4895
- FINISH:
BODY - NICKEL PLATE 0.00762[.00030]
AVG EXT THK PER SAE AMS-QQ-N-290
SLEEVE - NICKEL PLATE 0.001651[.000065]
AVG EXT THK PER SAE AMS-QQ-N-290
INSULATION COLOR - BLACK
- 2 FOR 2.591[.102] TO 5.436[.214]
WIRE INSULATION DIA.
- 3 BODY MATERIAL THK: 0.991±0.051[.039±.002]
- 4 DIMENSION APPLIES FROM EDGE OF
METAL WIRE BARREL TO CENTER OF
STUD HOLE
- 5 STAMP "AMP 12-10*" APPROX AS SHOWN

1000	LOOSE PIECE	50847
QTY	PACKAGE TYPE	PART NO.

AMP INCORPORATED CUSTOMER SERVICE SYSTEMS		MAX RECOMMENDED OPERATING TEMPERATURE: 288°C [550°F]	THIS DRAWING IS A CONTROLLED DOCUMENT.		DWN 13OCT2015 NAGALAKSHMI K	STE TE Connectivity							
FOR ADDITIONAL PRODUCT INFORMATION OR COPIES OF DRAWINGS AND TECHNICAL DOCUMENTS	PRODUCT INFORMATION CENTER 1-800-522-6752	VOLTAGE RATING: 300V MAX	DIMENSIONS: mm [INCHES]	TOLERANCES UNLESS OTHERWISE SPECIFIED:	CHK 13OCT2015 MERCURIO MAURIZIO				NAME TERMINAL, RING TONGUE, PIDG, STRATO-THERM, WIRE SIZE: 12-10 AWG				
FOR APPLICATION TOOLING INFORMATION	TOOLING ASSISTANCE CENTER 1-800-722-1111	CIRCULAR MIL AREA: 2.62-6.64mm²[5,180-13,100] STRANDED WIRE ONLY		0 PLC ± - 1 PLC ± - 2 PLC ± - 3 PLC ± 0.127[.005] 4 PLC ± - ANGLES ± -	APVD 13OCT2015 MERCURIO MAURIZIO	PRODUCT SPEC	APPLICATION SPEC	SIZE	CAGE CODE	DRAWING NO	RESTRICTED TO		
FOR ORDER ENTRY	1-800-526-5142		MATERIAL	FINISH	114-2162	WEIGHT	-	A3	00779	C-50847	-		
					CUSTOMER DRAWING			SCALE	NTS	SHEET	1 OF 1	REV	H5