

Technical Description SEK-SVM4x

Evaluation Kit for SGP40 and SGP41 – Indoor Air Quality Sensor for VOC and NO_x Measurements

- Sensor module equipped with SGP41 and SHT40
- On-board microcontroller for signal processing
- I²C and UART interface with digital output signals
- USB-UART cable, jumper wire cable set
- Power supply 3.0–5.5 V
- Plug-and-play for fast evaluation and prototyping



Table of Contents

| | |
|--|---|
| 1 General Description..... | 3 |
| 2 Specifications | 4 |
| 3 Sensor Output Signal Description | 7 |

1 General Description

Specifications can be found in the corresponding datasheets of both components SGP41 and SHT40. The SVM41 as part of the evaluation kit SEK-SVM4x serves as reference design for integrating SGP41, SHT40, and Sensirion's Gas Index Algorithm to obtain the VOC and NO_x Index signals as processed by the on-board microcontroller. It supports all features of both components and automatically takes care of humidity compensation of the SGP41 raw signal as well as of temperature offset compensation of the SHT40 sensor. **Figure 1** visualizes how the signal processing is performed on the SVM41.

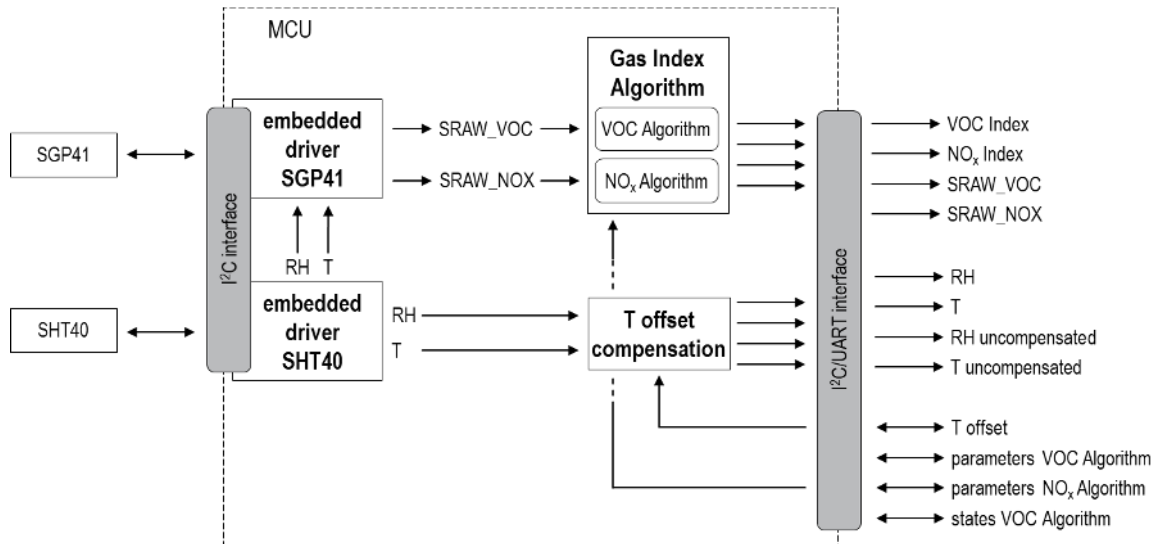

Figure 1 Schematic of the signal processing and interface on SVM41.

2 Specifications

2.1 Electrical Specifications

Table 1 lists electrical specifications of the SVM41. The SVM41 supports both I²C “standard-mode”¹ (see *NXP I²C-bus specification and user manual*) and UART.²

| Parameter | Symbol | Values | | | Unit | Comments |
|---|-----------------|--|------------|------|------|--|
| | | Min. | Typ. | Max. | | |
| Supply voltage ³ | V _{DD} | 3.0 | 3.3 or 5.0 | 5.5 | V | Minimal voltage must be guaranteed also for the maximum supply current specified in this table. |
| Idle current | I _{DD} | – | 2.0 | 3.0 | mA | at 3.3 V supply voltage The idle mode is activated after power-up as well as after calling either the <i>svm41_stop_measurement</i> or the <i>svm41_device_reset</i> command. |
| Average supply current while NO _x pixel conditioning is active | | | 6.5 | 7.5 | mA | at 3.3 V supply voltage The NO _x pixel conditioning is activated for 10 s after calling the <i>svm41_start_measurement</i> command. |
| Average supply current during measurement | | – | 5.0 | 7.5 | mA | at 3.3 V supply voltage |
| Communication | – | Digital 2-wire interface, I ² C or UART | | | | |

Table 1 Electrical specifications.

2.2 Timing Specifications

Timings in **Table 2** refer to the power up and reset of the device and do not reflect the usefulness of the readings.

| Parameter | Symbol | Condition | Min. | Typ. | Max. | Unit |
|----------------------------------|-------------------|---|------|---------|------|----------------------|
| Power-up time | t _{PU} | After hard reset, V _{DD} ≥ 3.0 V | – | 25 | 100 | ms |
| I ² C clock frequency | f _{I2C} | – | – | – | 100 | kHz |
| UART baud rate | f _{UART} | – | – | 115'200 | – | bits s ⁻¹ |
| Recommended read-out interval | – | – | 0.5 | 1 | 60 | s |

Table 2 Timing specifications.

¹ See *I²C Interface Description SVM41*.

² Universal Asynchronous Receiver Transmitter. See *UART Interface Description SVM41*.

³ Any supply voltage as defined by the min./max. range may be used for continuous operation of the sensor. The typical value specifies the supply voltage at which outgoing quality control is performed.

2.3 Recommended Operating and Storage Conditions

Please, refer to the *SGP41 Datasheet*. To ensure an optimal performance of the SVM41 also consider the *Handling and Assembly Instructions* for both *SGPxx Gas Sensors* and *SHTxx Humidity Sensors* as well as the corresponding *Design-in Guides*.

2.4 Absolute Minimum and Maximum Ratings

Stress levels beyond those listed in **Table 3** may cause permanent damage to the device. Exposure to minimum/maximum rating conditions for extended periods may affect sensor performance and reliability of the device.

| Parameter | Rating |
|---|----------------------------|
| Supply voltage V_{DD} | -0.3 to +5.5 V |
| Short-term storage temperature range ⁴ | -40 to +70 °C |
| Operating temperature range | -20 to +55 °C |
| Short-term storage humidity range ⁴ | 0 to 80 % (non-condensing) |
| Operating humidity range | 0 to 90 % (non-condensing) |

Table 3 Absolute minimum and maximum ratings.

2.5 Hardware Interface Specifications

| Pin | Name | Comments |
|-----|------|--|
| 1 | VDD | Supply voltage |
| 2 | GND | Ground |
| 3 | RX | UART: receiving pin for communication |
| | SDA | I ² C: serial data, bidirectional |
| 4 | TX | UART: transmitting pin for communication |
| | SCL | I ² C: Serial clock, bidirectional |
| 5 | SEL | Interface select: <ul style="list-style-type: none"> • Leave floating or pull to VDD to select UART • Pull to GND to select I²C |
| 6 | NC | Do not connect |

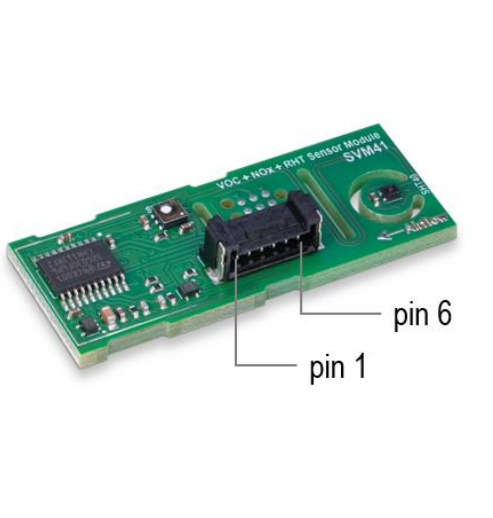

Table 4 Pin assignment of the Molex connector. Pin colors match with assignment of the jumper wire cables, which is delivered together with the SEK-SVM4x.

The SVM41 sensor module is equipped with a serial communication interface. The interface connector Molex 5055670671 is located at the side of the sensor adjacent. The UART-USB cable and the jumper wire cable delivered in the SEK-SVM4x are equipped with the corresponding female plug, *i.e.*, Molex 5055650601. In **Table 4** a description of the pin layout is given. The SVM41 offers both a UART and an I²C interface. I²C was originally designed to connect two chips on a PCB. When the sensor is connected to the main PCB *via* a cable, particular attention must be paid to electromagnetic interference and crosstalk. Use as short as possible (≤ 10 cm) and/or well shielded connection cables such as the jumper wire cable part of the SEK-SVM4x.

⁴ Short-term storage refers to temporary conditions during, *e.g.*, transport.

Alternatively, it is recommended to use the UART interface instead, which is more robust against electromagnetic interference, especially with long connection cables.

A typical I²C application circuit is shown in **Figure 2**. Both SCL and SDA lines are open drain I/Os. They must be connected to external pull-up resistors (e.g., $R_p = 10\text{ k}\Omega$). Important notice: to correctly select I²C as interface, the interface select pin (SEL) must be pulled to GND before or at the same time the sensor is powered up.

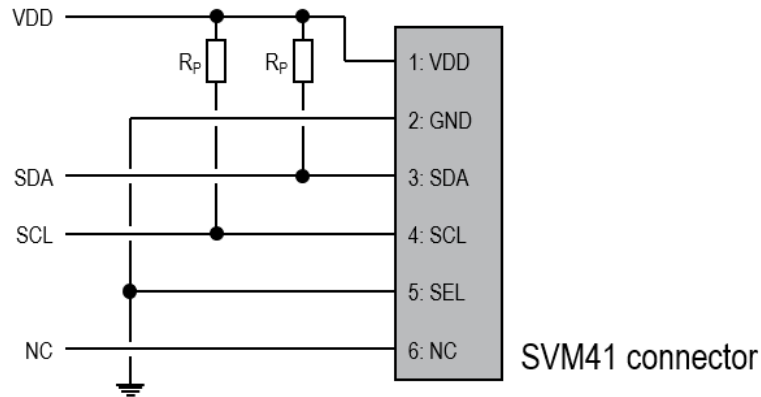

Figure 2 Typical I²C application circuit to connect the SVM41 sensor module.

A typical UART application circuit is shown in **Figure 3**.

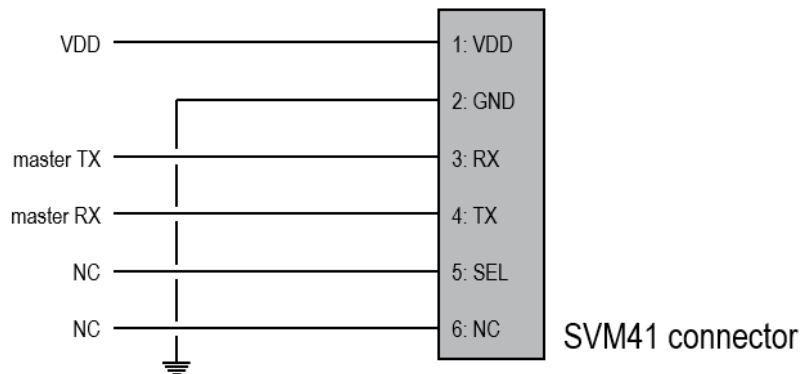

Figure 3 Typical UART application circuit to connect the SVM41 sensor module.

3 Sensor Output Signal Description

3.1 Start-up Behavior

The sensor starts powering-up after reaching the power-up threshold voltage of 3.0 V and enters idle mode after max. 100 ms. In this state, the SVM41 is ready to receive commands by the master.

3.2 Performing a Measurement

To perform a measurement, the measure mode of SVM41 has to be activated from idle mode by calling the *svm41_start_measurement* command. The measure mode remains active until either sending the *svm41_stop_measurement*, the *svm41_device_reset* command or until a hard reset is executed. During measure mode, the SVM41 performs a measurement every second irrespective of the sampling interval applied by the master to get the resulting data. Once in measure mode and after waiting for the specified time, either *svm41_get_signals* (**Figure 4**) or *svm41_get_raw_signals* (**Figure 5**) command can be called to retrieve sensor data. The master will always send back the latest result of the measurement. During the first 45 s after sending the *svm41_start_measurement* command, both the VOC and NO_x Index will be 0. Thereafter, both indices will show values ranging from 1 to 500.

The *svm41_get_signals* command provides VOC and NO_x Index as well as T-offset compensated relative humidity and temperature (**Figure 4**) while the *svm41_get_raw_signals* outputs SGP41 raw signals SRAW_VOC and SRAW_NOX as well as uncompensated relative humidity and temperature (**Figure 5**). When calling the *svm41_start_measurement* command, a conditioning of the NO_x pixel is performed for 10 s. During this period, the raw signal SRAW_NOX is 0. Thereafter, it will show values >0.

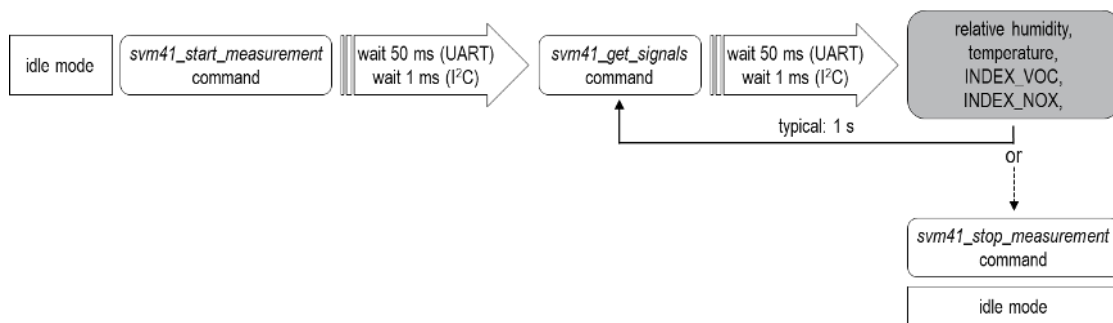

Figure 4 Process flow for performing a standard measurement with the SVM41 to receive relative humidity, temperature, VOC Index and NO_x Index.

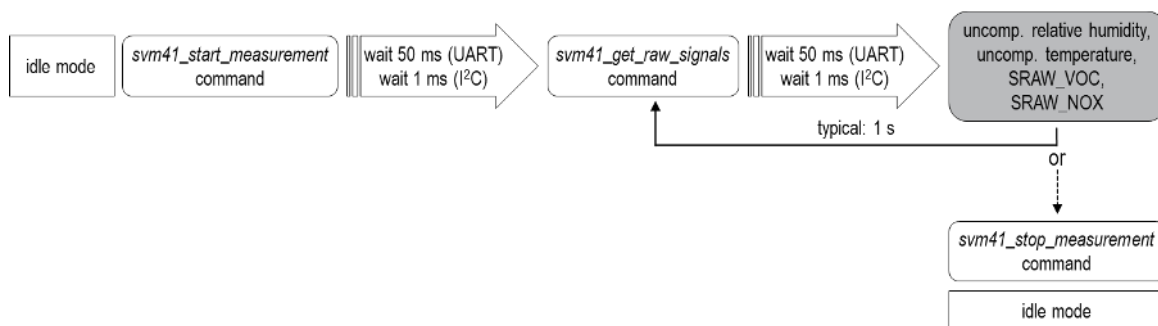

Figure 5 Process flow for performing a measurement including raw signals with the SVM41 to receive uncompensated relative humidity, uncompensated temperature, SGP41 raw VOC signal (SRAW_VOC) and SGP41 raw NO_x signal (SRAW_NOX).

3.3 Using the Temperature Offset for Compensating RHT Measurements

The SVM41 provides the possibility to compensate relative humidity and temperature signals of the SHT40 by setting a temperature offset which can be caused by self-heating of the PCB and/or other environmental influences (such as design-ins). Current temperature offset can be read out by sending the *svm41_get_temperature_offset* command at any time during idle or measure mode (**Figure 6** top). To set the offset value, use the *svm41_set_temperature_offset* command. This command can only be sent while the SVM41 is in idle mode (**Figure 6** bottom). After waiting for the specified time, the master may send the *svm41_start_measurement* command to initialize the measure mode. All RHT signals subsequently received via *svm41_get_signals* are automatically compensated. The temperature offset is not stored permanently on the SVM41. Hence, after startup and reset, the parameter must be set again if still needed. To store the parameter permanently the *svm41_store_input_parameters* command must be used (see section 3.5 Storing Input Parameters to Non-Volatile Memory).

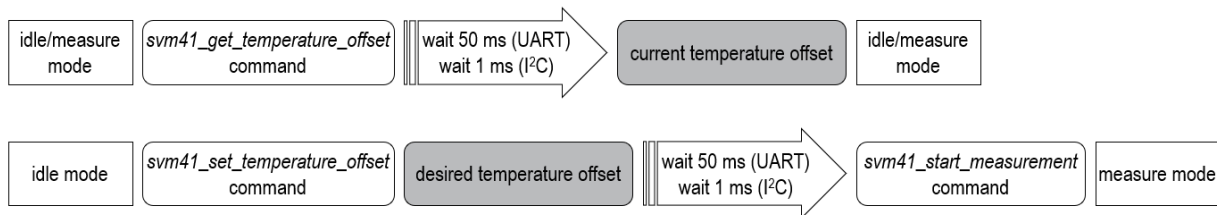

Figure 6 Implementation of the temperature offset correction for RHT signals on the SVM41.

3.4 Using the Tunability Feature of the Gas Index Algorithm

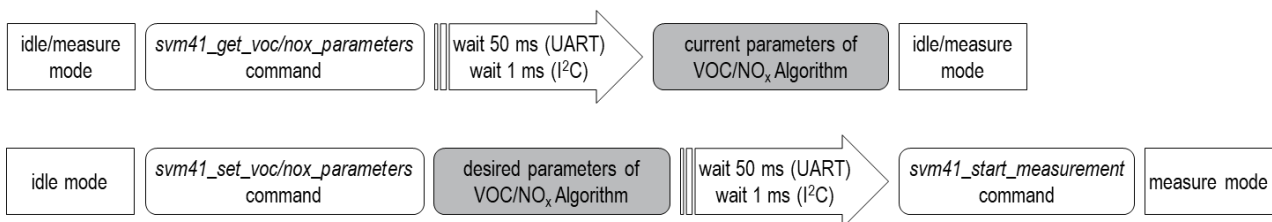

Figure 7 Implementation of the tunability feature for the Gas Index Algorithm on SVM41. The parameters are read out and/or set via separate commands for each algorithm, *i.e.*, VOC and NO_x Algorithm.

The SVM41 interface provides the possibility to tune the VOC and the NO_x Algorithm individually by a set of six different parameters. Current parameters (as listed in **Table 5**) can be read out during both idle and measure mode by sending the *svm41_get_voc_parameters* and/or *svm41_get_nox_parameters* command (**Figure 7** top). After the specified waiting time, the SVM41 replies with the payload which represents the currently set six available tuning parameters (**Table 5**). The same parameters can be set when the master calls the *svm41_set_voc_parameters* and/or *svm41_set_nox_parameters* command (**Figure 7** bottom). Note: learning time gain hours and initial standard deviation have no impact on the tuning of the NO_x Algorithm; however, they must be specified (see **Table 5**). All set parameters are not stored permanently on the SVM41. Hence, after startup and reset parameters must be set again if still needed. To store the parameters permanently the *svm41_store_input_parameters* command must be used (see section 3.5 Storing Input Parameters to Non-Volatile Memory).

| Parameter | Name in driver | Meaning | Default VOC | Default NO _x | Min. | Max. | Unit |
|---|--|--|-------------|-------------------------|------|-------|------|
| Average Index, \bar{x}_{Index} | <i>voc_index_offset</i> , <i>nox_index_offset</i> | Gas Index value to which the average conditions shall be mapped. | 100 | 1 | 1 | 250 | – |
| Learning time offset hours, t_{offset} | <i>learning_time_offset_hours</i> | Duration as rolling window used by the Gas Index Algorithm to estimate its offset from history. Data longer than approx. twice the learning time will be forgotten. | 12 | 12 | 1 | 1'000 | h |
| Learning time gain hours, t_{gain} | <i>learning_time_gain_hours</i> | Duration as rolling window used by the Gas Index Algorithm to estimate its gain from history. Data longer than approx. twice the learning time will be forgotten. | 12 | 12 ⁵ | 1 | 1'000 | h |
| Maximum gating duration, t_{gating} | <i>gating_max_duration_minutes</i> | During this period, the estimator of the Gas Index Algorithm states is frozen when the Gas Index is very high. If the Gas Index remains high, the Gas Index Algorithm will start to adapt its states after this period to this new situation. 0 disables this feature. | 180 | 720 | 0 | 3000 | min |
| Initial standard deviation, σ_{initial} | <i>std_initial</i> | Initial standard deviation is used during start-up of the sensor and Gas Index Algorithm. During this period, a lower value boosts Gas Index events while a higher value decreases Gas Index events which will have an impact on device-to-device variation. | 50 | 50 ⁵ | 10 | 5000 | – |
| Gain factor, f_{gain} | <i>gain_factor</i> | Factor to either amplify or attenuate the entire Gas Index signal. | 230 | 230 | 1 | 1'000 | – |

Table 5 List of tunable parameters of the Gas Index Algorithm.

3.5 Storing Input Parameters to Non-Volatile Memory

The temperature offset used for compensating the RHT signals via the *svm41_set_temperature_offset* command as well as the parameters used for tuning the Gas Index Algorithm via the *svm41_set_voc_parameters* and *svm41_set_nox_parameters* commands can be permanently stored to the non-volatile memory of SVM41 by calling the *svm41_store_input_parameters* command and a subsequent waiting for max. 500 ms (**Figure 8**). For this, at least one of the set commands must be called before. The *svm41_store_input_parameters* command can be called at any time and during both idle and measure mode. After any hard or soft reset the corresponding algorithms will use the stored parameters. To set the storage back to factory settings, the master must overwrite all parameters applying the same set of commands while using the default values (see interface descriptions).

⁵ Parameter just for consistency purposes. Always set this parameter to the default value.

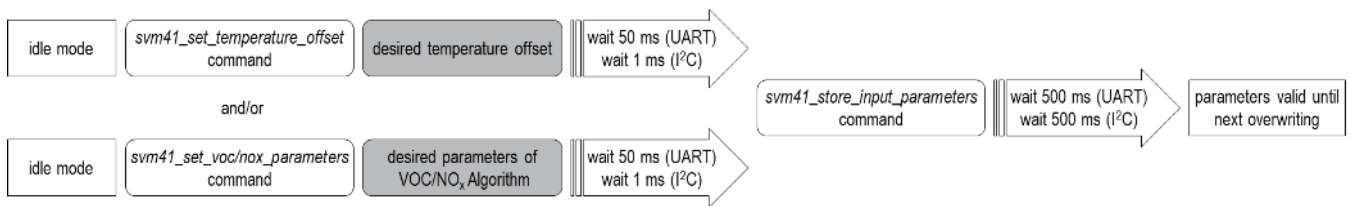

Figure 8 How to store the temperature offset used for compensating RHT signals and parameters of the Gas Index Algorithm to the non-volatile memory of SVM41.

3.6 Using the Memory Feature of the VOC Algorithm

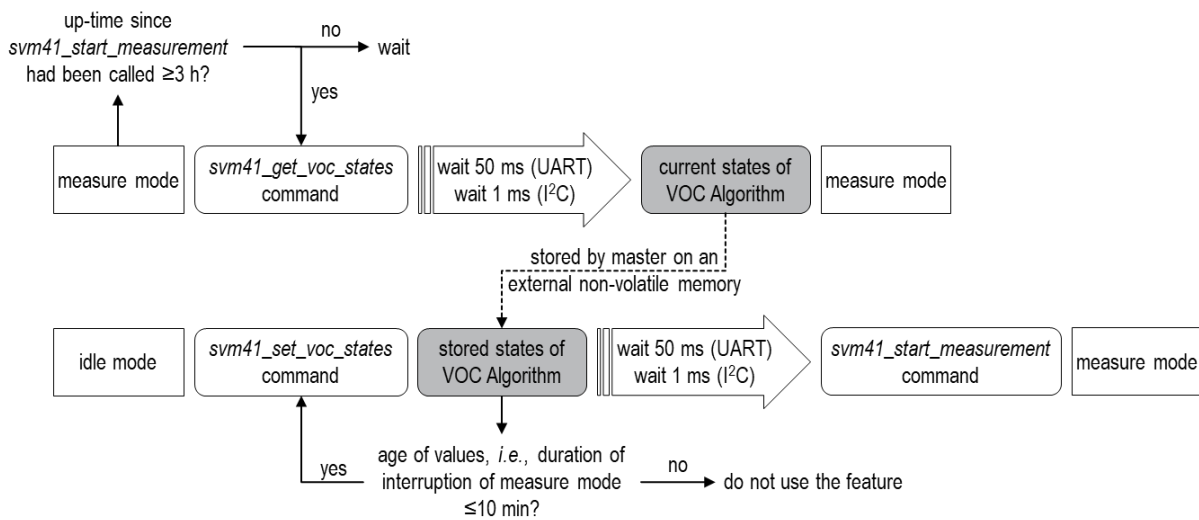

Figure 9 Implementation of the memory feature for the VOC Algorithm on SVM41.

The SVM41 allows the master to store the current states of the VOC Algorithm to resume operation with the same states after an interruption (e.g., after a blackout). This will skip the initial learning phase of the VOC Algorithm (i.e., the first 90 min after sending the *svm41_start_measurement* command while staying in measure mode). To use this feature, the master needs to send the *svm41_get_voc_states* command not until the measure mode has been run for at least 3 h (**Figure 9**). After the specified waiting time, the SVM41 replies with the payload, which contains the states of the VOC Algorithm. These values must be stored by the master on an external non-volatile memory together with an absolute timestamp. Once the SVM41 is powered-up and in idle mode again, the master may send the *svm41_set_voc_states* command together with the stored states back to the slave. This should be executed only when the stored parameters are not older than 10 minutes. After the specified waiting time, the master may call the *svm41_start_measurement* command to enter the measure mode again. The VOC Algorithm will now use the states sent by the slave to provide the VOC Index.

Note: The states sent via the *svm41_set_voc_states* command are only considered for the very beginning after restarting the measure mode. After that, the estimator will continuously adapt the states on the rolling window as given by the learning times (see section 3.4 Using the Tunability Feature of the Gas Index Algorithm). This feature is only available for the VOC Algorithm.

3.7 Resetting the Device

The SVM41 can be reset by either hard reset or by sending the *svm41_reset_device* command. In the latter case, the slave will first reply and after max. 100 ms the SVM41 restarts and enters the idle mode. All previously stored parameters (sent by the *svm41_set_temperature_offset*, *svm41_set_voc_parameters*, *svm41_set_nox_parameters*, and *svm41_set_voc_states* commands) will be erased upon resetting the device. The temperature offset and the Gas Index Algorithm parameters can be stored to the non-volatile memory of SVM41 by calling the *svm41_store_input_parameters* command.

Revision History

| Date | Version | Page(s) | Changes |
|---------------|---------|---------|---|
| October 2021 | 1.0 | All | Initial release |
| December 2021 | 1.1 | All | Editorial amendments |
| | | 4 | Average supply current during NO _x pixel conditioning added to Table 1 |
| | | 9 | Default value for maximum gating duration for NO _x Algorithm in Table 5 changed |
| January 2022 | 1.2 | 9 | Added column "Name in driver" to Table 5 |

Headquarters and Subsidiaries

Sensirion AG

Laubisruestr. 50
CH-8712 Staefa ZH
Switzerland

phone: +41 44 306 40 00
fax: +41 44 306 40 30
info@sensirion.com
www.sensirion.com

Sensirion Taiwan Co. Ltd

phone: +886 3 5506701
info@sensirion.com
www.sensirion.com

Sensirion Inc., USA

phone: +1 312 690 5858
info-us@sensirion.com
www.sensirion.com

Sensirion Japan Co. Ltd.

phone: +81 3 3444 4940
info-jp@sensirion.com
www.sensirion.com/jp

Sensirion Korea Co. Ltd.

phone: +82 31 337 7700~3
info-kr@sensirion.com
www.sensirion.com/kr

Sensirion China Co. Ltd.

phone: +86 755 8252 1501
info-cn@sensirion.com
www.sensirion.com/cn

To find your local representative, please visit www.sensirion.com/distributors