

---

## Designated client product

This product will be discontinued its production in the near term.  
And it is provided for customers currently in use only, with a time limit.  
It can not be available for your new project. Please select other new or existing products.

For more information, please contact our sales office in your region.

New Japan Radio Co.,Ltd.

[www.njr.com](http://www.njr.com)

## 8-BIT HIGH SPEED MULTIPLYING D / A CONVERTER

### ■ GENERAL DESCRIPTION

NJMDAC-08C series are 8-bit monolithic multiplying digital to analog converters with very high speed performance. Open collector output provides dual complementary current outputs increasing versatility in application.

Adjustable threshold logic input voltage through  $V_{LC}$  pin, can be connected to various type of digital IC products.

### ■ FEATURES

- Resolution (8bit)
- Setting Time (85ns)
- Linearity Error ( $\pm 0.1\%$ FS MAX (NJM DAC-08H))
- Full scale Current Temperature Drift (50ppm / °C MAX (NJM DAC-08H / E))
- Wide Operating Voltage ( $\pm 5V$  to  $\pm 18V$ )
- Wide Output Voltage Range ( $-10V$  to  $+18V$ )
- Wide Range Adjustable Threshold Logic Input ( $-10V$  to  $+13.5V$  ( $V^+ / V^- = \pm 15V$ ))
- Multiplying operations can be performed
- Package Outline DIP16, DMP16
- Bipolar Technology

### ■ PACKAGE OUTLINE

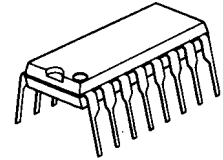

NJMDAC-08DC

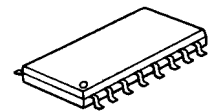

NJMDAC-08MC

### ■ PIN CONFIGURATION

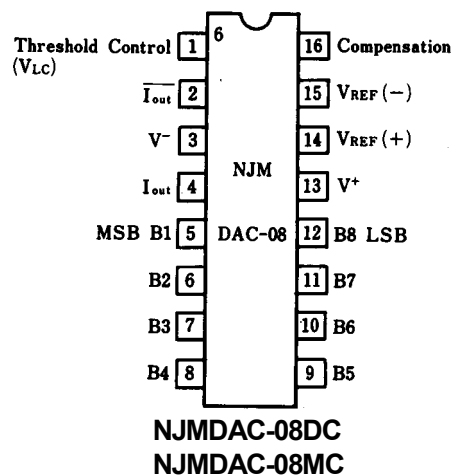

### ■ BLOCK DIAGRAM

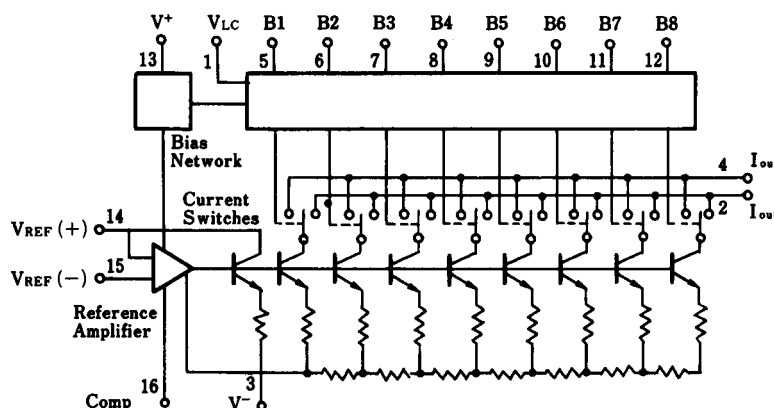

# NJMDAC-08C

## ■ ABSOLUTE MAXIMUM RATINGS

( $T_a=25^{\circ}\text{C}$ )

PARAMETER	SYMBOL	RATINGS	UNIT
Supply Voltage	$V^+ - V^-$	36	V
Logic Input Voltage Range	$V_I$	$V^-$ to $V^+ + 36$	V
Threshold Control Input Voltage	$V_{LC}$	$V^-$ to $V^+$	V
Analog Current Outputs	$I_o$	4.2	mA
Reference Input Voltage Range	$V_{REF}$	$V^-$ to $V^+$	V
Reference Input Differential Voltage	$V_{REF(+)} - V_{REF(-)}$	$\pm 18$	V
Reference Input Current	$I_{REF}$	5.0	mA
Power Dissipation	$P_D$	(DIP16) 500 (DMP16) 300	mW mW
Operating Temperature Range	$T_{opr}$	-20 to +75	$^{\circ}\text{C}$
Storage Temperature Range	$T_{stg}$	-40 to +125	$^{\circ}\text{C}$

## ■ ELECTRICAL CHARACTERISTICS

(V<sup>+</sup>=±15V, I<sub>REF</sub>=2.0mA, T<sub>a</sub>=25°C)

PARAMETER	SYMBOL	TEST CONDITION	MIN.	TYP.	MAX.	UNIT
Resolution			8	8	8	Bit
Monotonicity			8	8	8	Bit
Nonlinearity	NL				±0.39	%FS
*1 Settling Time	t <sub>s</sub>	T <sub>O</sub> ±1 / 2LSB, all bits switched ON or OFF		85	150	ns
*1 Propagation Delay	t <sub>PLH</sub> t <sub>PHL</sub>	All bits switched		35	60	ns
*1 Full Scale Temperature Coefficient	TCI <sub>FS</sub>			±10	±80	ppm / °C
Output voltage Compliance	V <sub>OC</sub>	ΔI <sub>FS</sub> <1 / 2LSB R <sub>OUT</sub> >20MΩtyp.	-10		+18	V
Full Scale Current	I <sub>FS4</sub>	V <sub>REF</sub> =10.000V R <sub>14</sub> , R <sub>15</sub> =5.000kΩ	1.94	1.99	2.04	mA
Full Scale Symmetry	I <sub>FSS</sub>	I <sub>FS4</sub> - I <sub>FS2</sub>		±2.0	±16.0	μA
Zero Scale Current	I <sub>ZS</sub>			0.2	4.0	μA
Output Current Range	I <sub>OR1</sub>	V <sub>REF</sub> =15V, V=10V	2.1			mA
	I <sub>OR2</sub>	V <sub>REF</sub> =25V, V=12V, R <sub>14</sub> , R <sub>15</sub> =15.000kΩ	4.2			mA
Logic Input Level "0"	V <sub>IL</sub>	V <sub>LC</sub> =0V			0.8	V
Logic Input Level "1"	V <sub>IH</sub>	V <sub>LC</sub> =0V	2.0			V
Logic Input Current "0"	I <sub>IL</sub>	V <sub>LC</sub> =0V, V <sub>IN</sub> = -10V to +0.8V		-2.0	-10	μA
Logic Input Current "1"	I <sub>IH</sub>	V <sub>LC</sub> =0V, V <sub>IN</sub> =2V to 18V		0.002	10	μA
Logic Input Swing	V <sub>IS</sub>		-10		+18	V
Logic Threshold Range	V <sub>TH2</sub>		-10		+13.5	V
Reference Bias Current	I <sub>IS</sub>			-1.0	-3.0	μA
*1 Reference Input Slew Rate	dl / dt		4.0	8.0		mA / μs
*2 Power Supply Sensitivity	PSSI <sub>FS</sub>	V=4.5V to 18V, I <sub>REF</sub> =1.0mA		±0.0003	±0.01	% / %
	PSSI <sub>FS</sub>	V= -4.5V to 18V, I <sub>REF</sub> =1.0mA		±0.002	±0.01	
*3 Operating Current	I <sup>+</sup>	V <sup>±</sup> =±5V, I <sub>REF</sub> =1.0mA		2.3	3.8	mA
	I <sup>-</sup>	V <sup>±</sup> =±5V, I <sub>REF</sub> =1.0mA		-4.3	-5.8	
	I <sup>+</sup>	V <sup>+</sup> =5V, V <sup>-</sup> = -15V		2.4	3.8	
	I <sup>-</sup>	V <sup>+</sup> =5V, V <sup>-</sup> = -15V		-6.4	-7.8	
	I <sup>+</sup>			2.5	3.8	
	I <sup>-</sup>			-6.5	-7.8	

\*1 Guaranteed by design

\* 2 Calculation formula 
$$PSSI_{FS} = \left( \frac{|\Delta I_{FS}|}{I_{FS}} \times 100 \right) \div \left( \frac{18 - 4.5}{15} \right) \times 100$$

\* 3 Calculation formula 
$$P_D = I^+ \times (V^+ - V^-) + 2I_{REF} \times |V^-|$$

# NJMDAC-08C

## ■ TYPICAL CHARACTERISTICS

Full Scale Current vs. Reference Input Current

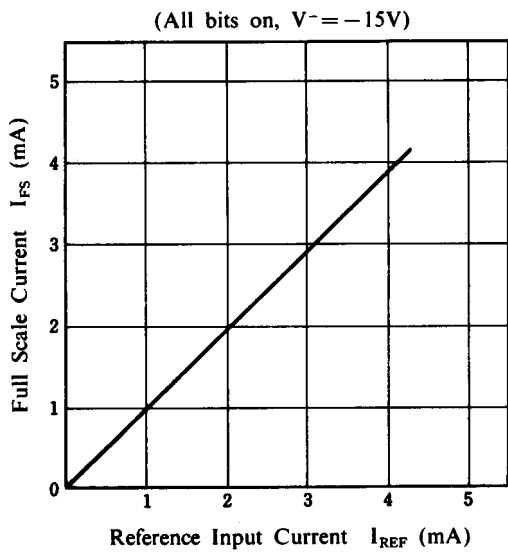

Reference Input Frequency Respons

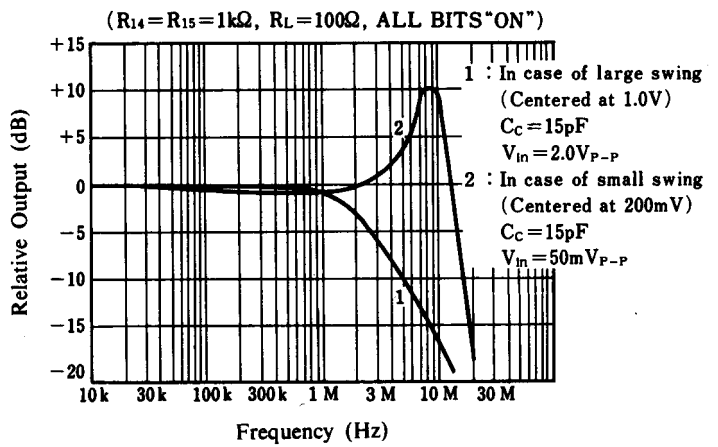

Output Current vs. Output voltage

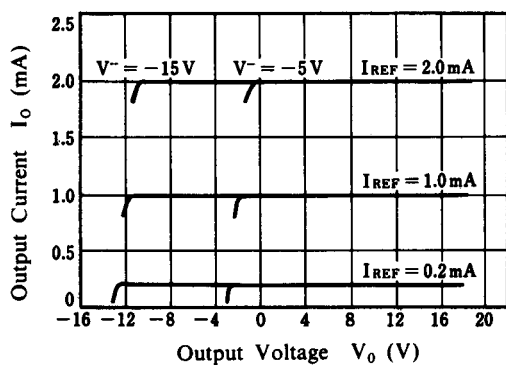

Propagation Delay Time vs. Full Scale Current

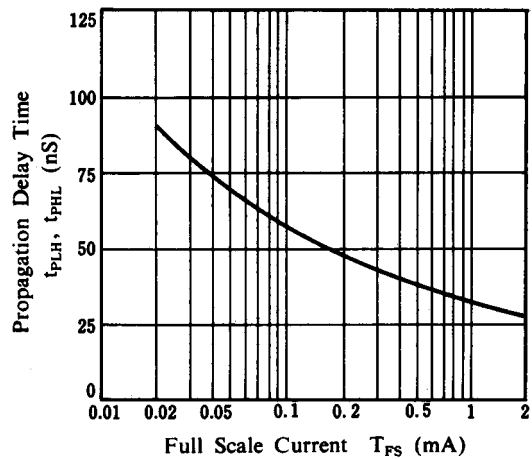

Operating Current vs. Operating Voltage

(ALL BITS "HIGH", OR "LOW")

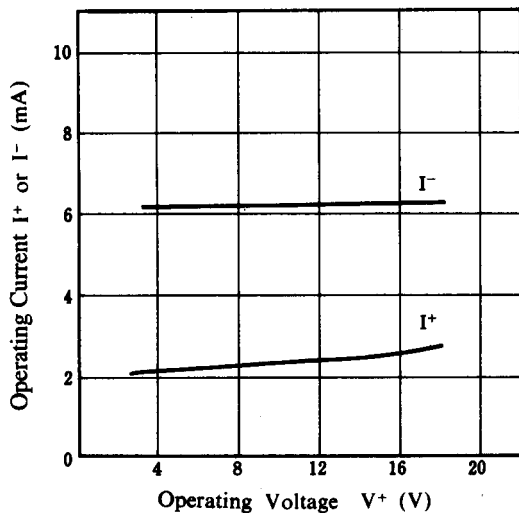

Operating Current vs. Operating Voltage

(BITS MAY BE "HIGH" OR "LOW")

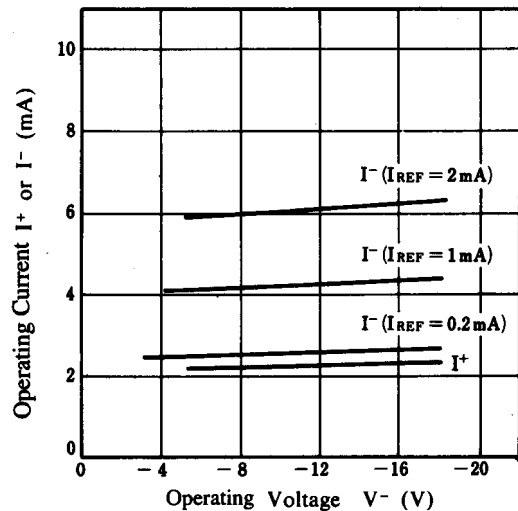

## ■ TYPICAL CHARACTERISTICS

Operating Current vs. Ambient Temperature

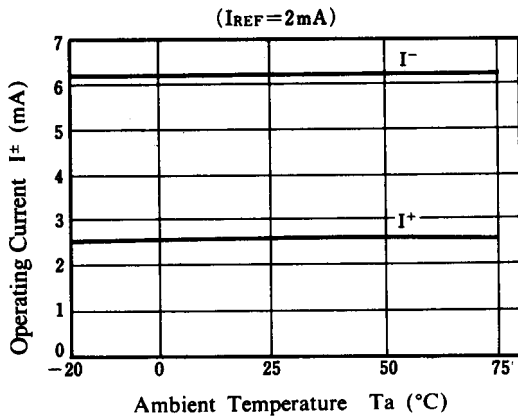

Full Scale Current vs. Ambient Temperature

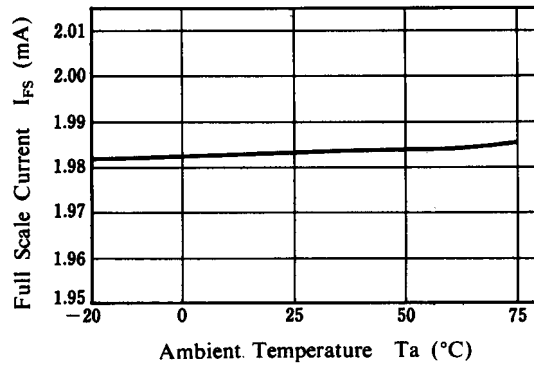

## ■ TYPICAL APPLICATION

### ① Connecting Reference Voltage

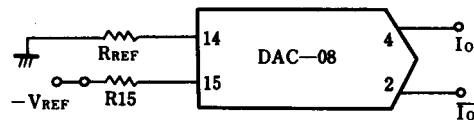
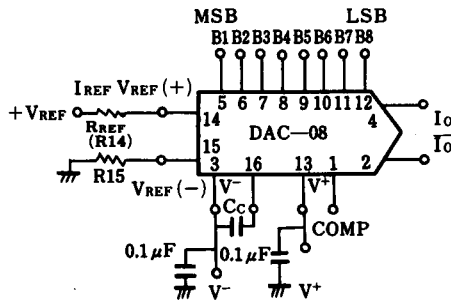

#### ① Positive Reference Voltage

Minimum Compensation Capacitance  
 $C_C = R_{REF}(\text{k}\Omega) \times 15(\text{pF})$

#### ② Negative Reference Voltage

Recommended  $C_C$  Value  
 (When  $V_{REF}$  is DC)

### ② Connecting Output Circuit

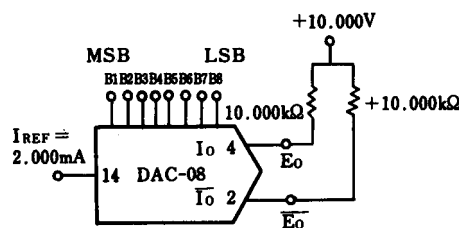

	B1	B2	B3	B4	B5	B6	B7	B8	$E_o$	$\bar{E}_o$
POS FULL RANGE	1	1	1	1	1	1	1	1	-9.920	+10.000
POS FULL RANGE - LSB	1	1	1	1	1	1	1	0	-9.840	+9.920
ZERO SCALE ÷ LSB	1	0	0	0	0	0	0	1	-0.050	+0.160
ZERO SCALE	1	0	0	0	0	0	0	0	0.000	+0.050
ZERO SCALE - LSB	0	1	1	1	1	1	1	1	+0.080	0.000
NEG FULL SCALE ÷ LSB	0	0	0	0	0	0	0	1	+9.920	-9.840
NEG FULL SCALE	0	0	0	0	0	0	0	0	+10.000	-9.920

(1) Basic Bipolar Output Operation

# NJMDAC-08C

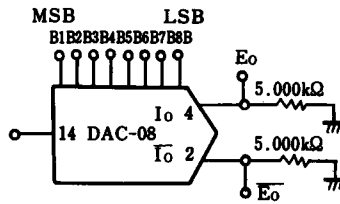

	B1	B2	B3	B4	B5	B6	B7	B8	InmA	InmA	E <sub>0</sub>	$\bar{E}_0$
FULL RANGE	1	1	1	1	1	1	1	1	1.992	0.000	-9.960	-0.000
HALF SCALE ÷ LSB	1	0	0	0	0	0	0	1	1.008	0.984	-5.040	-4.920
HALF SCALE	1	0	0	0	0	0	0	0	1.000	0.992	-5.000	-4.960
HALF SCALE - LSB	0	1	1	1	1	1	1	1	0.992	1.000	-4.960	-5.000
ZERO SCALE ÷ LSB	0	0	0	0	0	0	0	1	0.008	1.984	-0.040	-9.920
ZERO SCALE	0	0	0	0	0	0	0	0	0.000	1.992	-0.000	-9.950

(2) Basic Unipolar Negative Operation

### ③ Connecting Output Buffer Amp.

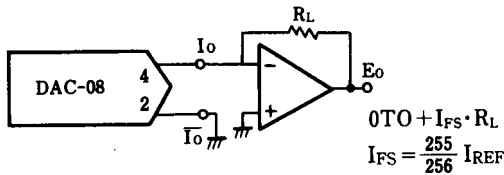

(1) Positive Low Impedance Output Operation

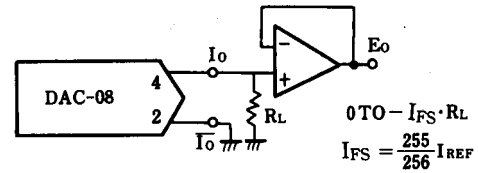

(2) Negative Low Impedance Output Operation

### ④ Connecting to various type logic IC products

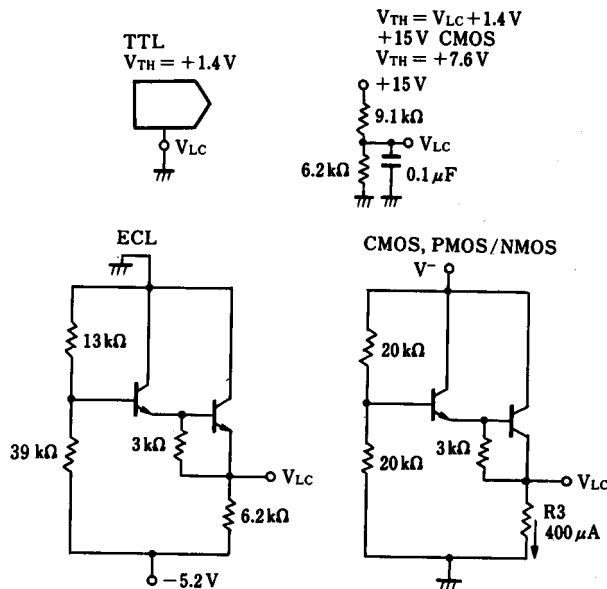

$V_{TH}$  temperature compensation is considered in the above circuit

[CAUTION]  
 The specifications on this databook are only given for information, without any guarantee as regards either mistakes or omissions. The application circuits in this databook are described only to show representative usages of the product and not intended for the guarantee or permission of any right including the industrial rights.