

NOTES:

1. RoHS COMPLIANT
2. FOR WAVESOLDERING (SOLDER BATH TEMPERATURE 260°C FOR 5 SEC. AND SOLDER PREHEAT 100°C FOR 30 SEC.)
3. METALSHELLS: STEEL; min. 315µm TIN over 40-80µm NICKEL
4. INSULATORS: HIGH TEMPERATURE PLASTIC UL 94 V-0, BLACK
5. CONTACTS: COPPER ALLOY; PLATING (SEE PART NO):
 - PLEASE ADD A for GOLD FLASH over NICKEL (PREFERRED TYPE)
 - PLEASE ADD B for 20µm HARD GOLD over min. 50µm NICKEL
 - PLEASE ADD C for 30µm HARD GOLD over min. 50µm NICKEL
 CONTACT TAILS PRETINNED
6. METAL BRACKETS: ZINC DIE CAST; 300µm COPPER/40-120µm NICKEL/120-200µm TIN
7. THREADED INSERTS: COPPER ALLOY; min. 200µm TIN over 80µm NICKEL
8. PCB-SNAPS: COPPER ALLOY; min. 200µm TIN over 80µm NICKEL
PCB-HOLE: Ø3,1±0,1; PCB THICKNESS 1,6mm
9. FIXING-PLATE: HIGH TEMPERATURE PLASTIC UL 94 V-0; BLACK
10. CAPACITANCE: 370pF±20%
11. DIELECTRIC WITHSTANDING VOLTAGE: 424 VDC
12. P.C.B. HOLE DRILLINGS ON SHEET 2
13. MAXIMUM TORQUE VALUE FOR THREAD: 6 in.LB
14. CONNECTOR IS PART MARKED: 242□17760X CONEC ABC (see note 5)

Directive 2002/95/EC RoHS compliant

THIS DRAWING MAY NOT BE COPIED OR REPRODUCED IN ANY WAY, AND MAY NOT BE PASSED ON TO A THIRD PARTY WITHOUT WRITTEN PERMISSION. OWNERSHIP AND COPYRIGHT OF CONEC GmbH

DO NOT ALTER CAD DRAWING BY HAND

				tolerance		dim. in mm
				date	name	
				drawn	14.09.12	Henneboel
				appd.	14.09.12	Fischer
				norm		
				d-old	24K1A560	
1 x b	Ä4461	14.09.2012	K.H.	CONEC ®		
a	Original					
rev.	description	date	name			

scale:	2:1 (5:1)	
material:	SEE NOTES	
title:	D-SUB FILTER FEMALE 90° 25pos. SOLDER PIN ANGLED 0.318inch with threaded insert, metal bracket, snap, fixing plate	
dwg no:	24K1A1409 (b)	DIN-A3 sh: 1/2
part no:	242□17760X (see note 5)	

P.C.B. HOLE DRILLINGS

(P.C.B. TOP SIDE)

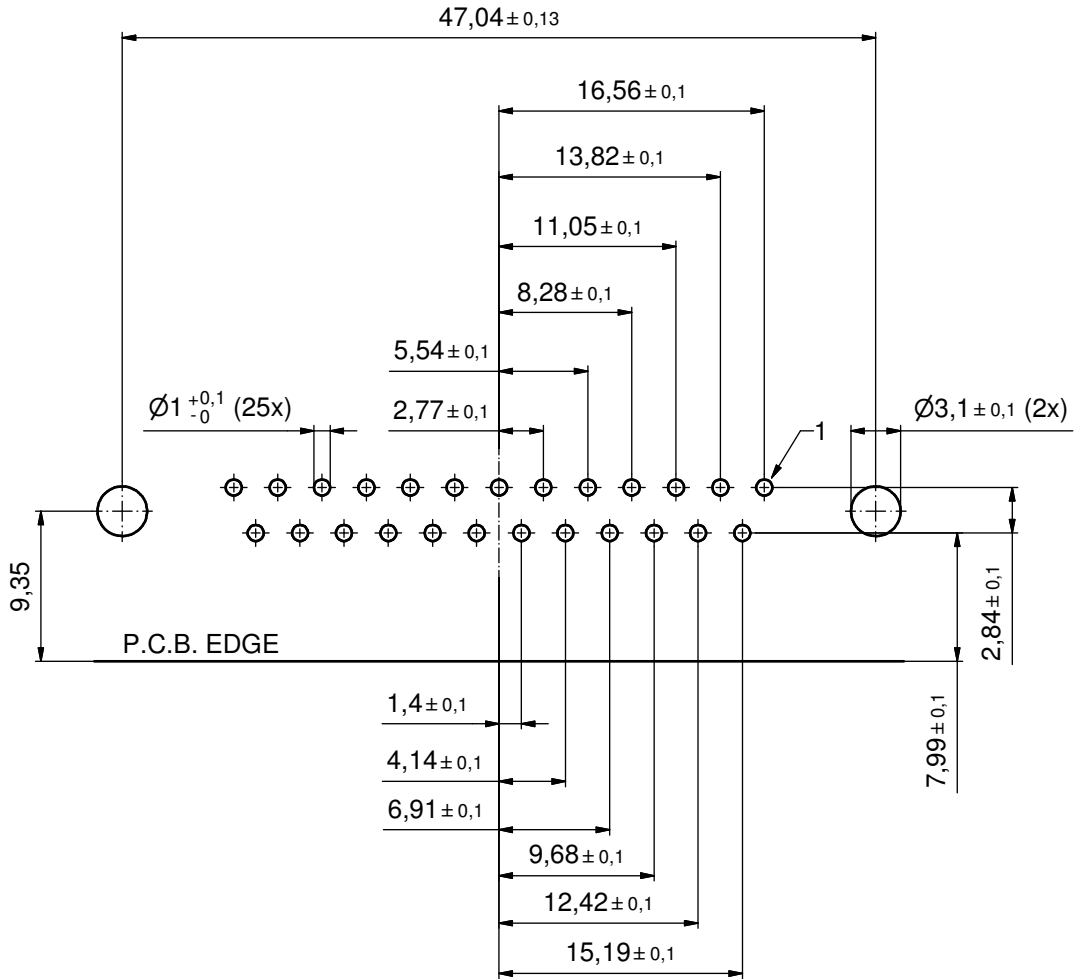

THIS DRAWING MAY NOT BE COPIED OR REPRODUCED IN ANY WAY, AND MAY NOT BE PASSED ON TO A THIRD PARTY WITHOUT WRITTEN PERMISSION. OWNERSHIP AND COPYRIGHT OF CONEC GmbH DO NOT ALTER CAD DRAWING BY HAND				tolerance		scale: 3:1	
				date	name	material: SEE SHEET 1	
				drawn	14.09.12	Henneboel	
				appd.	14.09.12	Fischer	
				norm			
				d-old			
	a	Original		CONEC [®]			title: P.C.B. HOLE DRILLINGS D-SUB FILTER FEMALE 90°, 25pos. 0.318inch with threaded insert, metal bracket, snap, fixing plate
	rev.	description	date				name
							part no: SEE SHEET 1