

LOC		DIST		REVISIONS			
P	LTR	DESCRIPTION	DATE	DNW	APVD		
H		REV PER ECO 15-005910	5-20-15	CT	DM		

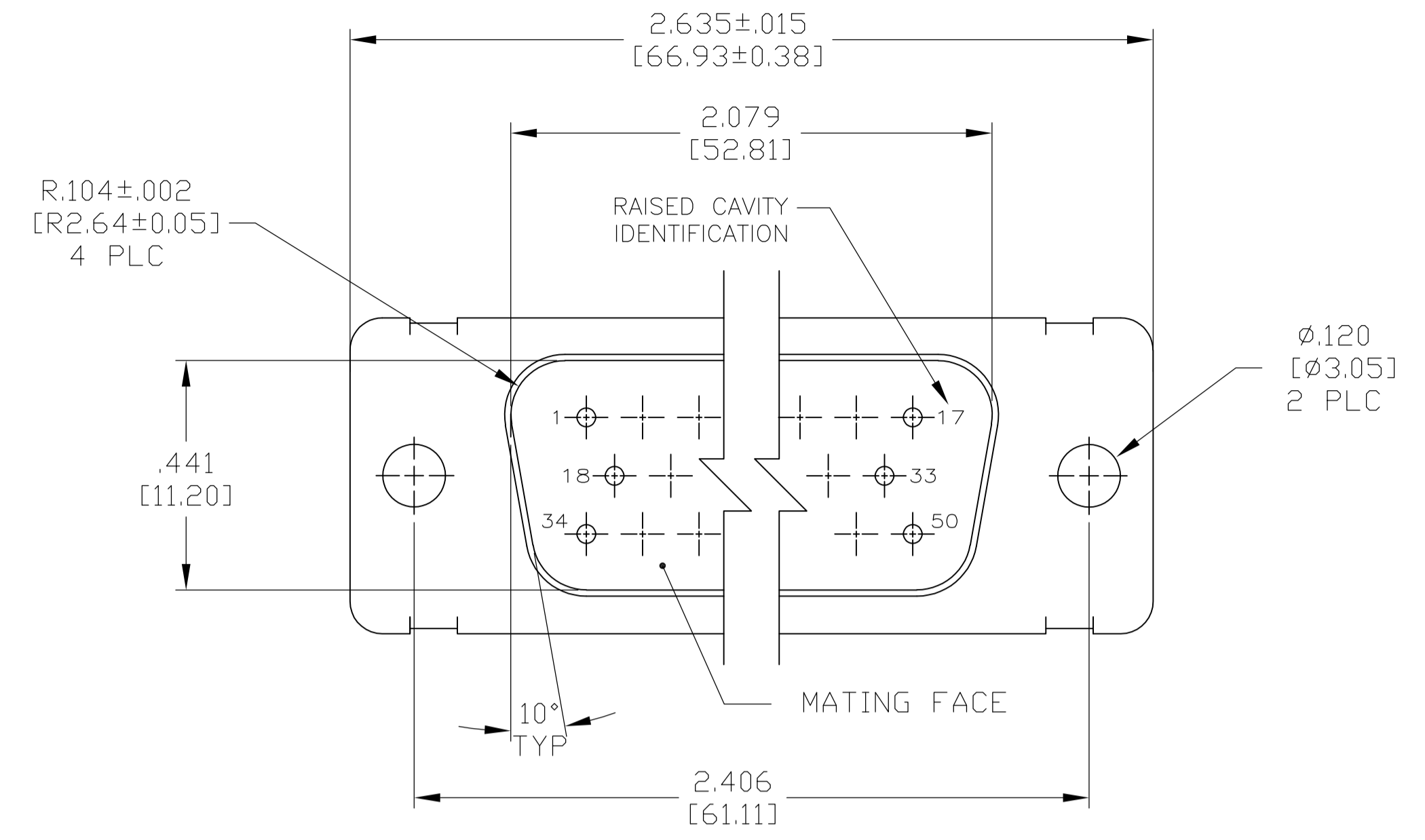

1. THIS CONNECTOR ASSEMBLY IS SUPPLIED WITH Be Cu CONTACT RETENTION CLIPS INSTALLED IN THE INSERT ASSEMBLY.
2. THIS CONNECTOR ASSEMBLY MATES WITH ANY PLUG CONNECTOR WITH THE SAME INSERT ARRANGEMENT AND DIMENSIONAL REQUIREMENTS PER MIL-C-24308.
3. MARKED WITH .047 [1.19]-.062 [1.57] HIGH CHARACTERS. FAR SIDE REFERS TO THE WIDE SIDE OF THE KEYSTONE. NEAR SIDE REFERS TO THE NARROW SIDE OF THE KEYSTONE.
4. MAXIMUM WIRE INSULATION TO BE USED WITH THIS CONNECTOR ASSEMBLY IS .054 [1.37] DIAMETER.
5. SPECIAL REQUIREMENTS PER BDEING 1A01 DOCUMENT.
6. BUILT TO ORDER, NO INVENTORY OF THIS PART NUMBER IS TO BE KEPT. SINGLE LOT DATE CODE REQUIRED.

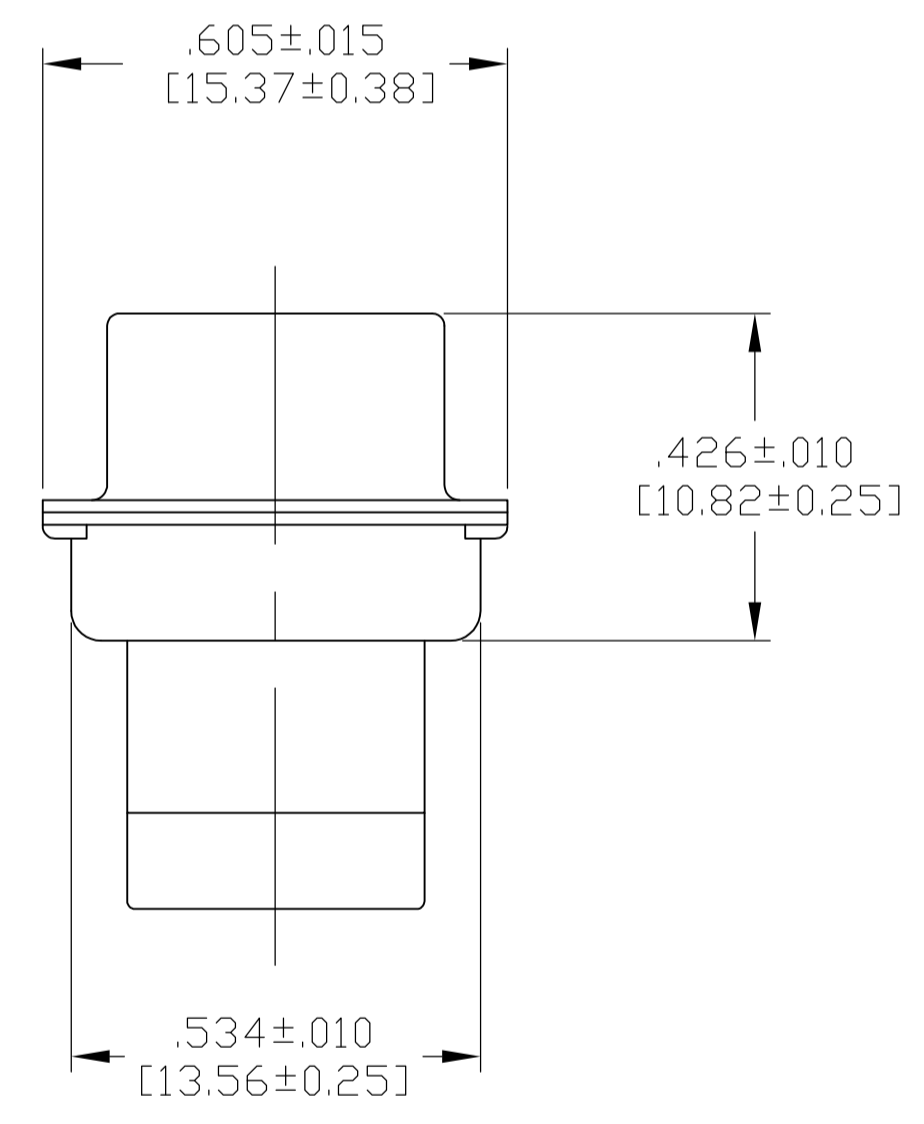
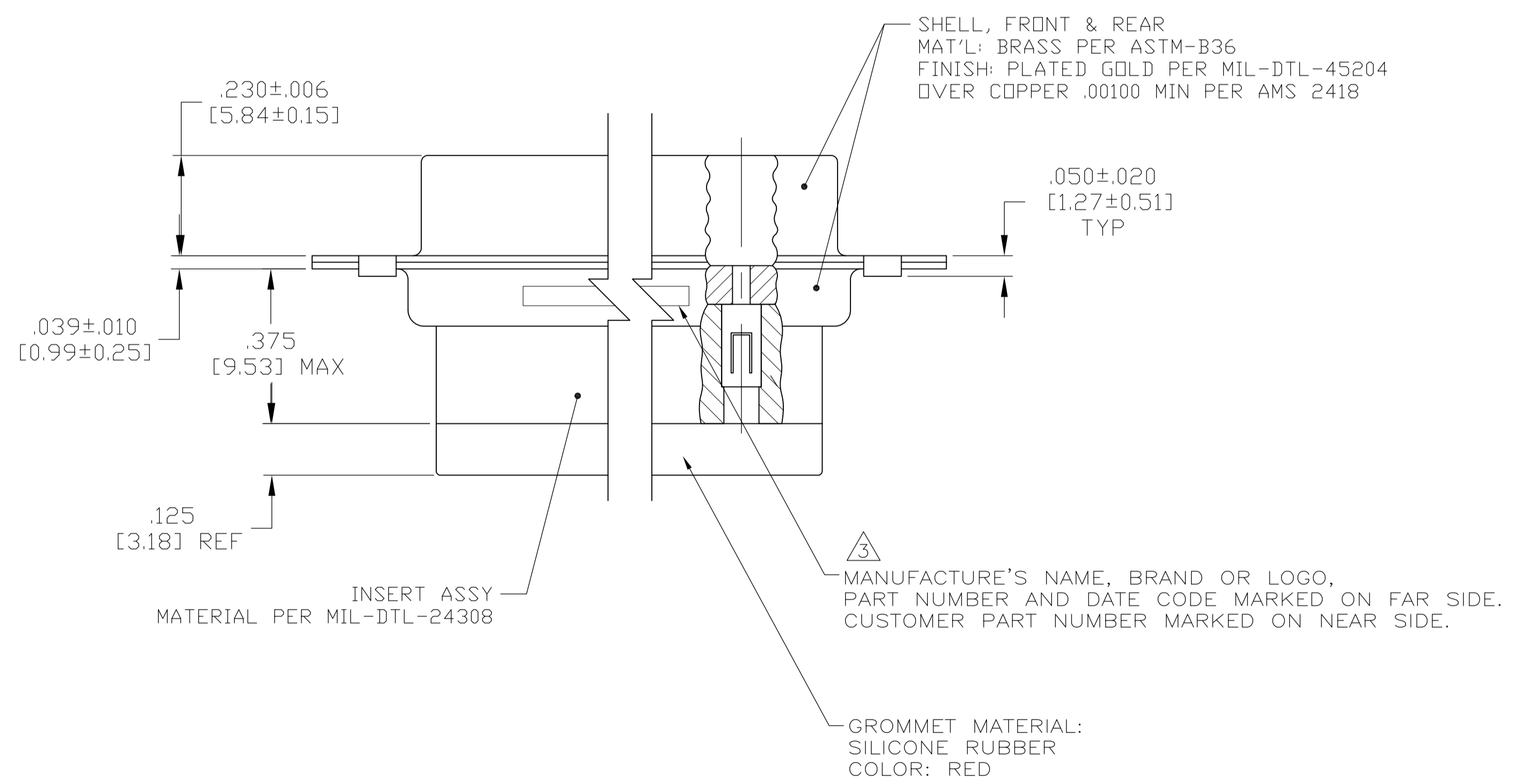

5 6	1A01-030PHW	1-211642-1
6	A70323-12013-030	211642-8
--	---	211642-4
5 6	1A01-030PHA	211642-1
REMARKS	CUSTOMER MARKING	PART NUMBER

THIS DRAWING IS A CONTROLLED DOCUMENT.

DIMENSIONS: INCHES	TOLERANCES UNLESS OTHERWISE SPECIFIED:	DIN C.C.THOMAS 4-9-09	APVD R LEASE 4-9-09
0 PLC ± -	1 PLC ± -	2 PLC ± -	3 PLC ± .005 [0.13]
4 PLC ± -	ANGLES ± -	FINISH SEE CALLOUTS	WEIGHT --

STE TE Connectivity

NAME: PLUG ASSY,AMPLIMITE.50 POSN.,SIZE 5, SERIES 109 WITH GROMMET, NON-MAGNETIC

SIZE: A1 CASE CODE: 00779 DRAWING NO: 211642

CUSTOMER DRAWING SCALE: 4:1 SHEET: 1 OF 1 REV: H