

**Very Low Power 4-Output PCIe Clock Buffer With On-chip Termination**

**Features**

- 1.8V supply voltage
- HCSL input: 100MHz, also support 50MHz or 125MHz via SMBus
- 4 differential low power HCSL outputs with on-chip termination
- Individual output enable
- Programmable Slew rate and output amplitude for each output
- Differential outputs blocked until PLL is locked
- Strapping pins or SMBus for configuration;
- 3.3V tolerant SMBus interface support
- Very low jitter outputs
  - Differential cycle-to-cycle jitter <50ps
  - Differential output-to-output skew <50ps
  - PCIe Gen1/Gen2/Gen3/Gen4 compliant
- Packaging (Pb-free & Green): 32-lead 5x5mm TQFN

**Description**

The PI6CB18401 is an 4-output very low power PCIe Gen1/Gen2/Gen3/Gen4 clock buffer. It takes an reference input to fanout four 100MHz low power differential HCSL outputs with on-chip terminations. The on-chip termination can save 16 external resistors and make layout easier. Individual OE pin for each output provides easier power management.

It uses Pericom proprietary PLL design to achieve very low jitter that meets PCIe Gen1/Gen2/Gen3/Gen4 requirements. Other than PCIe 100MHz support, this device also support Ethernet application with 50MHz or 125MHz via SMBus. It provides various options such as different slew rate and amplitude through strapping pins or SMBUS so that users can configure the device easily to get the optimized performance for their individual boards.

**Block Diagram**

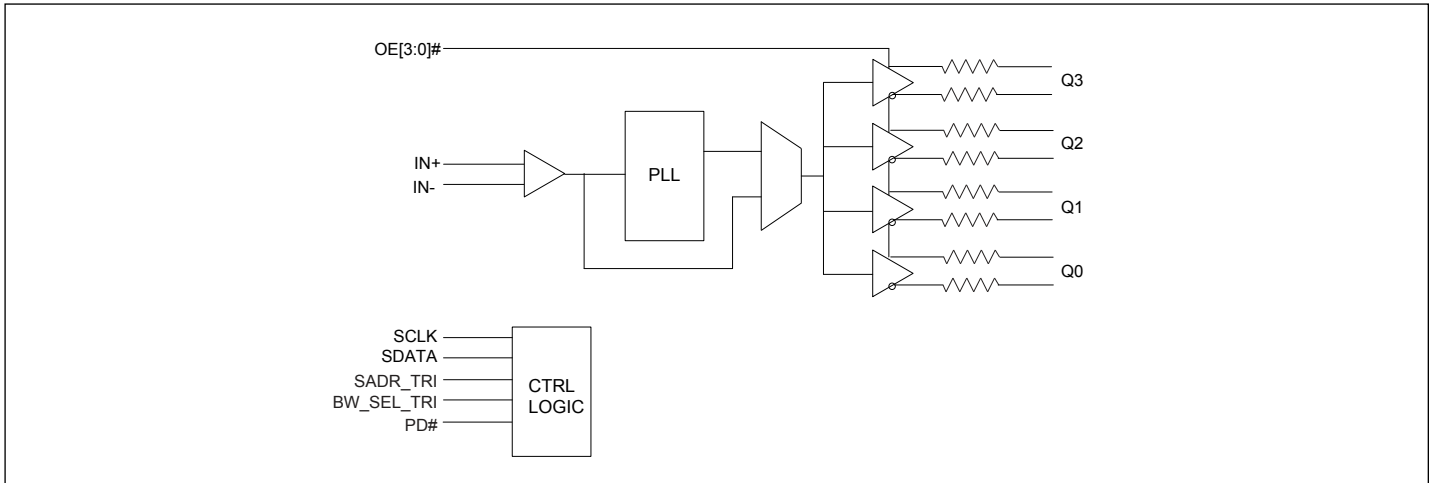

### Pin Configuration

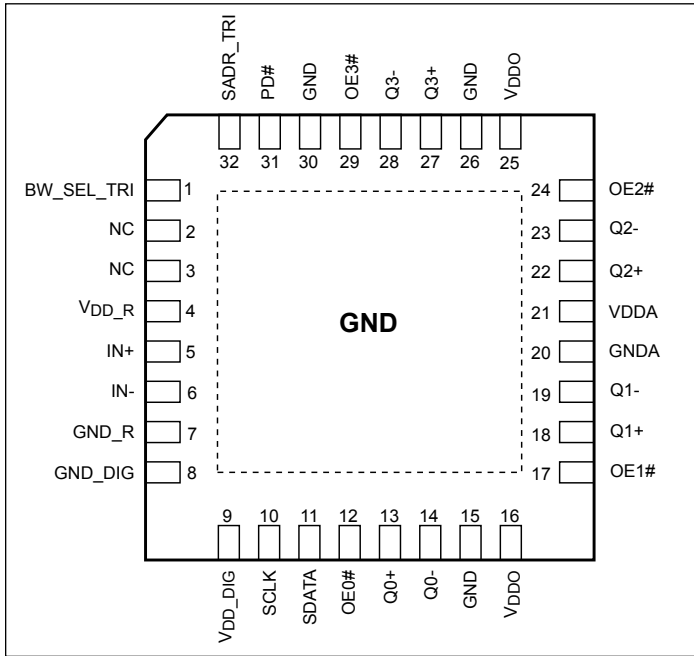

### Pin Description

Pin Number	Pin Name	Type		Description
1	BW_SEL_TRI	Input	Tri-level	Latch to select low loop bandwidth, bypass PLL, and high loop bandwidth. This pin has both internal pull-up and pull-down
2	NC			Internal connected for feedback loop. Do not connect this pin
3	NC			Internal connected for feedback loop. Do not connect this pin
4	VDD_R	Power		Power supply for input differential buffers
5	IN+	Input		Differential true clock input
6	IN-	Input		Differential complementary clock input
7	GND_R	Power		Ground for input differential buffers
8	GND_DIG	Power		Ground for digital circuitry
9	VDD_DIG	Power		Power supply for digital circuitry, nominal 1.8V
10	SCLK	Input	CMOS	SMBUS clock input, 3.3V tolerant
11	SDATA	Input/ Output	CMOS	SMBUS Data line, 3.3V tolerant
12	OE0#	Input	CMOS	Active low input for enabling Q0 pair. This pin has an internal pull-down. 1 =disable outputs, 0 = enable outputs
13	Q0+	Output	HCSL	Differential true clock output
14	Q0-	Output	HCSL	Differential complementary clock output
15, 26, 30	GND	Power		Ground
16, 25	VDDO	Power		Power supply for differential outputs
17	OE1#	Input	CMOS	Active low input for enabling Q1 pair. This pin has an internal pull-down. 1 =disable outputs, 0 = enable outputs

### Pin Description Cont.

Pin Number	Pin Name	Type		Description
18	Q1+	Output	HCSL	Differential true clock output
19	Q1-	Output	HCSL	Differential complementary clock output
20	GNDA	Power		Ground for analog circuitry
21	V <sub>DDA</sub>	Power		Power supply for analog circuitry
22	Q2+	Output	HCSL	Differential true clock output
23	Q2-	Output	HCSL	Differential complementary clock output
24	OE2#	Input	CMOS	Active low input for enabling Q2 pair. This pin has an internal pull-down. 1 =disable outputs, 0 = enable outputs
27	Q3+	Output	HCSL	Differential true clock output
28	Q3-	Output	HCSL	Differential complementary clock output
29	OE3#	Input	CMOS	Active low input for enabling Q3 pair. This pin has an internal pull-down. 1 =disable outputs, 0 = enable outputs
31	PD#	Input	CMOS	Input notifies device to sample latched inputs and start up on first high assertion. Low enters Power Down Mode, subsequent high assertions exit Power Down Mode. This pin has internal pull-up resistor.
32	SADR_TRI	Input	Tri-level	Latch to select SMBus Address. This pin has an internal pull-down

**PI6CB18401**

**SMBus Address Selection Table**

	SADR	Address	+Read/Write Bit
State of SADR on first application of PD#	0	1101011	X
	M	1101100	X
	1	1101101	X

**Power Management Table**

PD#	IN	SMBus OE bit	OEn#	Qn+	Qn-	PLL Status
0	X	X	X	Low	Low	Off
1	Running	0	X	Low	Low	On <sup>1</sup>
1	Running	1	0	Running	Running	On <sup>1</sup>
1	Running	1	1	Low	Low	On <sup>1</sup>

Note:

1. If PLL Bypass mode is selected, the PLL will be off and outputs will be running.

**PLL Operating Mode Select Table**

BW_SEL_TRI	Operating Mode	Byte1 [7:6] Readback	Byte1 [4:3] Readback
0	PLL with low Bandwidth	00	00
M	PLL Bypass	01	01
1	PLL with high Bandwidth	11	11

**Frequency Select table**

Freq. Select Byte 3 [4:3]	IN (MHz)	Qn (MHz)
00 (default)	100	100
01	50	50
10	125	125
11	Reserved	Reserved

## Maximum Ratings

(Above which useful life may be impaired. For user guidelines, not tested.)

Storage Temperature.....	-65°C to +150°C
Supply Voltage to Ground Potential, $V_{DDxx}$ .....	-0.5V to +2.5V
Input Voltage .....	-0.5V to $V_{DD}+0.5V$ , not exceed 2.5V
SMBus, Input High Voltage .....	3.6V
ESD Protection (HBM) .....	2000 V
Junction Temperature .....	125 °C max

**Note:**

Stresses greater than those listed under MAXIMUM RATINGS may cause permanent damage to the device. This is a stress rating only and functional operation of the device at these or any other conditions above those indicated in the operational sections of this specification is not implied. Exposure to absolute maximum rating conditions for extended periods may affect reliability.

## Operating Conditions

Temperature =  $T_A$ ; Supply voltages per normal operation conditions; See test circuits for the load conditions

Symbol	Parameters	Conditions	Min..	Typ.	Max.	Units
$V_{DD}, V_{DDA}, V_{DD\_R}, V_{DD\_DIG}$	Power Supply Voltage		1.7	1.8	1.9	V
$V_{DDO}$	Output Power Supply Voltage		1.7	1.8	1.9	V
$I_{DDA}$	Analog Power Supply Current	$V_{DDA} + V_{DD\_R}$ , PLL mode, All outputs active @100MHz		11	15	mA
$I_{DD}$	Power Supply Current	$V_{DD} + V_{DD\_DIG}$ , All outputs active @100MHz		8	10	mA
$I_{DDO}$	Power Supply Current for Outputs	All outputs active @100MHz		17	25	mA
$I_{DDA\_PD}$	Analog Power Supply Power Down <sup>1</sup> Current	$V_{DDA} + V_{DD\_R}$ , PLL mode, All outputs active @100MHz		0.7	1	mA
$I_{DD\_PD}$	Power Supply Power Down <sup>1</sup> Current	$V_{DD} + V_{DD\_DIG} + V_{DDO}$ , All outputs LOW/LOW			1.2	mA
$T_A$	Ambient Temperature	Commercial grade	0		70	°C
		Industrial grade	-40		85	

**Note:**

1. Input clock is not running.

## Input Electrical Characteristics

Symbol	Parameters	Conditions	Min.	Typ.	Max.	Units
$R_{pu}$	Internal pull up resistance			120		K $\Omega$
$R_{dn}$	Internal pull down resistance			120		K $\Omega$
$L_{PIN}$	Pin inductance				7	nH

## SMBus Electrical Characteristics

Temperature =  $T_A$ ; Supply voltages per normal operation conditions; See test circuits for the load conditions

Symbol	Parameters	Conditions	Min.	Typ.	Max.	Units
$V_{DDSMB}$	Nominal bus voltage		1.7		3.6	V
$V_{IHSMB}$	SMBus Input High Voltage	SMBus, $V_{DDSMB} = 3.3V$	2.1		3.6	V
		SMBus, $V_{DDSMB} < 3.3V$	0.65 $V_{DDSMB}$			
$V_{ILSMB}$	SMBus Input Low Voltage	SMBus, $V_{DDSMB} = 3.3V$			0.6	V
		SMBus, $V_{DDSMB} < 3.3V$			0.6	
$I_{SMBSINK}$	SMBus sink current	SMBus, at $V_{OLSMB}$	4			mA
$V_{OLSMB}$	SMBus Output Low Voltage	SMBus, at $I_{SMBSINK}$			0.4	V
$f_{MAXSMB}$	SMBus operating frequency	Maximum frequency			400	kHz
$t_{RMSB}$	SMBus rise time	(Max $V_{IL} - 0.15$ ) to (Min $V_{IH} + 0.15$ )			1000	ns
$t_{FMSB}$	SMBus fall time	(Min $V_{IH} + 0.15$ ) to (Max $V_{IL} - 0.15$ )			300	ns

## LVC MOS DC Electrical Characteristics

Temperature =  $T_A$ ; Supply voltages per normal operation conditions; See test circuits for the load conditions

Symbol	Parameters	Conditions	Min.	Typ.	Max.	Units
$V_{IH}$	Input High Voltage	Single-ended inputs, except SMBus	0.75 $V_{DD}$		$V_{DD}$ +0.3	V
$V_{IM}$	Input Mid Voltage	SADR_TRI, BW_SEL_TRI	0.4 $V_{DD}$	0.5 $V_{DD}$	0.6 $V_{DD}$	V
$V_{IL}$	Input Low Voltage	Single-ended inputs, except SMBus	-0.3		0.25 $V_{DD}$	V
$I_{IH}$	Input High Current	Single-ended inputs, $V_{IN} = V_{DD}$			20	mA
$I_{IL}$	Input Low Current	Single-ended inputs, $V_{IN} = 0V$	-20			$\mu A$
$I_{IH}$	Input High Current	Single-ended inputs with pull up / pull down resistor, $V_{IN} = V_{DD}$			220	mA
$I_{IL}$	Input Low Current	Single-ended inputs with pull up / pull down resistor, $V_{IN} = 0V$	-220			$\mu A$
$C_{IN}$	Input Capacitance		1.5		5	pF

## LVCMOS AC Electrical Characteristics

Temperature = T<sub>A</sub>; Supply voltages per normal operation conditions; See test circuits for the load conditions

Symbol	Parameters	Conditions	Min.	Typ.	Max.	Units
t <sub>OELAT</sub>	Output enable latency	Q start after OE# assertion Q stop after OE# deassertion	1		3	clocks
t <sub>PDLAT</sub>	PD# de-assertion	Differential outputs enable after PD# de-assertion		20	300	us

## HCSL Input Characteristics <sup>1</sup>

Temperature = T<sub>A</sub>; Supply voltages per normal operation conditions; See test circuits for the load conditions

Symbol	Parameters	Conditions	Min.	Typ.	Max.	Units
V <sub>IHDIF</sub>	Diff. Input High Voltage <sup>3</sup>	IN+, IN-, single-end measurement	600	800	1150	mV
V <sub>ILDIF</sub>	Diff. Input Low Voltage <sup>3</sup>	IN+, IN-, single-end measurement	-300	0	300	mV
V <sub>COM</sub>	Diff. Input Common Mode Voltage		150		1000	mV
V <sub>SWING</sub>	Diff. Input Swing Voltage	Peak to peak value (V <sub>IHDIF</sub> - V <sub>ILDIF</sub> )	300		1450	mV
f <sub>INBP</sub>	Input Frequency	PLL Bypass mode	1		200	MHz
f <sub>IN100</sub>	Input Frequency	100MHz PLL	60	100	110	MHz
f <sub>IN125</sub>	Input Frequency	125MHz PLL	75	125	137.5	MHz
f <sub>IN156</sub>	Input Frequency	50MHz PLL	30	50	65	MHz
t <sub>STAB</sub>	Clock stablization	From V <sub>DD</sub> Power-Up and after input clock stabilization or de-assertion of PD# to 1st clock		0.6	1.0	ms
t <sub>RF</sub>	Diff. Input Slew Rate <sup>2</sup>	Measured differentially	0.4			V/ns
I <sub>IN</sub>	Diff. Input Leakage Current	V <sub>IN</sub> = V <sub>DD</sub> , V <sub>IN</sub> = GND	-5	0.01	5	uA
t <sub>DC</sub>	Diff. Input Duty Cycle	Measured differentially	45		55	%
t <sub>jC-c</sub>	Diff. Input Cycle to cycle jitter	Measured differentially			125	ps

**Note:**

1. Guaranteed by design and characterization, not 100% tested in production
2. Slew rate measured through +/-75mV window centered around differential zero
3. The device can be driven by a single-ended clock by driving the true clock and biasing the complement clock input to the V<sub>bias</sub>, where V<sub>bias</sub> is (V<sub>IH</sub>-V<sub>IL</sub>)/2

## HCSL Output Characteristics

Temperature =  $T_A$ ; Supply voltages per normal operation conditions; See test circuits for the load conditions

Symbol	Parameters	Condition	Min.	Typ.	Max.	Units
$V_{OH}$	Output Voltage High <sup>1</sup>	Statistical measurement on single-ended signal using oscilloscope math function	660	774	900	mV
$V_{OL}$	Output Voltage Low <sup>1</sup>		-150		150	mV
$V_{OMAX}$	Output Voltage Maximum <sup>1</sup>	Measurement on single ended signal using absolute value		821	1150	mV
$V_{OMIN}$	Output Voltage Minimum <sup>1</sup>		-300	-15		mV
$V_{OSWING}$	Output Swing Voltage <sup>1,2,3</sup>	Scope averaging off	300	1536		mV
$V_{OC}$	Output Cross Voltage <sup>1,2,4</sup>		250	430	550	mV
$DV_{OC}$	$V_{OC}$ Magnitude Change <sup>1,2,5</sup>			12	140	mV

### Note:

1. At default SMBUS amplitude settings
2. Guaranteed by design and characterization, not 100% tested in production
3. Measured from differential waveform
4. This one is defined as voltage where  $Q+ = Q-$  measured on a component test board and only applied to the differential rising edge
5. The total variation of all  $V_{cross}$  measurements in any particular system. This is a subset of  $V_{cross\_min/max}$  allowed.

## HCSL Output AC Characteristics

Temperature =  $T_A$ ; Supply voltages per normal operation conditions; See test circuits for the load conditions

Symbol	Parameters	Condition	Min.	Typ.	Max.	Units
$f_{OUT}$	Output Frequency			100		MHz
BW	PLL bandwidth <sup>1,8</sup>	-3dB point in High Bandwidth Mode	2	2.7	4	MHz
		-3dB point in Low Bandwidth Mode	1	1.4	2	MHz
$t_{jpeak}$	PLL Jitter Peaking	Peak pass band gain		1.2	2	dB
$t_{RF}$	Slew rate <sup>1,2,3</sup>	Scope averaging on fast setting	2.2	3	6.5	V/ns
		Scope averaging on slow setting	0.4	2	3	V/ns
$Dt_{RF}$	Slew rate matching <sup>1,2,4</sup>	Scope averaging on		7	20	%
$t_{SKEW}$	Output Skew <sup>1,2</sup>	Averaging on, $V_T = 50\%$		43	50	ps
$t_{PDELAY}$	Propagation delay	PLL Bypass mode, $V_T = 50\%$	3000	3600	4500	ps
		PLL mode, $V_T = 50\%$	0	90	200	ps
$t_{j-c-c}$	Cycle to cycle jitter <sup>1,2</sup>			14	50	ps
$t_{jPHASE}$	Integrated phase jitter (RMS) <sup>1,5,6</sup>	PCIe Gen 1	20	22	86	ps
		PCIe Gen 2 Low Band, $10kHz < f < 1.5MHz$	0.2	0.3	3.0	ps
		PCIe Gen 2 High Band, $1.5MHz < f < Nyquist (50MHz)$	1.6	2.0	3.1	ps
		PCIe Gen 3 (PLL BW of 2-4 or 2-5MHz, CDR =10MHz)	0.3	0.35	1.0	ps
		125MHz, 1.5MHz to 20MHz, -20dB/decade Rollover $< 1.5MHz$ , -40dB/decade rolloff $> 10MHz$ <sup>9</sup>		1.9	2	ps



### HC SL Output AC Characteristics Cont.

Symbol	Parameters	Condition	Min.	Typ.	Max.	Units
t <sub>JPHASEA</sub>	Additive Integrated phase jitter (RMS) <sup>1,5,10</sup>	PCIe Gen 1		0.6	5	ps
		PCIe Gen 2 Low Band, 10kHz < f < 1.5MHz		0.1	0.3	ps
		PCIe Gen 2 High Band, 1.5MHz < f < Nyquist (50MHz)		0.05	0.1	ps
		PCIe Gen 3 (PLL BW of 2-4 or 2-5MHz, CDR =10MHz)		0.05	0.1	ps
		PCIe Gen 4 (PLL BW of 2-4 or 2-5MHz, CDR =10MHz) (BW_SEL_TRI=M)		0.03	0.05	ps
		125MHz, 1.5MHz to 20MHz, -20dB/decade Rollover < 1.5MHz, -40dB/decade rolloff > 10MHz		0.15	0.3	ps
t <sub>DC</sub>	Duty Cycle <sup>1,2</sup>	Measured differentially, PLL Mode	45	50	55	%
t <sub>DCCD</sub>	Duty Cycle Distortion <sup>1,7</sup>	Measured differentially, PLL Bypass Mode at 100MHz	-1	0	1	%
t <sub>STARTUP</sub>	Start up time				10	ms
t <sub>LOCK</sub>	PLL lock time				20	ms

**Note:**

1. Guaranteed by design and characterization, not 100% tested in production
2. Measured from differential waveform
3. Slew rate is measured through the V<sub>swing</sub> voltage range centered around differential 0V, within +/-150mV window
4. Slew rate matching is measured using a +/-75mV window centered at differential zero
5. See <http://www.pcisig.com> for complete specs
6. Sample size of at least 100k cycles. This can be extrapolated to 108ps pk-pk @ 1M cycles for a BER of 10<sup>-12</sup>
7. Duty cycle distortion is the difference in duty cycle between the out and input clock when the device is operated in the PLL bypass mode
8. The Min and Max values of each BW setting track each other, low BW max will never occur with high BW min
9. Applies to all differential outputs
10. For additive jitter RMS value is calculated by the following equation = SQRT [(total jitter)<sup>2</sup> - (input jitter)<sup>2</sup>]

## SMBus Serial Data Interface

PI6CB18401 is a slave only device that supports block read and block write protocol using a single 7-bit address and read/write bit as shown below.

Read and write block transfers can be stopped after any complete byte transfer.

### Address Assignment

A6	A5	A4	A3	A2	A1	A0	R/W
1	1	0	1	See SBMbus Address Selection table			1/0

Note: SMBus address is latched on SADR pin

### How to Write

1 bit	7 bits	1 bit	1 bit	8 bits	1 bit	8 bits	1 bit	8 bits	1 bit		8 bits	1 bit	1 bit
Start bit	Add.	W(0)	Ack	Beginning Byte location = N	Ack	Data Byte count = X	Ack	Beginning Data Byte (N)	Ack	.....	Data Byte (N+X-1)	Ack	Stop bit

### How to Read

1 bit	7 bits	1 bit	1 bit	8 bits	1 bit	1 bit	7 bits	1 bit	1 bit	8 bits	1 bit	8 bits	1 bit
Start bit	Address	W(0)	Ack	Beginning Byte location = N	Ack	Repeat Start bit	Address	R(1)	Ack	Data Byte count = X	Ack	Beginning Data Byte (N)	Ack

	8 bits	1 bit	1 bit
.....	Data Byte (N+X-1)	NAck	Stop bit

### Byte 0: Output Enable Register <sup>1</sup>

Bit	Control Function	Description	Type	Power Up Condition	0	1
7	Reserved			1		
6	Q3_OE	Q6 output enable	RW	1	Low/Low	Enabled
5	Q2_OE	Q5 output enable	RW	1	Low/Low	Enabled
4	Reserved			1		
3	Q1_OE	Q3 output enable	RW	1	Low/Low	Enabled
2	Reserved			1		
1	Q0_OE	Q1 output enable	RW	1	Low/Low	Enabled
0	Reserved			1		

**Note:**

1. A low on these bits will override the OE# pins and force the differential outputs to Low/Low states

### Byte 1: PLL Pperating Mode and Output Amplitude Control Register

Bit	Control Function	Description	Type	Power Up Condition	0	1
7	PLLMODERB1	PLL Mode Readback Bit1	R	Latch	See PLL Operating Mode Table	
6	PLLMODERB0	PLL Mode Readback Bit0	R	Latch		
5	PLLMODE_SWCTR	Enable SW control of PLL Mode	RW	0	Values in B1[7:6] set PLL Mode	Values in B1[4:3] set PLL Mode
4	PLLMODE1	PLL Mode control Bit1	RW <sup>1</sup>	0	See PLL Operating Mode Table	
3	PLLMODE0	PLL Mode control Bit0	RW <sup>1</sup>	0		
2	Reserved			1		
1	Amplitude1	Control output applitude	RW	1	'00' = 0.6V, '01' = 0.7V, '10' = 0.8V, '11' = 0.9V	
0	Amplitude0		RW	0		

**Note:**

1. B1[5] must be set to a 1 for these bits to have any effect on the part

### Byte 2: Differential Output Slew Rate Control Register

Bit	Control Function	Description	Type	Power Up Condition	0	1
7	Reserved			1		
6	SLEWRATECTR_Q3	Control slew rate of Q6	RW	1	Slow setting	Fast setting
5	SLEWRATECTR_Q2	Control slew rate of Q5	RW	1	Slow setting	Fast setting
4	Reserved			1		
3	SLEWRATECTR_Q1	Control slew rate of Q3	RW	1	Slow setting	Fast setting
2	Reserved			1		
1	SLEWRATECTR_Q0	Control slew rate of Q1	RW	1	Slow setting	Fast setting
0	Reserved			1		

### Byte 3: Frequency Select Control Register

Bit	Control Function	Description	Type	Power Up Condition	0	1
7	Reserved			1		
6	Reserved			1		
5	FREQ_SEL_EN	Enable SW selection of frequency	RW	0	SW Freq. selection disabled	SW Freq. selection enabled
4	FSEL1	Freq. Select Bit 1	RW <sup>1</sup>	0	See Frequency Select Table	
3	FSEL0	Freq. Select Bit 0	RW <sup>1</sup>	0		
2	Reserved			1		
1	Reserved			1		
0	SLEWRATESEL_FB	Adjust Slew Rate of Feedback signal	RW	1	2.0V/ns	3.0V/ns

**Note:**

1. B1[5] must be set to a 1 for these bits to have any effect on the part

### Byte 4: Reserved

Bit	Control Function	Description	Type	Power Up Condition	0	1
7:0	Reserved			1		

### Byte 5: Revision and Vendor ID Register

Bit	Control Function	Description	Type	Power Up Condition	0	1
7	RID3	Revision ID	R	0	rev = 0000	
6	RID2		R	0		
5	RID1		R	0		
4	RID0		R	0		
3	PVID3	Vendor ID	R	0	Pericom = 0011	
2	PVID3		R	0		
1	PVID3		R	1		
0	PVID3		R	1		

### Byte 6: Device Type/Device ID Register

Bit	Control Function	Description	Type	Power Up Condition	0	1
7	DTYPE1	Device type	R	0	'00' = CG, '01' = ZDB, '10' = Reserve, '11' = ZDB	
6	DTYPE0		R	1		
5	DID5	Device ID	R	0	000100 binary, 04Hex	
4	DID4		R	0		
3	DID3		R	0		
2	DID2		R	1		
1	DID1		R	0		
0	DID0		R	0		

### Byte 7: Byte Count Register

Bit	Control Function	Description	Type	Power Up Condition	0	1
7	Reserved			0		
6	Reserved			0		
5	Reserved			0		
4	BC4	Byte count programming	RW	0	Writing to this register will configure how many bytes will be read back, default is 8 bytes	
3	BC3		RW	1		
2	BC2		RW	0		
1	BC1		RW	0		
0	BC0		RW	0		

**Plots**  
**100MHz HCSL Clock**

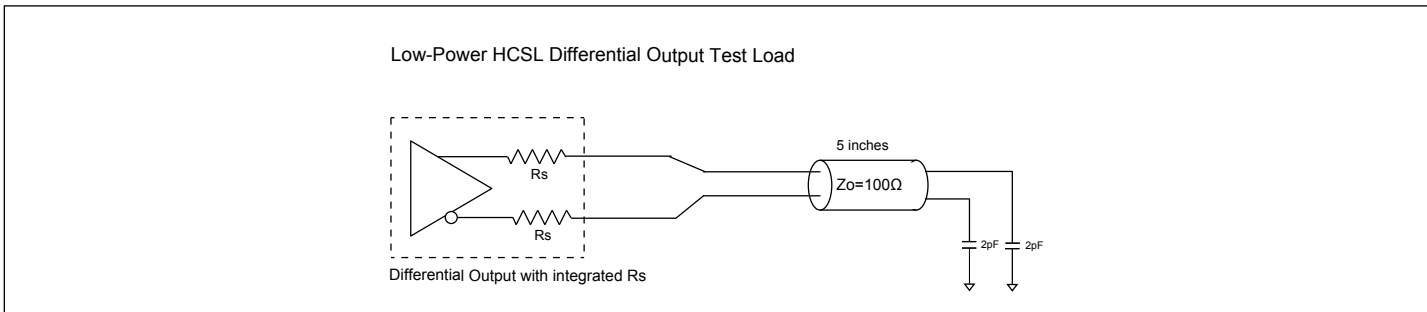
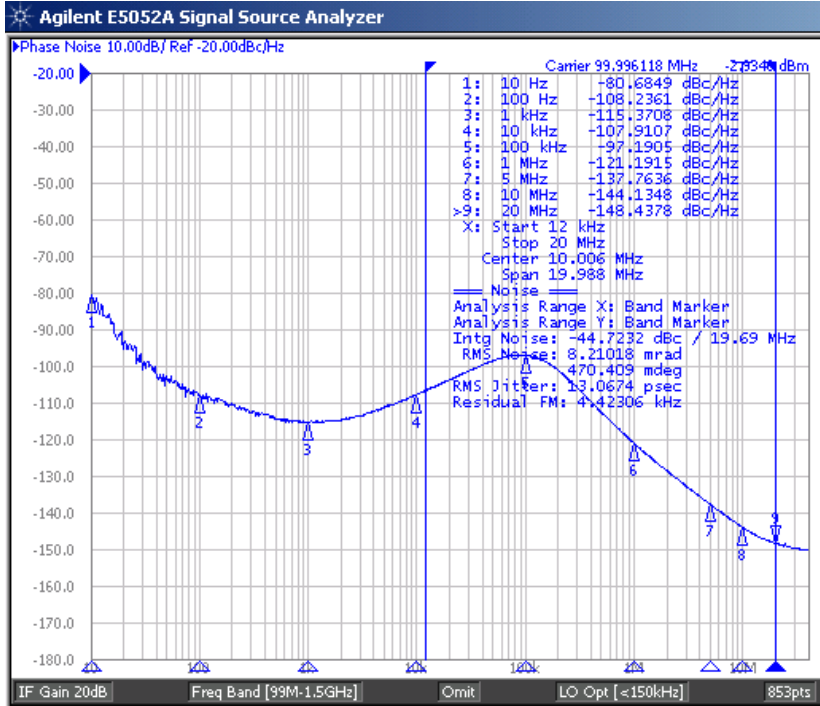

**Figure 1. Low Power HCSL Test Circuit**

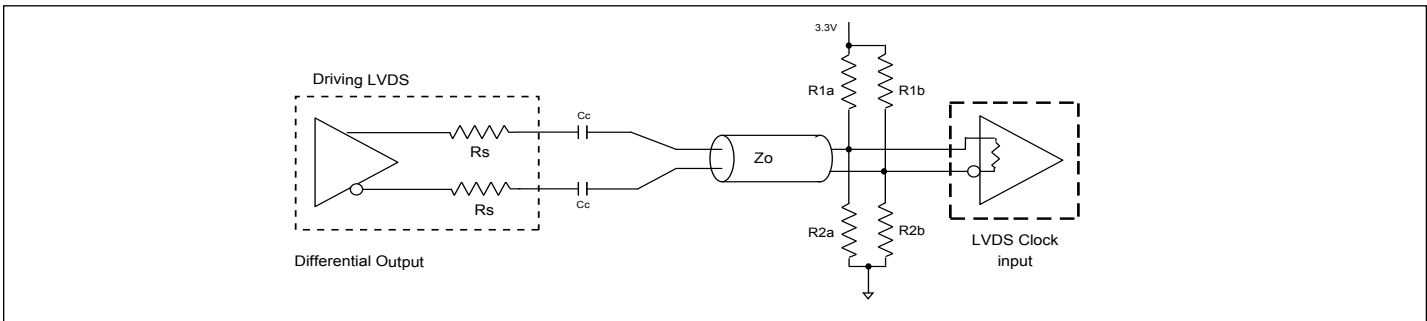
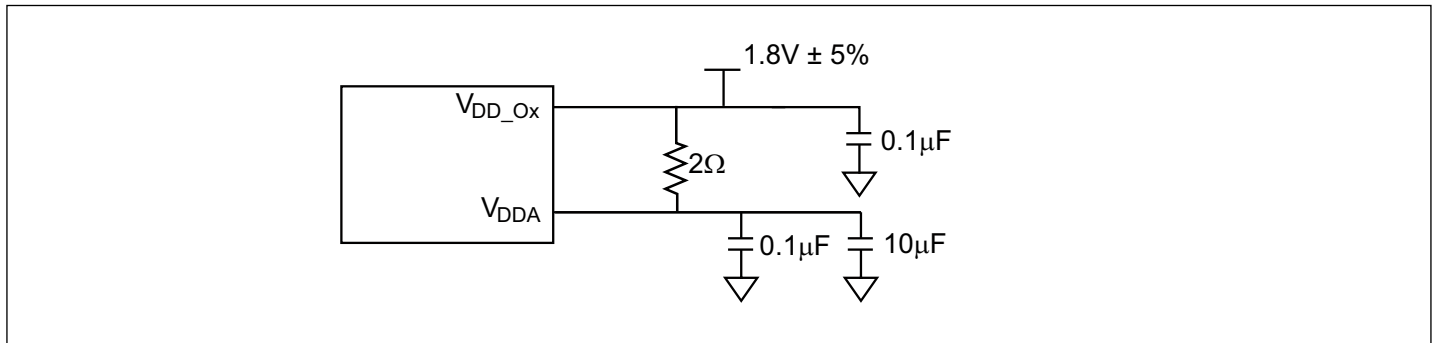

**Figure 2. Differential Output driving LVDS**

**PI6CB18401**

**Alternate Differential Output Terminations**

Component	Receiver with termination	Receiver without termination	Unit
R <sub>1a</sub> , R <sub>1b</sub>	10,000	140	Ω
R <sub>2a</sub> , R <sub>2b</sub>	5,600	75	Ω
C <sub>C</sub>	0.1	0.1	μF
V <sub>CM</sub>	1.2	1.2	V



**Figure 3. Power Supply Filter**

**Part Marking**

ZH Package

PI6CB18  
401ZHIE  
ZYYWWXX  
○

Z: Die Rev

YY: Year

WW: Workweek

1st X: Assembly Code

2nd X: Fab Code

**PI6CB18401**

**Packaging Mechanical: 32-TQFN (ZH)**

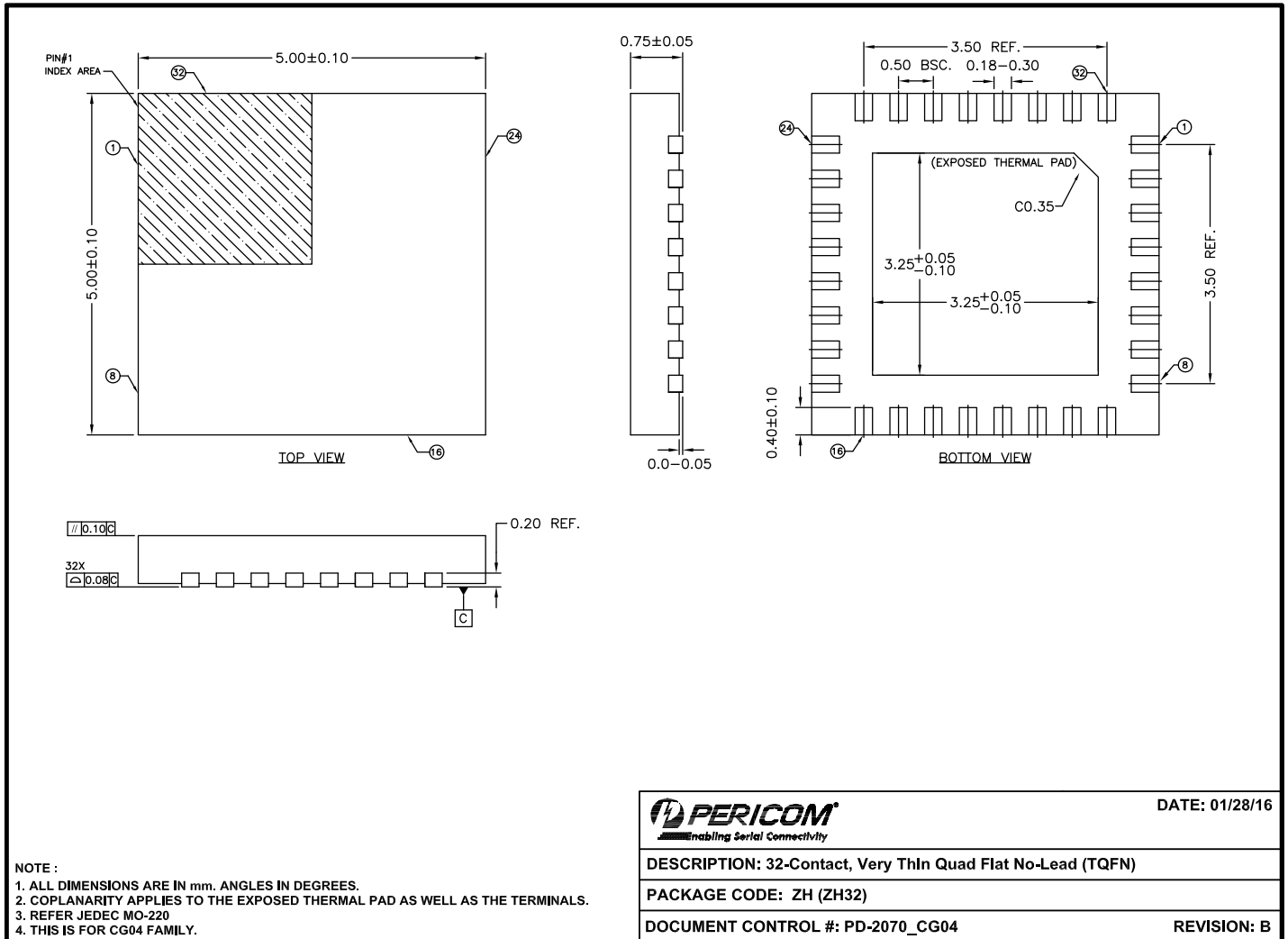

For latest package info,  
please check: <http://www.diodes.com/design/support/packaging/pericom-packaging/packaging-mechanicals-and-thermal-characteristics/>

**Ordering Information<sup>(1-3)</sup>**

Ordering Code	Package Code	Package Description	Operating Temperature
PI6CB18401ZHIEX	ZH	32-Contact, Very Thin Quad Flat No-Lead (TQFN)	Industrial

**Notes:**

1. EU Directive 2002/95/EC (RoHS), 2011/65/EU (RoHS 2) & 2015/863/EU (RoHS 3) compliant. All applicable RoHS exemptions applied.
2. See <http://www.diodes.com/quality/lead-free/> for more information about Diodes Incorporated's definitions of Halogen- and Antimony-free, "Green" and Lead-free. Thermal characteristics can be found on the company web site at [www.diodes.com/design/support/packaging/](http://www.diodes.com/design/support/packaging/)
3. E = Pb-free and Green
4. X suffix = Tape/Reel



**IMPORTANT NOTICE**

DIODES INCORPORATED MAKES NO WARRANTY OF ANY KIND, EXPRESS OR IMPLIED, WITH REGARDS TO THIS DOCUMENT, INCLUDING, BUT NOT LIMITED TO, THE IMPLIED WARRANTIES OF MERCHANTABILITY AND FITNESS FOR A PARTICULAR PURPOSE (AND THEIR EQUIVALENTS UNDER THE LAWS OF ANY JURISDICTION).

Diodes Incorporated and its subsidiaries reserve the right to make modifications, enhancements, improvements, corrections or other changes without further notice to this document and any product described herein. Diodes Incorporated does not assume any liability arising out of the application or use of this document or any product described herein; neither does Diodes Incorporated convey any license under its patent or trademark rights, nor the rights of others. Any Customer or user of this document or products described herein in such applications shall assume all risks of such use and will agree to hold Diodes Incorporated and all the companies whose products are represented on Diodes Incorporated website, harmless against all damages.

Diodes Incorporated does not warrant or accept any liability whatsoever in respect of any products purchased through unauthorized sales channel.

Should Customers purchase or use Diodes Incorporated products for any unintended or unauthorized application, Customers shall indemnify and hold Diodes Incorporated and its representatives harmless against all claims, damages, expenses, and attorney fees arising out of, directly or indirectly, any claim of personal injury or death associated with such unintended or unauthorized application.

Products described herein may be covered by one or more United States, international or foreign patents pending. Product names and markings noted herein may also be covered by one or more United States, international or foreign trademarks.

This document is written in English but may be translated into multiple languages for reference. Only the English version of this document is the final and definitive format released by Diodes Incorporated.

**LIFE SUPPORT**

Diodes Incorporated products are specifically not authorized for use as critical components in life support devices or systems without the express written approval of the Chief Executive Officer of Diodes Incorporated. As used herein:

A. Life support devices or systems are devices or systems which:

1. are intended to implant into the body, or

2. support or sustain life and whose failure to perform when properly used in accordance with instructions for use provided in the labeling can be reasonably expected to result in significant injury to the user.

B. A critical component is any component in a life support device or system whose failure to perform can be reasonably expected to cause the failure of the life support device or to affect its safety or effectiveness.

Customers represent that they have all necessary expertise in the safety and regulatory ramifications of their life support devices or systems, and acknowledge and agree that they are solely responsible for all legal, regulatory and safety-related requirements concerning their products and any use of Diodes Incorporated products in such safety-critical, life support devices or systems, notwithstanding any devices- or systems-related information or support that may be provided by Diodes Incorporated. Further, Customers must fully indemnify Diodes Incorporated and its representatives against any damages arising out of the use of Diodes Incorporated products in such safety-critical, life support devices or systems.

Copyright © 2016, Diodes Incorporated

[www.diodes.com](http://www.diodes.com)