

PART NUMBER	REVISION	DESCRIPTION	FEED TYPE
2150046-2	J	FINE CRIMP HEIGHT ADJUST	PNEUMATIC
7-2150046-2	J	PNEUMATIC AND CRIMP TOOLING KIT	PNEUMATIC
7-2150046-7	B	CRIMP TOOLING KIT	-

ATLANTIC VERSION TERMINATOR INTERFACE ADAPTER

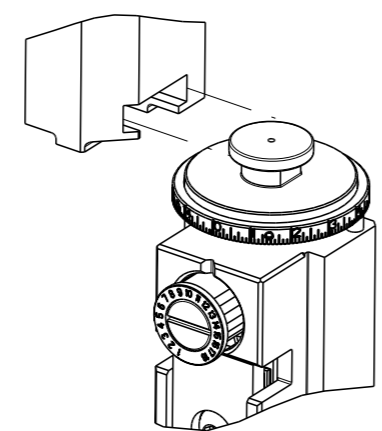

APPLICATOR DATA		
CRIMP	SIZE	TYPE
WIRE	2.79 mm [.110]	F
INSUL	4.06 mm [.160]	F

APPLICATOR INSTRUCTIONS 408-35043

TERMINAL DATA: TE TERMINAL		TE CRIMP SPECIFICATION	
TERMINAL NAME: .250 SERIES FASTIN-FASTON TAB			
WIRE STRIP LENGTH		INSULATION DIAMETER RANGE	
5.41-6.07 mm [.213-.239 IN]		Ø3.05-4.32 mm [.120-.170 IN]	
TERMINAL APPLICATION SPECIFICATION	(A)114-2025	-	-
TERMINALS APPLIED			
TE TERMINAL	TE TERMINAL	TE TERMINAL	TE TERMINAL
(A) 42099-2	(A) 160450-5	(A) 160457-1	(A) 160740-1
(A) 42580-2	(A) 160452-1	(A) 160457-2	(A) 160740-2
(A) 160450-1	(A) 160452-2	(A) 160457-3	(A) 170151-1
(A) 160450-2		(A) 160459-1	(A) 170151-2
(A) 160450-3		(A) 160459-3	(A) 170151-3

TERMINAL DATA: TE TERMINAL		TE CRIMP SPECIFICATION	
TERMINAL NAME: .250 SERIES FASTIN-FASTON TAB			
WIRE STRIP LENGTH		INSULATION DIAMETER RANGE	
5.41-6.07 mm [.213-.239 IN]		Ø3.05-4.32 mm [.120-.170 IN]	
TERMINAL APPLICATION SPECIFICATION	(B)114-20021	-	-
TERMINALS APPLIED			
TE TERMINAL	TE TERMINAL	TE TERMINAL	TE TERMINAL
(B) 42098-1	(B) 42460-5	(B) 280081-6	(B) 1-280081-2
(B) 42098-2	(B) 42460-6	(B) 280081-7	
(B) 42098-3	(B) 280081-1	(B) 280081-8	
(B) 42460-1	(B) 280081-2	(B) 280081-9	
(B) 42460-2	(B) 280081-3	(B) 1-280081-0	
(B) 42460-3	(B) 280081-4	(B) 1-280081-1	

WIRE SIZE	CRIMP HEIGHT mm [INCH]	CRIMP HEIGHT REFERENCE SETTING
14 AWG	1.93+/-0.05 [.076+/-0.002]	3.2
2.50mm2	1.91+/-0.05 [.075+/-0.002]	3.4
16 AWG	1.70+/-0.05 [.067+/-0.002]	5.7
1.50mm2	1.65+/-0.05 [.065+/-0.002]	6.2
18 AWG	1.55+/-0.05 [.061+/-0.002]	7.2
1.00mm2	1.52+/-0.05 [.060+/-0.002]	7.5

WIRE SIZE	CRIMP HEIGHT mm [INCH]	CRIMP HEIGHT REFERENCE SETTING
2.50mm2	1.91+/-0.05 [.075+/-0.002]	3.4
2x 0.75mm2	1.65+/-0.05 [.065+/-0.002]	6.0
1.50mm2	1.65+/-0.05 [.065+/-0.002]	6.0
1.00mm2	1.52+/-0.05 [.060+/-0.002]	6.7
0.75mm2	1.45+/-0.05 [.057+/-0.002]	8.4

- △ RECOMMENDED SPARE PARTS
- △ REFER TO SUPPLIED INSTRUCTION SHEET FOR CLEANING, LUBRICATION AND STORAGE OF APPLICATOR.
- △ APPLY PART NUMBER 2-23419-6 LOCTITE TO THREADS OF ITEM 242. APPLY PART NUMBER 1-23419-5 LOCTITE TO THREADS OF ITEM 50.
- △ CRIMP HEIGHT REFERENCE SETTING WAS THE SETTING USED WHEN THE APPLICATOR WAS QUALIFIED AT THE FACTORY. ADJUSTMENT MAY BE NECESSARY WHEN RUNNING APPLICATOR IN THE FIELD.
- △ TERMINAL PITCH NOT COMPATIBLE WITH MECHANICAL FEED.
- 6. UNLESS SPECIFIED OTHERWISE TORQUE VALUES SHALL BE USED PER DOCUMENT, 101-35000.

***WARNING**
ON INSTALLATION, SET WIRE DISC TO CRIMP HEIGHT REFERENCE SETTING FOR LARGEST WIRE SIZE. CRIMP HEIGHT REFERENCE SETTINGS GREATER THAN THE VALUE SHOWN MAY CAUSE DAMAGE TO THE CRIMP TOOLING. REFER TO THE INSTRUCTION SHEET FOR PROPER SETUP AND ADJUSTMENTS.

ATLANTIC VERSION
Shown on sheets 1 of 4 & 2 of 4
(Pacific version shown on sheets 3 of 4 & 4 of 4)

LOC	DIST	REVISIONS			
		REV	DATE	BY	CHK
A	66	F	15MAR2017	TB	CT
		G	29SEP2018	TB	TE
		H	17APR2019	FL	CT
		J	03JUN2019	LG	TE

-	1	1	2119641-1	FEED CAM, AIR FEED	248
-	1	1	2119082-9	CAM, SNAIL, INSULATION ADJUSTMENT	244
-	1	1	2079764-1	WASHER, WAVE SPRING, CREST-TO-CREST	243
-	1	1	2119083-1	RETAINER, INSULATION DIAL	242
-	1	1	2844940-4	AIR FEED MODULE	238
-	1	1	1-18028-0	WASHER, FLAT, REG M8	192
-	1	1	6-993111-6	PIN, SLOTTED SPRING 3.0 X 14.0	177
-	1	1	8-22280-7	SPRING, COMPRESSION	176
-	1	1	1752353-2	GUIDE PIN,HOLDDOWN	175
-	1	1	1901680-2	GUIDE PIN,HOLDDOWN	174
-	REF	REF	994970-2	COUNTER, MAGNETIC	164
-	1	1	455888-5	SPACER, CRIMPER	82
-	1	1	1803607-4	DOCUMENTATION PACKAGE	71
-	2	2	2-18032-2	SCR, SET, FLT PNT, M3 X 10.0	70
-	1	1	2119740-1	TAG, IDENTIFICATION	67
-	2	2	2168078-1	SCREW, DRIVE, RH, RoHS, 2 x .188	66
-	1	1	1976052-1	HOLDDOWN, TERMINAL	65
-	1	1	2168083-2	SCR, SKT HD CAP, RoHS, M4 X 8.0	60
-	1	1	5-18022-5	SCR, HEX HD CAP, M4 X 6.0	59
-	4	4	2168400-4	SHCS, LOW HEAD, RoHS, M4 X 8	57
-	2	2	2168083-9	SCR, SKT HD CAP, RoHS, M4 X 20	56
-	2	2	5018030-1	NUT, HEX, REG, RoHS, M3	54
-	2	2	986965-8	NUT, LOCK, HEX, TORQUE (M4)	53
-	1	1	1-5018030-0	NUT, HEX, REG, RoHS, M3.5	52
-	1	1	2063961-1	FEED FINGER	51
-	1	1	1752354-2	STANDOFF,HOLD-DOWN	50
-	1	1	18023-9	SCR, SKT HD CAP M4 X 6.0	49
-	1	1	2119655-5	APPLICATOR BASIC ASSEMBLY, EF	46
-	1	1	1803517-1	RAM ASSEMBLY, EF ATLANTIC	44
-	1	1	1803602-1	SCR, BHSC, RoHS (M8 X 25)	41
-	8	8	1-18028-2	WASHER, FLAT, REG M4	33
-	2	2	2168083-9	SCR, SKT HD CAP, RoHS, M4 X 20	31
-	2	2	2168083-2	SCR, SKT HD CAP, RoHS, M4 X 8.0	29
-	1	1	240639-1	STRIPPER (MACHINING)	27
-	2	2	1-2168083-5	SCR, SKT HD CAP, RoHS, M4 X 30	25
-	1	1	1752371-5	PLATE, STRIP GUIDE	24
-	2	2	2-22281-3	SPRING, COMPRESSION	22
-	1	1	1803292-4	DRAG	20
-	1	1	1-1901696-9	STRIP GUIDE, REAR	19
-	1	1	1-1901695-9	STRIP GUIDE, FRONT	18
-	4	4	1-2079383-1	SCR, BHSC, RoHS (M6 X 12)	17
-	1	1	6-240641-5	SPACER	16
-	1	1	1752360-1	SPACER,HOLD-DOWN	13
-	1	1	240644-1	PLATE, REAR SHEAR	11
-	-	-	-	-	10
-	1	1	690482-4	PLATE, FRONT SHEAR	9
-	1	2	1333219-4	ANVIL, COMBINATION	8
-	1	1	1-690474-7	BLADE, SLUG	7
-	-	-	-	-	6
-	1	1	2-240641-7	SPACER	5
-	1	1	238011-2	BLOCK, CRIMPER SPACER	4
-	1	2	3-2119582-4	CRIMPER, INSULATION F PREMIUM	3
-	1	1	1-455888-0	SPACER, CRIMPER	2
-	1	2	456408-5	CRIMPER, WIRE PREMIUM	1
-	77	72	2	PART NO	ITEM NO

DIMENSIONS:		TOLERANCES UNLESS OTHERWISE SPECIFIED:		MATERIAL:	
mm	0 PLC ±	1 PLC ±	2 PLC ±	3 PLC ±	4 PLC ±
	ANGLES	FINISH			

OWN	Y. YIN	06FEB2012	NAME	Ocean End Feed Applicator	
CHK	G. BAILEY	06FEB2012	SIZE	CAGE CODE	DRAWING NO
APVD	S. YI	06FEB2012	SCALE	1:1	SHEET 1 OF 4
PRODUCT SPEC			RESTRICTED TO		
APPLICATION SPEC			WEIGHT		
Customer Accessible Production Drawing			SCALE	1:1	SHEET 1 OF 4

LOC	DIST	REVISIONS					
A	66	P	LYR	DESCRIPTION	DATE	OWN	APVD
		-		SEE SHEET 1			

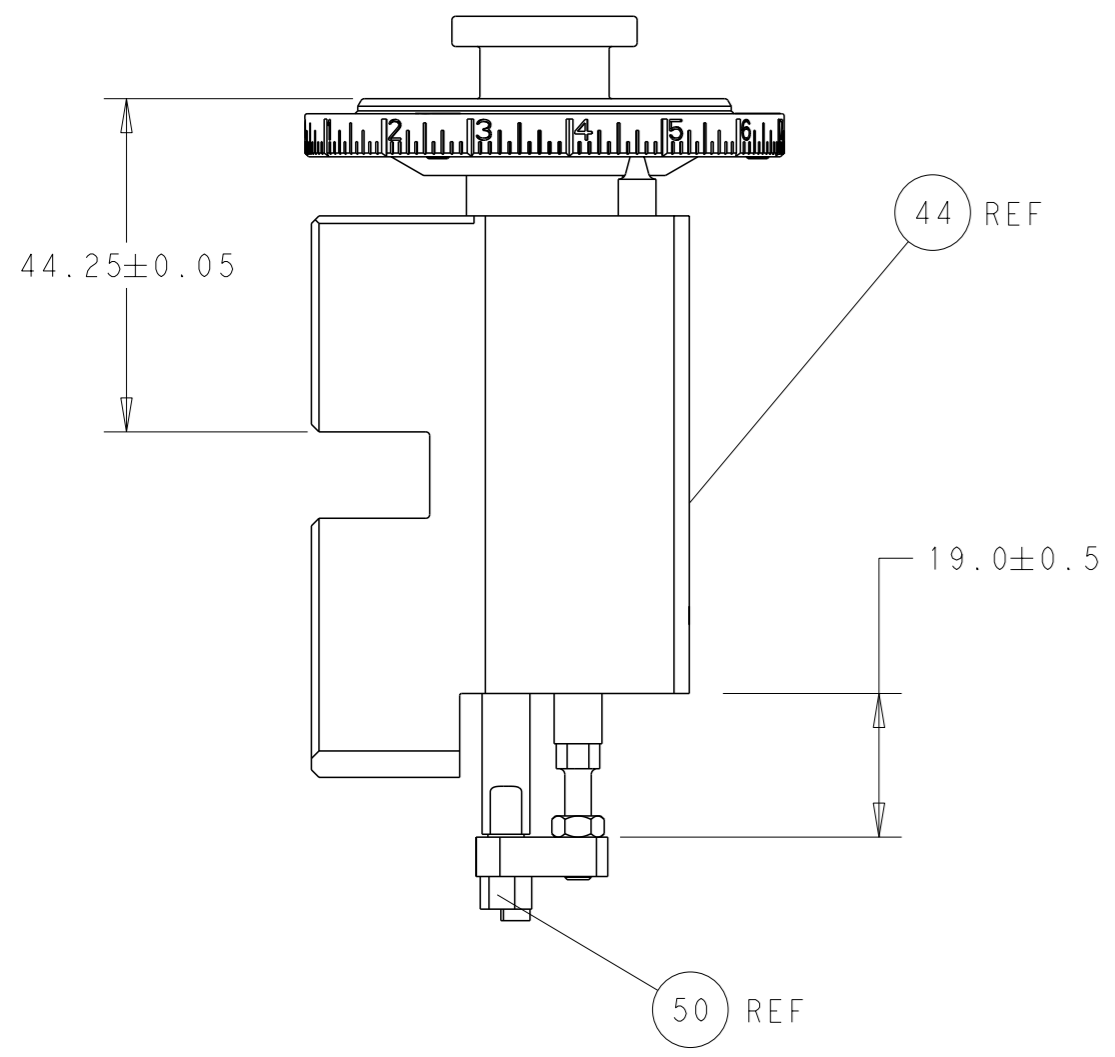

RAM AND HOLDDOWN SET-UP

FEED TYPE

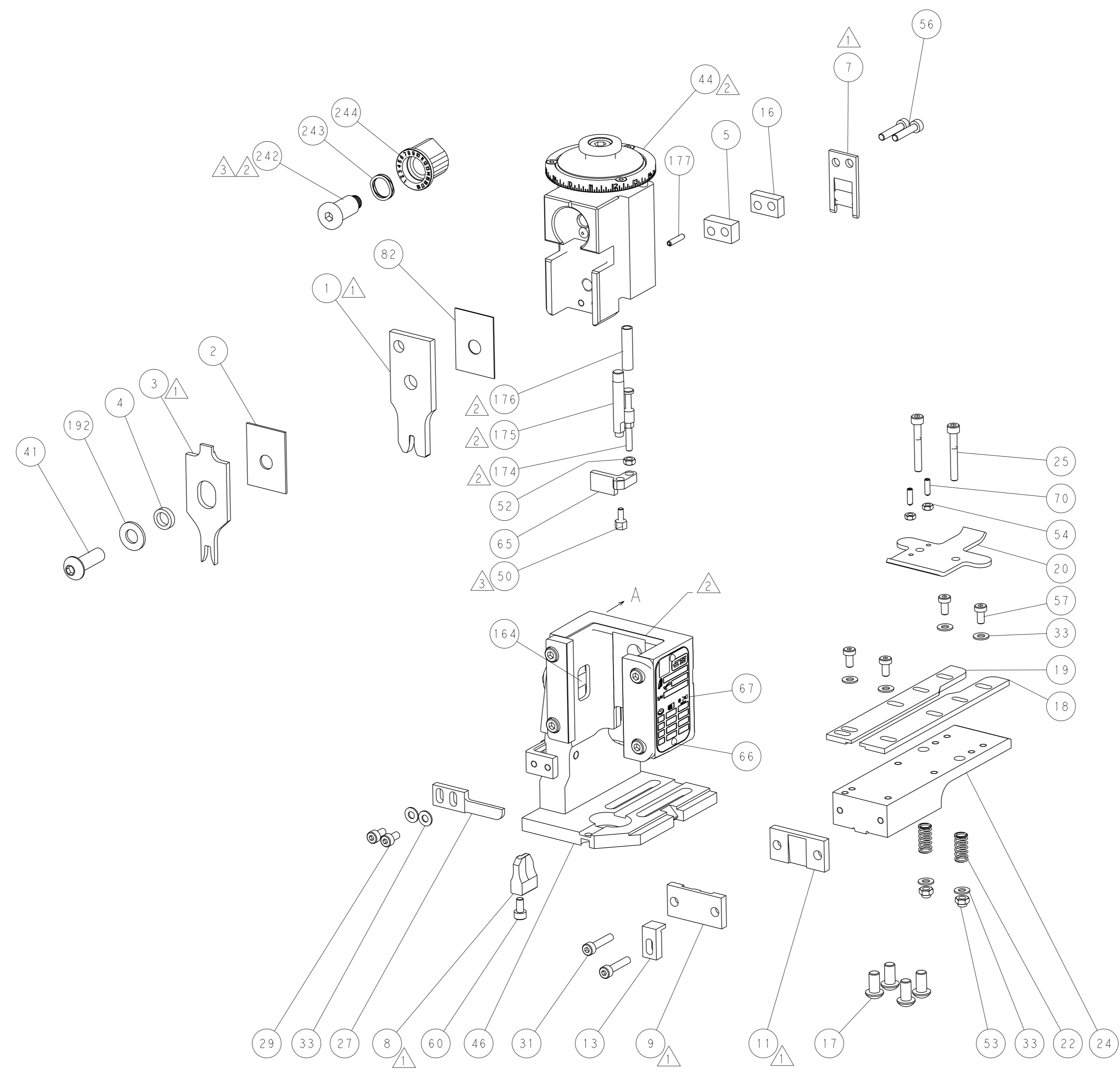
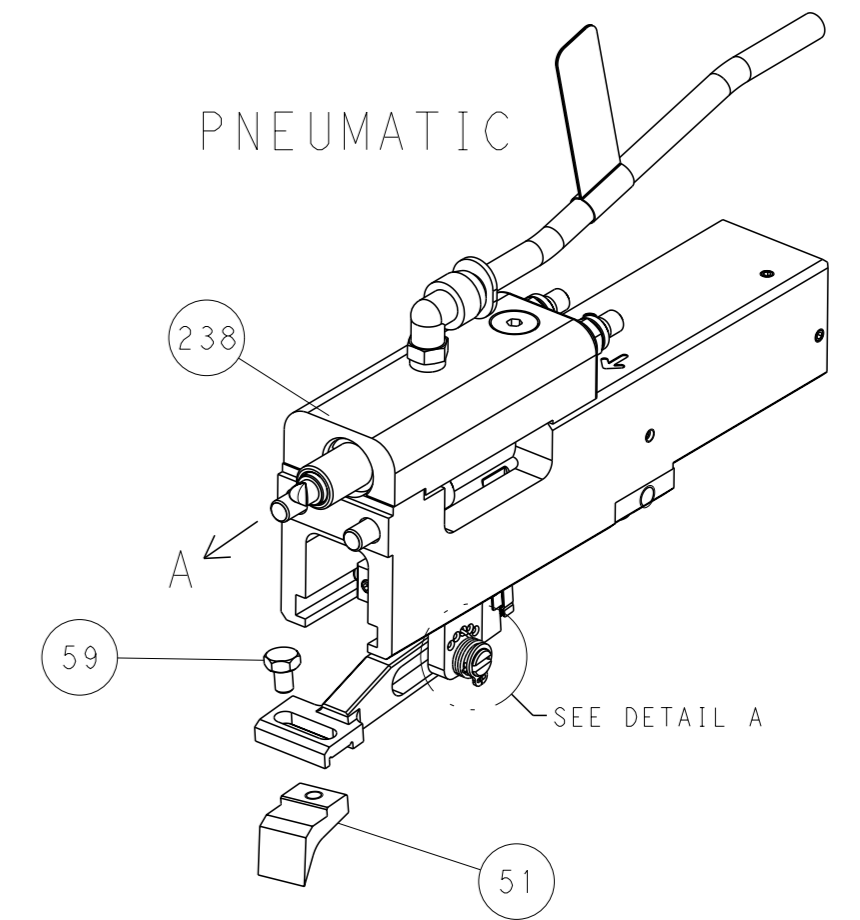

FEED SPRING SETTING POSITION

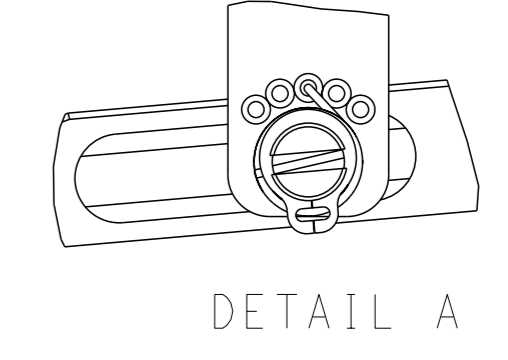

CAM POSITION

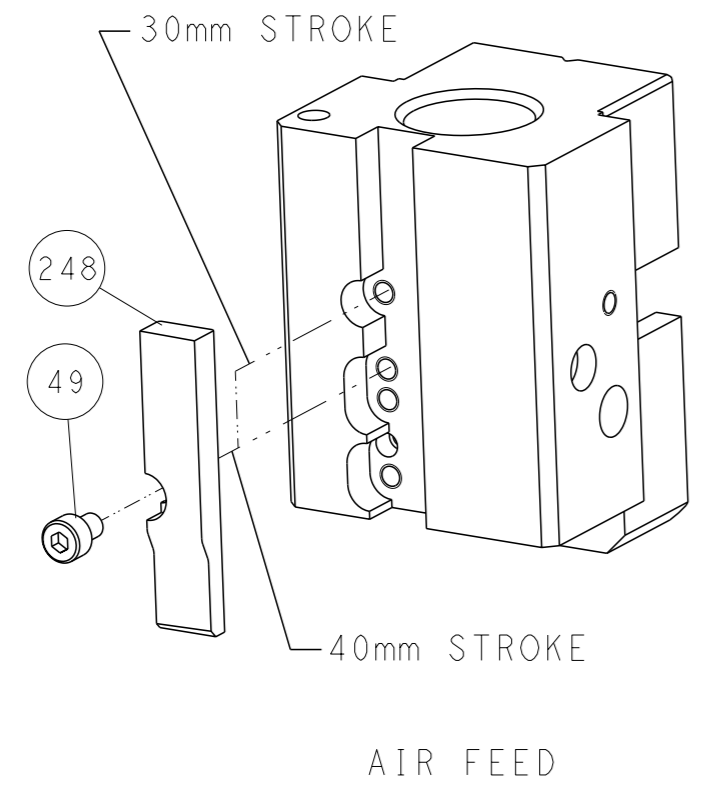

AIR FEED

ATLANTIC VERSION
 Shown on sheets 1 of 4 & 2 of 4
 (Pacific version shown on sheets 3 of 4 & 4 of 4)

<small>THIS DRAWING IS A CONTROLLED DOCUMENT FROM TYCO ELECTRONICS CORPORATION. IT IS SUBJECT TO CHANGE AND THE CONTROL AND REVISIONS ORGANIZATION SHOULD BE CONTACTED FOR THE LATEST REVISION.</small>		OWN: Y. YIN CHK: G. BAILEY APVD: S. YI	06FEB2012 06FEB2012 06FEB2012	TE Connectivity Harrisburg, PA 17105-3608
DIMENSIONS: mm 		TOLERANCES UNLESS OTHERWISE SPECIFIED: 0 PLC ± 1 PLC ± 2 PLC ± 3 PLC ± 4 PLC ± ANGLES FINISH *	NAME: Ocean End Feed Applicator SIZE: A1 CAGE CODE: 00779 DRAWING NO: C=2150046	RESTRICTED TO: - SCALE: 1:1 SHEET: 2 of 4 REV: J
MATERIAL: -		WEIGHT: -	Customer Accessible Production Drawing	

PART NUMBER	REVISION	DESCRIPTION	FEED TYPE
2-2150046-2	J	FINE CRIMP HEIGHT ADJUST	PNEUMATIC
7-2150046-7	B	CRIMP TOOLING KIT	-

PACIFIC VERSION TERMINATOR
 INTERFACE ADAPTER

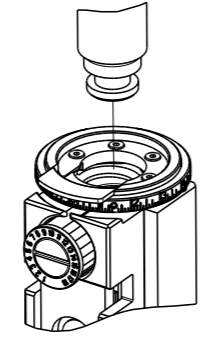

APPLICATOR DATA

CRIMP	SIZE	TYPE
WIRE	2.79 mm [.110]	F
INSUL	4.06 mm [.160]	F

APPLICATOR INSTRUCTIONS
 408-35043

TERMINAL DATA: TE TERMINAL TE CRIMP SPECIFICATION

TERMINAL NAME: .250 SERIES FASTIN-FASTON TAB

WIRE STRIP LENGTH	INSULATION DIAMETER RANGE
5.41-6.07 mm [.213-.239 IN]	Ø3.05-4.32 mm [.120-.170 IN]

TERMINAL APPLICATION SPECIFICATION (A)114-2025

TERMINALS APPLIED

TE TERMINAL	TE TERMINAL	TE TERMINAL	TE TERMINAL
(A) 42099-2	(A) 160450-5	(A) 160457-1	(A) 160740-1
(A) 42580-2	(A) 160452-1	(A) 160457-2	(A) 160740-2
(A) 160450-1	(A) 160452-2	(A) 160457-3	(A) 170151-1
(A) 160450-2		(A) 160459-1	(A) 170151-2
(A) 160450-3		(A) 160459-3	(A) 170151-3

TERMINAL DATA: TE TERMINAL TE CRIMP SPECIFICATION

TERMINAL NAME: .250 SERIES FASTIN-FASTON TAB

WIRE STRIP LENGTH	INSULATION DIAMETER RANGE
5.41-6.07 mm [.213-.239 IN]	Ø3.05-4.32 mm [.120-.170 IN]

TERMINAL APPLICATION SPECIFICATION (B)114-20021

TERMINALS APPLIED

TE TERMINAL	TE TERMINAL	TE TERMINAL	TE TERMINAL
(B) 42098-1	(B) 42460-5	(B) 280081-6	(B) 1-280081-2
(B) 42098-2	(B) 42460-6	(B) 280081-7	
(B) 42098-3	(B) 280081-1	(B) 280081-8	
(B) 42460-1	(B) 280081-2	(B) 280081-9	
(B) 42460-2	(B) 280081-3	(B) 1-280081-0	
(B) 42460-3	(B) 280081-4	(B) 1-280081-1	

WIRE SIZE	CRIMP HEIGHT mm [INCH]	CRIMP HEIGHT REFERENCE SETTING
14 AWG	1.93+/-0.05 [.076+/-0.002]	3.2
2.50mm2	1.91+/-0.05 [.075+/-0.002]	3.4
16 AWG	1.70+/-0.05 [.067+/-0.002]	5.7
1.50mm2	1.65+/-0.05 [.065+/-0.002]	6.2
18 AWG	1.55+/-0.05 [.061+/-0.002]	7.2
1.00mm2	1.52+/-0.05 [.060+/-0.002]	7.5

WIRE SIZE	CRIMP HEIGHT mm [INCH]	CRIMP HEIGHT REFERENCE SETTING
2.50mm2	1.91+/-0.05 [.075+/-0.002]	3.4
2x 0.75mm2	1.65+/-0.05 [.065+/-0.002]	6.0
1.50mm2	1.65+/-0.05 [.065+/-0.002]	6.0
1.00mm2	1.52+/-0.05 [.060+/-0.002]	6.7
0.75mm2	1.45+/-0.05 [.057+/-0.002]	8.4

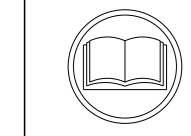

- RECOMMENDED SPARE PARTS
- REFER TO SUPPLIED INSTRUCTION SHEET FOR CLEANING, LUBRICATION AND STORAGE OF APPLICATOR.
- APPLY PART NUMBER 2-23419-6 LOCTITE TO THREADS OF ITEM 242. APPLY PART NUMBER 1-23419-5 LOCTITE TO THREADS OF ITEM 50.
- CRIMP HEIGHT REFERENCE SETTING WAS THE SETTING USED WHEN THE APPLICATOR WAS QUALIFIED AT THE FACTORY. ADJUSTMENT MAY BE NECESSARY WHEN RUNNING APPLICATOR IN THE FIELD.
- TERMINAL PITCH NOT COMPATIBLE WITH MECHANICAL FEED.
- UNLESS SPECIFIED OTHERWISE TORQUE VALUES SHALL BE USED PER DOCUMENT, 101-35000.

***WARNING**
 ON INSTALLATION, SET WIRE DISC TO CRIMP HEIGHT REFERENCE SETTING FOR LARGEST WIRE SIZE. CRIMP HEIGHT REFERENCE SETTINGS GREATER THAN THE VALUE SHOWN MAY CAUSE DAMAGE TO THE CRIMP TOOLING. REFER TO THE INSTRUCTION SHEET FOR PROPER SETUP AND ADJUSTMENTS.

PACIFIC VERSION
 Shown on sheets 3 of 4 & 4 of 4
 (Atlantic version shown on sheets 1 of 4 & 2 of 4)

LOC	DIST	REV	DATE	BY	APPV
A	66				

REV	DATE	DESCRIPTION	ITEM NO	
-	1	2119082-9	CAM, SNAIL, INSULATION ADJUSTMENT	244
-	1	2079764-1	WASHER, WAVE SPRING, CREST-TO-CREST	243
-	1	2119083-1	RETAINER, INSULATION DIAL	242
-	1	2844940-4	AIR FEED MODULE	238
-	1	1-18028-0	WASHER, FLAT, REG M8	192
-	4	2079383-9	SCR, BHSC, RoHS (M6 X 20)	186
-	1	6-993111-6	PIN, SLOTTED SPRING 3.0 X 14.0	177
-	1	8-22280-7	SPRING, COMPRESSION	176
-	1	1752353-2	GUIDE PIN,HOLDDOWN	175
-	1	1901680-2	GUIDE PIN,HOLDDOWN	174
-	REF	994970-2	COUNTER, MAGNETIC	164
-	1	2119641-2	FEED CAM, AIR FEED	152
-	1	2168083-8	SCR, SKT HD CAP, RoHS, M4 X 16	144
-	1	2119655-6	APPLICATOR BASIC ASSEMBLY, EF	141
-	1	1803518-1	RAM ASSEMBLY, EF PACIFIC	140
-	1	455888-5	SPACER, CRIMPER	82
-	1	1803607-4	DOCUMENTATION PACKAGE	71
-	2	2-18032-2	SCR, SET, FLT PNT, M3 X 10.0	70
-	1	2119740-1	TAG, IDENTIFICATION	67
-	2	2168078-1	SCREW, DRIVE, RH, RoHS, 2 x .188	66
-	1	1976052-1	HOLDDOWN, TERMINAL	65
-	1	5-18022-5	SCR, HEX HD CAP, M4 X 6.0	59
-	4	2168400-4	SHCS, LOW HEAD, RoHS, M4 X 8	57
-	2	2168083-9	SCR, SKT HD CAP, RoHS, M4 X 20	56
-	2	5018030-1	NUT, HEX, REG, RoHS, M3	54
-	2	986965-8	NUT, LOCK, HEX, TORQUE (M4)	53
-	1	1-5018030-0	NUT, HEX, REG, RoHS, M3.5	52
-	1	2063961-1	FEED FINGER	51
-	1	1752354-2	STANDOFF,HOLD-DOWN	50
-	1	18023-9	SCR, SKT HD CAP M4 X 6.0	49
-	1	1803602-1	SCR, BHSC, RoHS (M8 X 25)	41
-	8	1-18028-2	WASHER, FLAT, REG M4	33
-	2	2168083-9	SCR, SKT HD CAP, RoHS, M4 X 20	31
-	2	2168083-2	SCR, SKT HD CAP, RoHS, M4 X 8.0	29
-	1	240639-1	STRIPPER (MACHINING)	27
-	2	1-2168083-5	SCR, SKT HD CAP, RoHS, M4 X 30	25
-	1	1752371-5	PLATE, STRIP GUIDE	24
-	2	2-22281-3	SPRING, COMPRESSION	22
-	1	1803292-4	DRAG	20
-	1	1-1901696-9	STRIP GUIDE, REAR	19
-	1	1-1901695-9	STRIP GUIDE, FRONT	18
-	1	6-240641-5	SPACER	16
-	1	1752360-1	SPACER,HOLD-DOWN	13
-	1	240644-1	PLATE, REAR SHEAR	11
-	-	-	-	10
-	1	690482-4	PLATE, FRONT SHEAR	9
-	1	1333219-4	ANVIL, COMBINATION	8
-	1	1-690474-7	BLADE, SLUG	7
-	-	-	-	6
-	1	2-240641-7	SPACER	5
-	1	238011-2	BLOCK, CRIMPER SPACER	4
-	1	3-2119582-4	CRIMPER, INSULATION F PREMIUM	3
-	1	1-455888-0	SPACER, CRIMPER	2
-	1	456408-5	CRIMPER, WIRE PREMIUM	1
-	77-22	PART NO	DESCRIPTION	ITEM NO

DIMENSIONS: mm 	TOLERANCES UNLESS OTHERWISE SPECIFIED: 0 PLC ± 1 PLC ± 2 PLC ± 3 PLC ± 4 PLC ± ANGLES FINISH ±	DWG Y.YIN 06FEB2012 CHK G.BAILEY 06FEB2012 APVD S.YI 06FEB2012 NAME PRODUCT SPEC APPLICATION SPEC SIZE CASE CODE DRAWING NO A1 00779 C=2150046 RESTRICTED TO Customer Accessible Production Drawing SCALE 1:1 SHEET 3 of 4 REV J	TE Connectivity Harrisburg, PA 17105-3608 Ocean End Feed Applicator
-----------------------	--	---	--

LOC	DIST	REVISIONS			
A	66	REV	DATE	OWN	APVD
		-	SEE SHEET 1	-	-

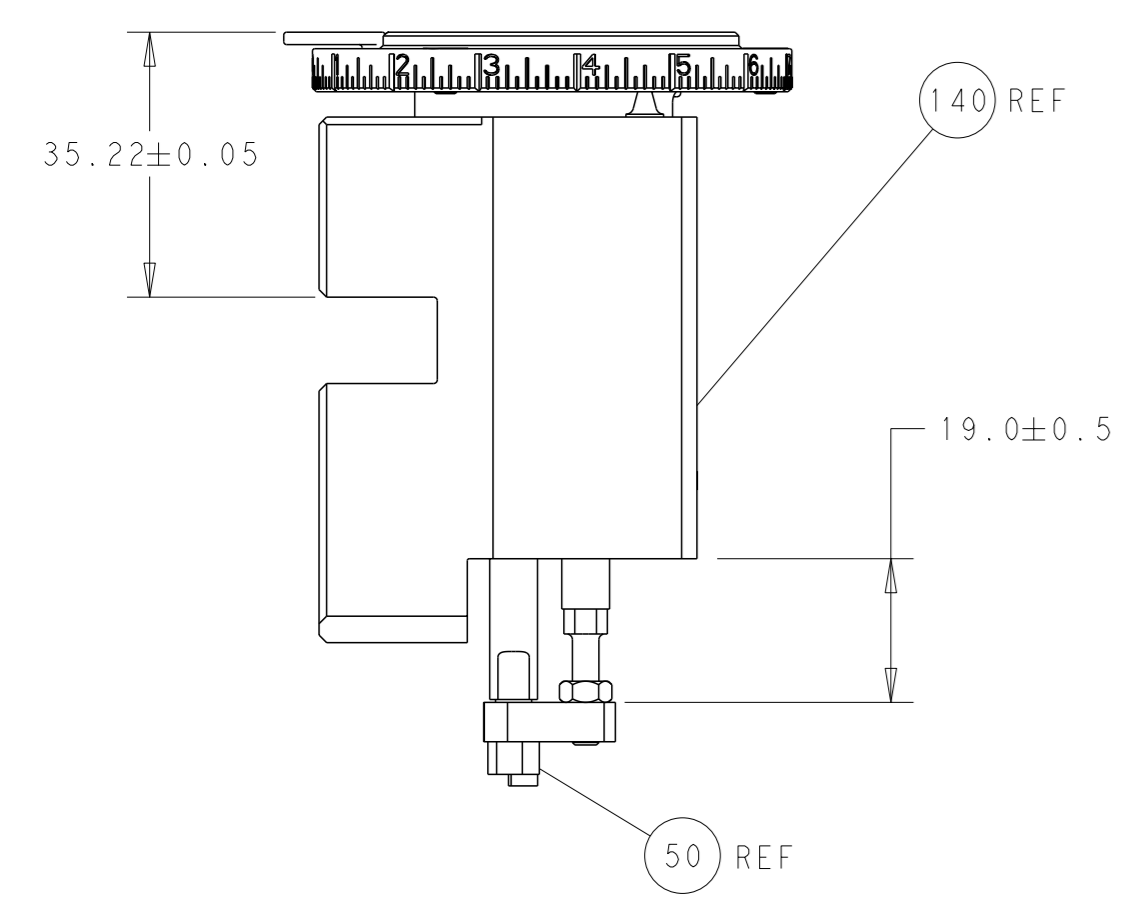

RAM AND HOLDDOWN SET-UP

FEED TYPE

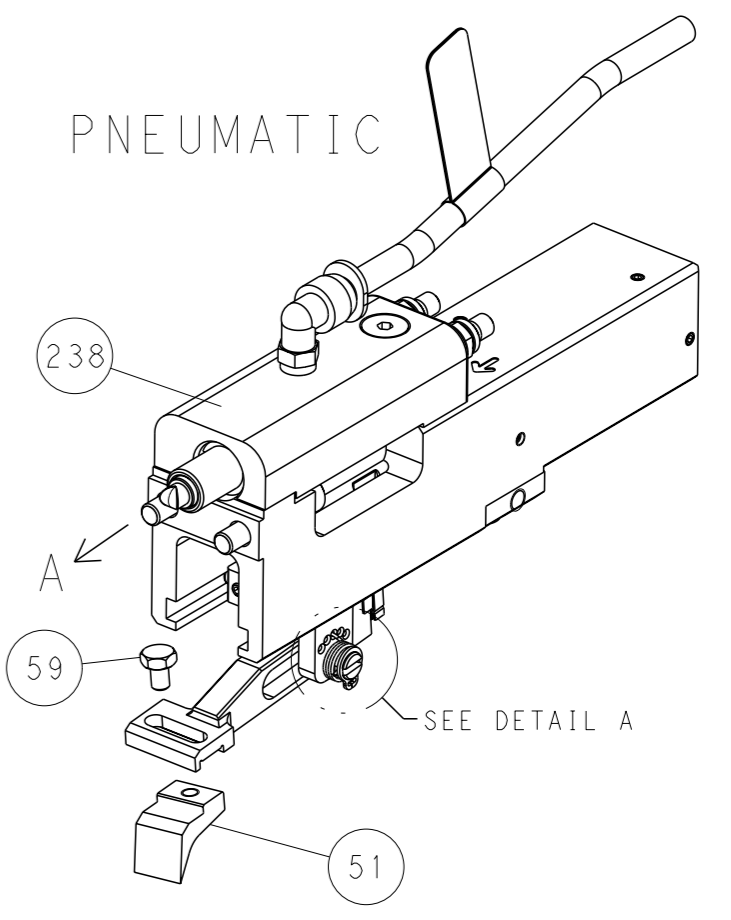

FEED SPRING SETTING POSITION

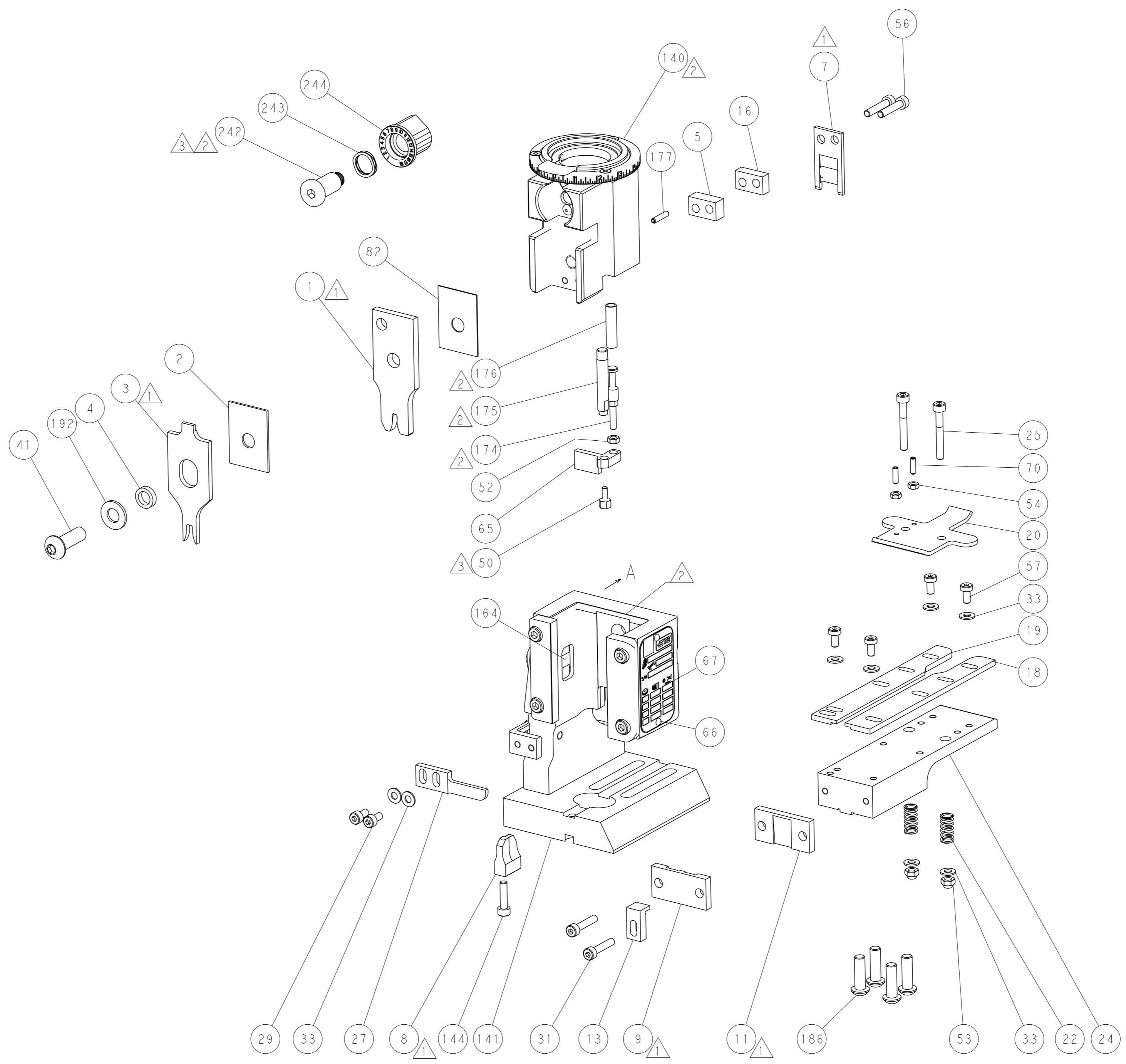
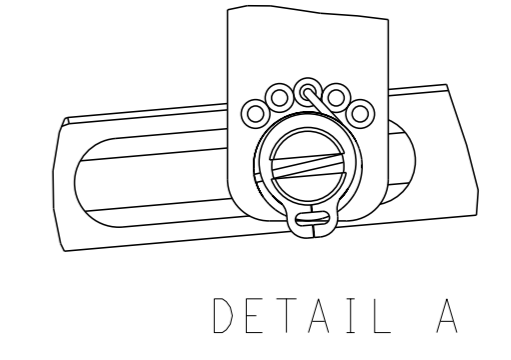

CAM POSITION

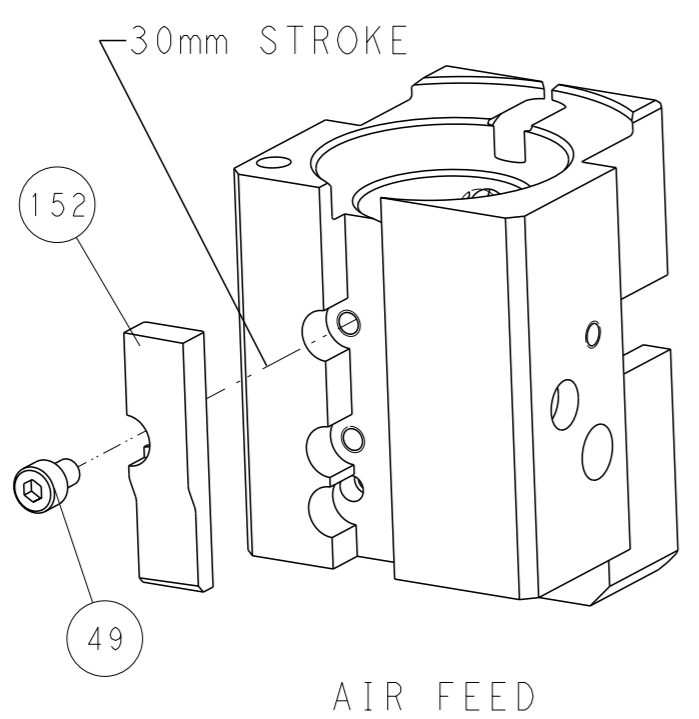

AIR FEED

PACIFIC VERSION
 Shown on sheets 3 of 4 & 4 of 4
 (Atlantic version shown on sheets 1 of 4 & 2 of 4)

<small>THIS DRAWING IS A CONTROLLED DOCUMENT FOR TYCO ELECTRONICS CORPORATION. IT IS SUBJECT TO CHANGE AND THE USER'S RESPONSIBILITY TO OBTAIN THE LATEST REVISION SHOULD BE CONTACTED FOR THE LATEST REVISION.</small>		OWN: Y. YIN CHK: G. BAILEY APVD: S. XI	06FEB2012 06FEB2012 06FEB2012	NAME: Ocean End Feed Applicator SIZE: A1 CAGE CODE: 00779 DRAWING NO: C=2150046	RESTRICTED TO:
DIMENSIONS: mm TOLERANCES UNLESS OTHERWISE SPECIFIED: 0 PLC ± 1 PLC ± 2 PLC ± 3 PLC ± 4 PLC ± ANGLES FINISH *	WEIGHT: - SCALE: 1:1	SHEET: 4 OF: 4 REV: J	Customer Accessible Production Drawing		