

REV.	DATE	DESCRIPTION	BY	C'K'D'
A	2001-09-14	CONVERSION REVISION 05	KN	
B	2005-10-22	105-0196	ALEX B	BKP
C	2006-07-04	106-0096	VIVEK	BKP
05	2001-05-31	BEC 9,3525	R.M.	

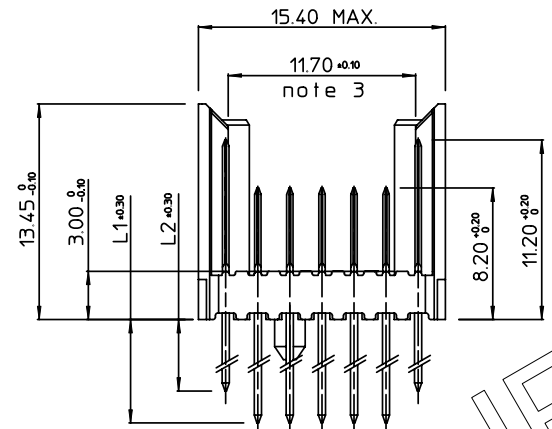
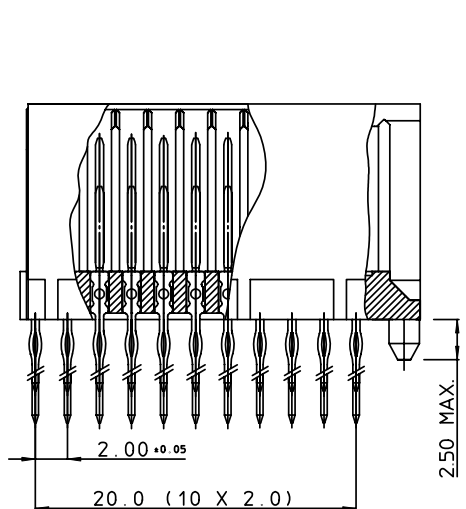

**PERFORMANCE CHARACTERISTICS**

CURRENT RATING : 1.5 A AT 20°C ( FULLY LOADED )  
 1 A AT 70°C ( FULLY LOADED )

RATED VOLTAGE : 500 V AC (CONT / CONT )

OPERATING TEMPERATURE : -55°C TO 125°C

CONTACT RESISTANCE : 20 mΩ MAX

INSERTION FORCE : 0.75 N MAX / CONT

EXTRACTION FORCE : 0.15 N MIN / CONT

INSULATION RESISTANCE : 10<sup>4</sup> MΩ MIN

CAT	NR.	L1 ±0.3	L2 ±0.3	DESCRIPTION
HM2P09PD5111----		3.7	3.7	SHORT PRESS-FIT
HM2P09PC5111----		4.5	4.5	SHORT PRESS-FIT
HM2P09PK5111----		13	4.5	REAR PLUG-UP: LEVEL 1
HM2P09PM5111----		14.5	4.5	REAR PLUG-UP: LEVEL 2
HM2P09PN5111----		16	4.5	REAR PLUG-UP: LEVEL 3
HM2P09PT5111----		13	4.5	WIRE WRAP

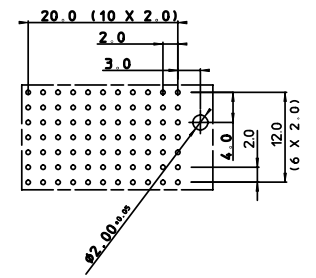
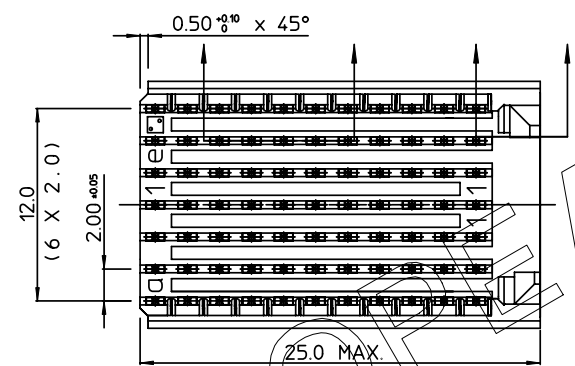

LAY-OUT  
P.C.B. - HOLE

**NOTES**

- \*HM2P09P#5111-----\*  
 PERFORMANCE LEVEL INDICATOR (REFER DWG No. BS,C ,201844,003)  
 LEAD FREE INDICATOR : LF=LEAD FREE (DIGIT 15&16)
- THIS PRODUCT IS CSA APPROVED.  
 THIS PRODUCT IS UL RECOGNIZED.
- MEASURED AT THE BOTTOM.
- FOR RECOMMENDED PTH DIMENSIONS REFER DRAWING : BS,A ,201572,001
- THE PRODUCT (LF) MEETS EUROPEAN UNION DIRECTIVES AND OTHER COUNTRY REGULATIONS AS DESCRIBED IN GS-22-008

MALE SIGNAL STRAIGHT PRESS-FIT-TO-BOARD CONNECTOR				
EXTENSION MODULE (WIDE BODY)				
1DEC ±0,2	<b>APPR.</b>	<b>DATE</b>	<b>SIGN.</b>	MILLIPACS 2 / TYPE C / SHIELDED
2DEC ±0,1	DRAFT	1994-05-17	W.Panis	<b>CAT. No.</b> HM2P09P#5111----
ANGLES ±1°	CHECKED			
WE RESERVE THE RIGHT TO CHANGE DIMENSIONS OR REQUIREMENTS WITHOUT PRIOR NOTICE.	PROD. MGR.			www.fciconnect.com
	PR. ENG. MGR.			
	PR. MGT. MGR.			
ALL DIMENSIONS IN MM	<b>REFERENCES</b>			SCALE 3/1

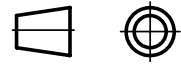

EUROPEAN PATENT

PROTECTED

THIS IS OUR EXCLUSIVE PROPERTY. IT IS NOT TO BE COPIED, REPRINTED OR DISCLOSED TO A THIRD PARTY, NOR USED FOR MANUFACTURING WITHOUT OUR WRITTEN CONSENT, AND HAS TO BE RETURNED TO US IN CASE OF NO USAGE

DIT IS ONZE EIGENDOM EN MAG NOCH NAGEMAKT, HERDRUKT, OVERGEMAAKT AAN DERDEN, NOCH VOOR FABRIKATIE GEBRUIKT WORDEN, ZONDER ONZE SCHRIFTELIJKE TOELATING. BIJ NIET GEBRUIK IS TERUGZENDING VERPLICHT.