

THIS DRAWING IS UNPUBLISHED. RELEASED FOR PUBLICATION
 © COPYRIGHT - By - ALL RIGHTS RESERVED.

REVISIONS					
P	LTR	DESCRIPTION	DATE	DWN	APVD
A3		REVISED PER ECR-16-003761	14MAR2016	LN	RS

- 1. CENTER CONTACT: CRIMPING TOOL M22520/2-01; POSITIONER M22520/2-20; SELECTOR SETTING PER TABLE
- 2. FERRULE: CRIMPING TOOL M22520/5-01; DIE NUMBER OR HEX SIZE PER TABLE
- 3. PRODUCT IS DESIGNED TO MEET PRODUCT SPECIFICATION 108-1574.
- 4. BRIGHT NICKEL PLATE.
- 5. COUPLING NUT MUST WITHSTAND 60 LB RETENTION FORCE. ALSO 15 IN-LB TORQUE WHEN MATED.
- 6. USE SELECTOR SETTING #7 FOR RG-142, 142A, 142B AND SELECTOR SETTING #6 FOR RG-400
- 7. INSTRUCTION SHEET: 408-4032

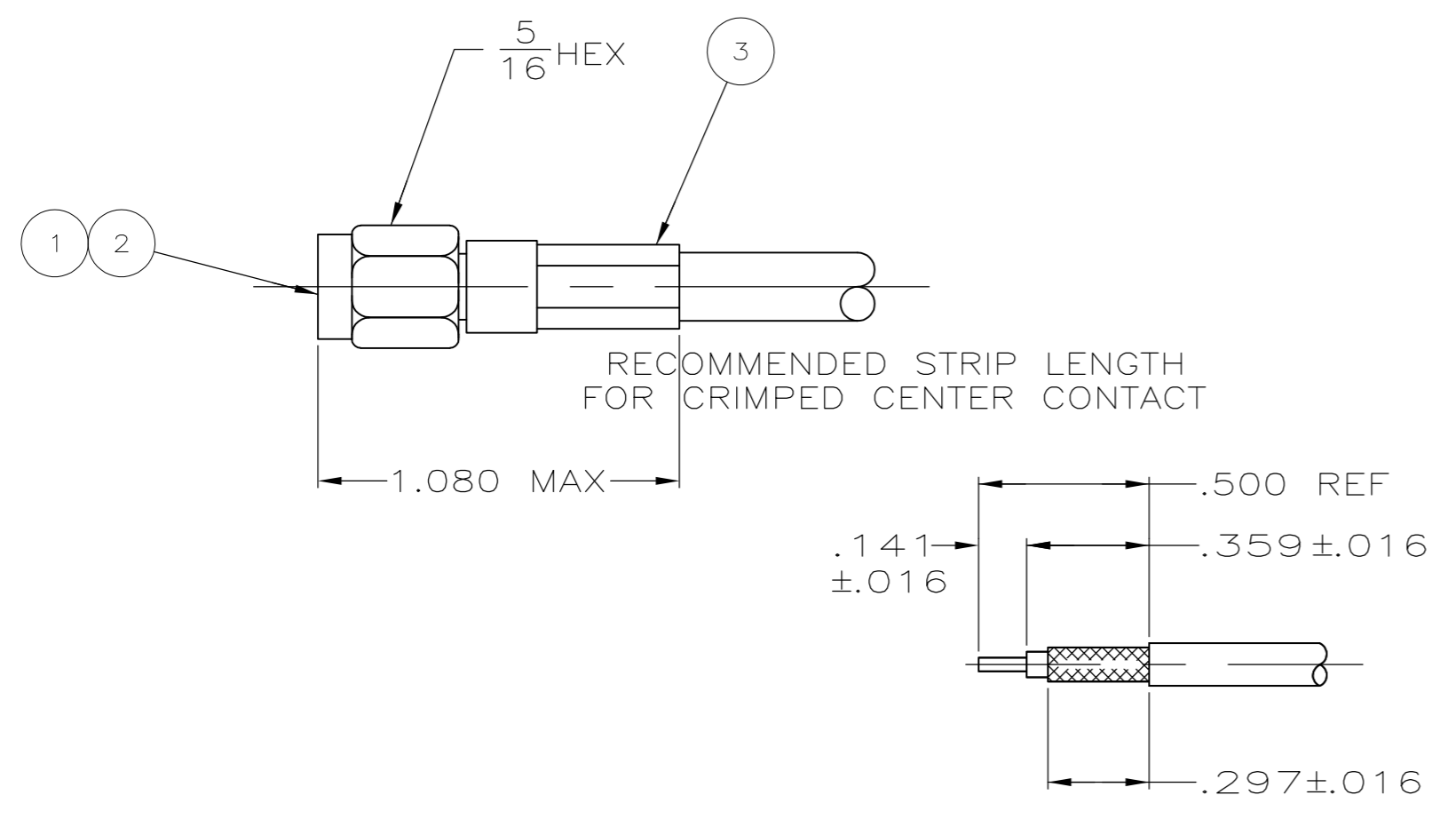

RG-55, 55 A, 55 B, 223	DIE M22520/5-11 A OR .213X.400 HEX	#7	4	BRASS	9-446556-3	443246-2	447844-1	1-5447647-0
RG-174, 188 A, 316	DIE M22520/5-35 B OR .128X.400 HEX	#4	4	BRASS	9-446556-1	447869-2	447844-4	5447647-3
RG-142, 142 A, 142 B, RG-400	DIE M22520/5-11 A OR .213X.400 HEX	6	4	BRASS	9-446556-0	443246-2	447844-1	5447647-2
RG-58, 58 A/U, 58 B/U, 58 C/U	DIE M22520/5-11 A OR .213X.400 HEX	#5	4	BRASS	9-446556-2	443246-2	447844-1	5447647-1
CABLE SIZE	2 DIE # OR HEX SIZE	1 SELECTOR SETTING	FINISH	MATERIAL	3 FERRULE QTY=1	2 CONTACT QTY=1	1 PLUG ASSY QTY=1	PART NUMBER
			SHELL					

THIS DRAWING IS A CONTROLLED DOCUMENT.		DWN L. VARELA - DOCK5 31JAN2005	TE TE Connectivity	
		CHK J. HAVENER 31JAN2005		
DIMENSIONS: INCHES		APVD D. CAMELIO 31JAN2005	NAME	
TOLERANCES UNLESS OTHERWISE SPECIFIED:		PRODUCT SPEC 108-1574	CONNECTOR, PLUG, SMA, HEX CRIMP, COMMERCIAL	
0 PLC ± -		APPLICATION SPEC	SIZE	CAGE CODE
1 PLC ± -			A2	00779
2 PLC ± -			DRAWING NO	
3 PLC ± -			C=5447647	
4 PLC ± -			RESTRICTED TO	
ANGLES ± -		WEIGHT -	-	
MATERIAL SEE TABLE		FINISH SEE TABLE	SCALE 1:1	SHEET 1 of 1
		CUSTOMER DRAWING	REV A3	