

PRODUCT NUMBER

73398-YXXXLF

RoHS COMPATIBLE, NOTE 6.
PACKAGING OPTIONS, NOTE 3.

PLATING

- 1= 0.76µm GOLD/GXT ON CONTACT AREA, 2µm TIN MIN ON TAILS
- 4= 2.0µm TIN MIN FULL PLATED
- 5= 0.25µm GOLD/GXT ON CONTACT AREA, 2µm TIN MIN ON TAILS ONLY AVAILABLE UPON REQUEST
- 8= 0.38µm GOLD/GXT ON CONTACT AREA, 2µm TIN MIN ON TAILS

1.27µm NICKEL MIN UNDERLAYER FOR ALL PLATING VERSIONS

STYLE	SIZE	DIM "A"	OMIT PINS
01	2x05	5.84	A5
02	2x03	5.84	B2
03	2x04	5.84	B1
04	2x11	8.38	A6
05	2x20	8.38	B10
06	2x05	8.38	A5
07	2x08	5.84	B7
08	2x04	5.84	B4
09	2x20	5.84	A11
10	2x07	5.84	A4-B7
11	2x13	5.84	A3-B1
12	2x12	5.84	A2
13	2x05	5.84	B5
14	2x05	5.84	B4
15	2x03	5.84	A2-B2
16	2x03	16.40	A2
17	2x05	5.84	A4
18	2x05	5.84	A2,3,4 B2,3,4
19	2x04	8.08	B2

NOTES:

1. HOUSING MAT'L : HIGH TEMPERATURE THERMOPLASTIC. UL94V-0 COLOR: BLACK

2. PIN MATERIAL : PHOSPHOR BRONZE

3 - PACKAGING OPTIONS:

- = POLY BAGS
- B = TUBE + CAP / ONLY AVAILABLE UPON REQUEST
- A = TAPE & REEL WITH CAP, AS AVAILABLE
- TR = CUSTOM TAPE & REEL WITH CAP, ONLY FOR PIN STYLE 01 PRODUCT 180° ROTATED VERSUS PACKAGING "A"

4. 9N MIN RETENTION IN EITHER DIRECTION

5. TO DETERMINE DIMENSIONS :
N = NUMBER OF POSITIONS PER ROW
EXAMPLE : 8 POS N x 2.54 = 20.32mm

6. RoHS COMPATIBLE PRODUCT SPECIFICATIONS

a - PLATING:

- "LF" MEANS THE PRODUCT IS LEAD-FREE, 2µm MINIMUM MATTE TIN OVER 1.27µm MINIMUM NICKEL UNDERPLATE.

b - MANUFACTURING PROCESS COMPATIBILITY

- THE HOUSING WILL WITHSTAND EXPOSURE TO 260°C PEAK TEMPERATURE FOR 30 SECONDES IN A CONVECTION, INFRA-RED OR VAPOR PHASE REFLOW OVEN.

c - LABELING:

- MEETS PACKAGING SPECS AS PER GS-14-920

d - LEGAL STATEMENT: SEE GS-47-0004

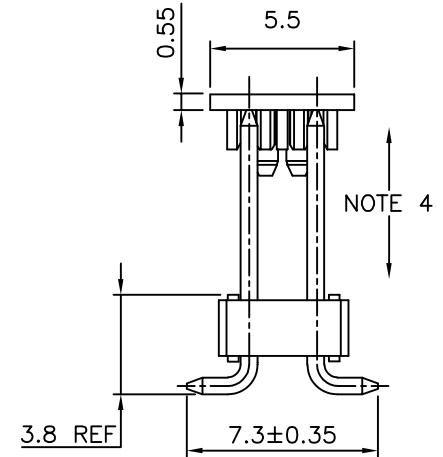
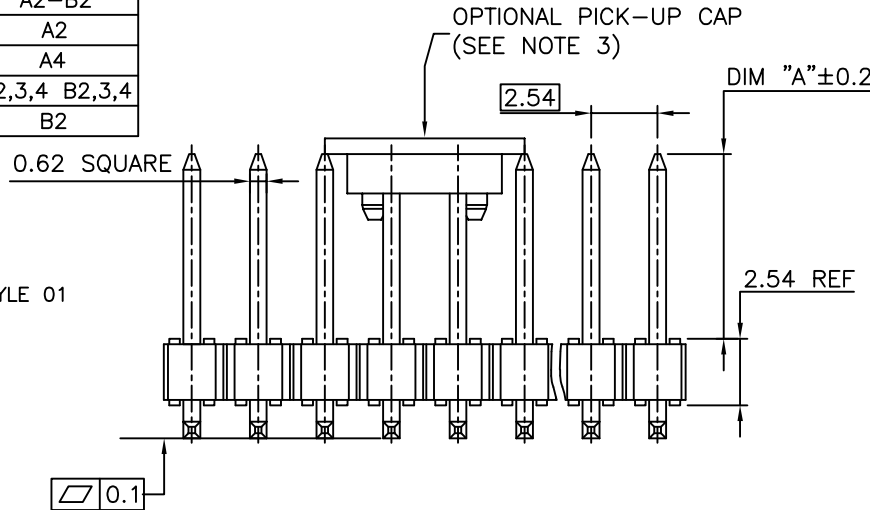
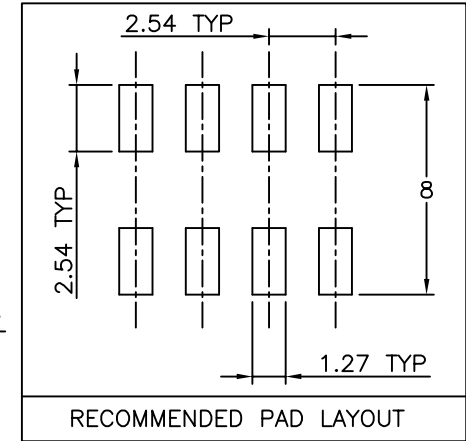
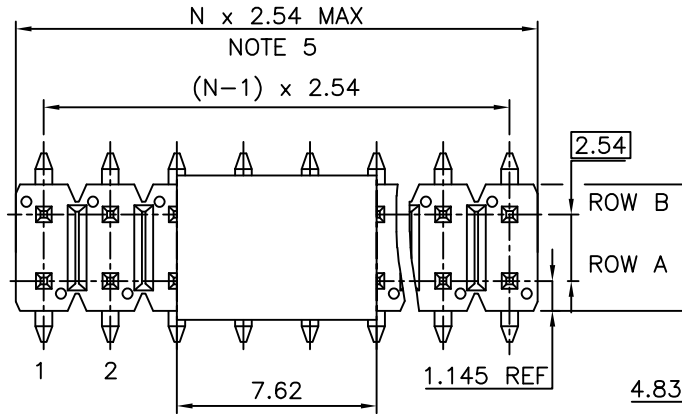

mat'l. code		surface		tolerance		projection		product family	
		ISO 1302		ISO 406 ISO 1101		mm		HEADER	
ltr		ecn no		dr		date		title	
Y		F-47086		DDE		23.01.20		HEADER DR	
AA		F-47114		DDE		23.01.25		DUPLX SMT POLARIZED	
U		F-26753		DDE		17.04.20		dwg no	
V		F-28256		LMU		17.10.25		sheet 1 of 1	
W		F-31154		DDE		18.09.04		size	
X		F-46844		DDE		22.12.21		A3	
sheet		revision		appd		JMC		type	
index		sheet						CUSTOMER Drawing	