

PANEL CUT OUT

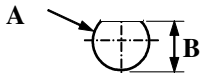

inches		
	Maxi	mini
A	.509	.505
B	.475	.471

REVISIONS			
REV.	DESCRIPTION	DATE	APPROVED
A	INITIAL RELEASE	05/14/18	D.N.

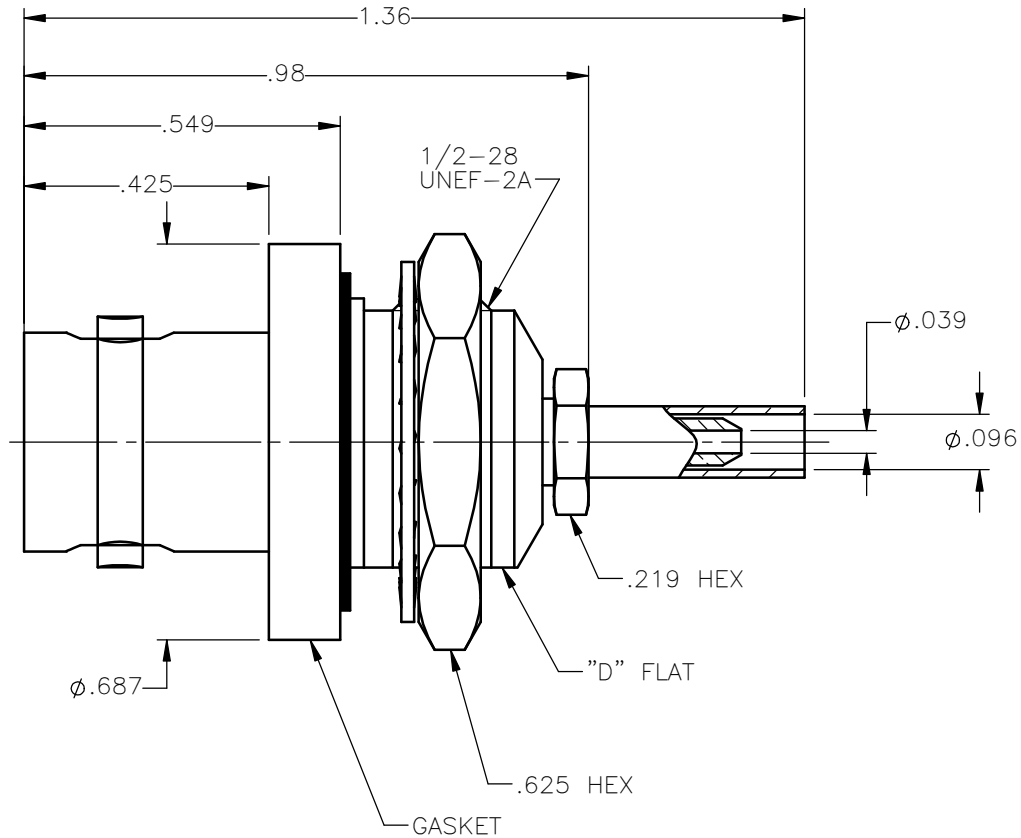

NOTES:

MATERIALS:

- CONTACT = BERYLLIUM COPPER PER ASTM B196, ALLOY C17300, TEMPER TD04.
- INSULATORS = VIRGIN WHITE TEFLON PER ASTM D1710, GRADE 1, TYPE I, CLASS "B".
- CRIMP SLEEVE = SEAMLESS LOWLEAD BRASS TUBE, ALLOY 330, SOFT ANNEAL TEMPER, .025/.060 GRAIN SIZE OR SEAMLESS COPPER TUBE PER ASTM B75, TYPE C12000, TEMPER: LIGHT ANNEAL O50 EXCEPT YIELD STRENGTH.
- GASKET = SILICONE RUBBER 45-55 DUROMETER, DOW CORNING SILASTIC 250.
- ALL OTHER METAL PARTS = BRASS PER ASTM B16, ALLOY C36000, TEMPER H02.

FINISHES:

- CONTACT & WIRE ADAPTER = GOLD PLATE PER ASTM B488-01, TYPE II, 50 μ in MIN, GRADE C, OVER 100 TO 200 μ in STRESS FREE SULFAMATE NICKEL PER QQ-N-290.
- ALL OTHER METAL PARTS = NICKEL PLATE PER QQ-N-290, 50 μ in MIN, GRADE G, EXCEPT 100 TO 200 μ in THICK OVER 50 TO 100 μ in THICK COPPER PER MIL-C-14550.

UNLESS OTHERWISE SPECIFIED DIMENSIONS ARE IN INCHES TOLERANCES ON

DWN:	DATE
D.N.	05/14/18
CHKD:	DATE
C.E.	05/14/18
APVD:	DATE
J.M.	05/14/18



Property of Radiall
This document cannot be reproduced or communicated to a third party without prior written permission of RADIALL.



BNC STRAIGHT BULKHEAD JACK
FRONT MOUNT CRIMP TYPE
FOR RG-178 & SIMILAR CABLES

REFERENCE:

ORIGINATED: D.N.
DATE: 05/14/18

MATERIALS & FINISHES:
SEE NOTES

SIZE	FSCM NO.	DWG NO.	REV
A	19505	6502-7071-002	A
SCALE	THIRD ANGLE PROJECTION		SHEET 1 OF 1
3:1			

6502-7071-002