

DSCT32

Analog Current Input Transmitters



Description

Each DSCT32 current input transmitter provides a single channel of analog input which is filtered, isolated, amplified, and converted to a process current output (Figure 1). Signal filtering is accomplished with a five-pole filter, which provides 80dB per decade of normal-mode rejection above 100Hz. An anti-aliasing pole is located on the field side of the isolation barrier, and the other four are on the process loop side. After the initial field-side filtering, the input signal is chopped by a proprietary chopper circuit. Isolation is provided by transformer coupling, again using a proprietary technique to suppress transmission of common mode spikes or surges.

Special input and output circuits on the DSCT32 transmitters provide protection against accidental connection of power-line voltages up to 240VAC and against transient events as defined by ANSI/IEEE C37.90.1. Signal and loop power lines are secured to the module using screw terminals, which are in pluggable terminal blocks for ease of system assembly and reconfiguration.

The modules have excellent stability over time and do not require recalibration, however, zero and span settings are adjustable up to ±10% to accommodate situations where fine-tuning is desired. The adjustments are made using potentiometers located under the front panel label and are non-interactive for ease of use.

Features

- Accepts Milliamp Level Signals
- Process Current Output
- 1500Vrms Transformer Isolation
- ANSI/IEEE C37.90.1 Transient Protection
- Input and Output Protected to 240VAC Continuous
- Up to 60V Loop Voltage
- 105dB CMR
- ±0.03% Accuracy
- ±0.01% Linearity
- Easily Mounts on Standard DIN Rail
- CSA C/US Certified
- CE Compliant

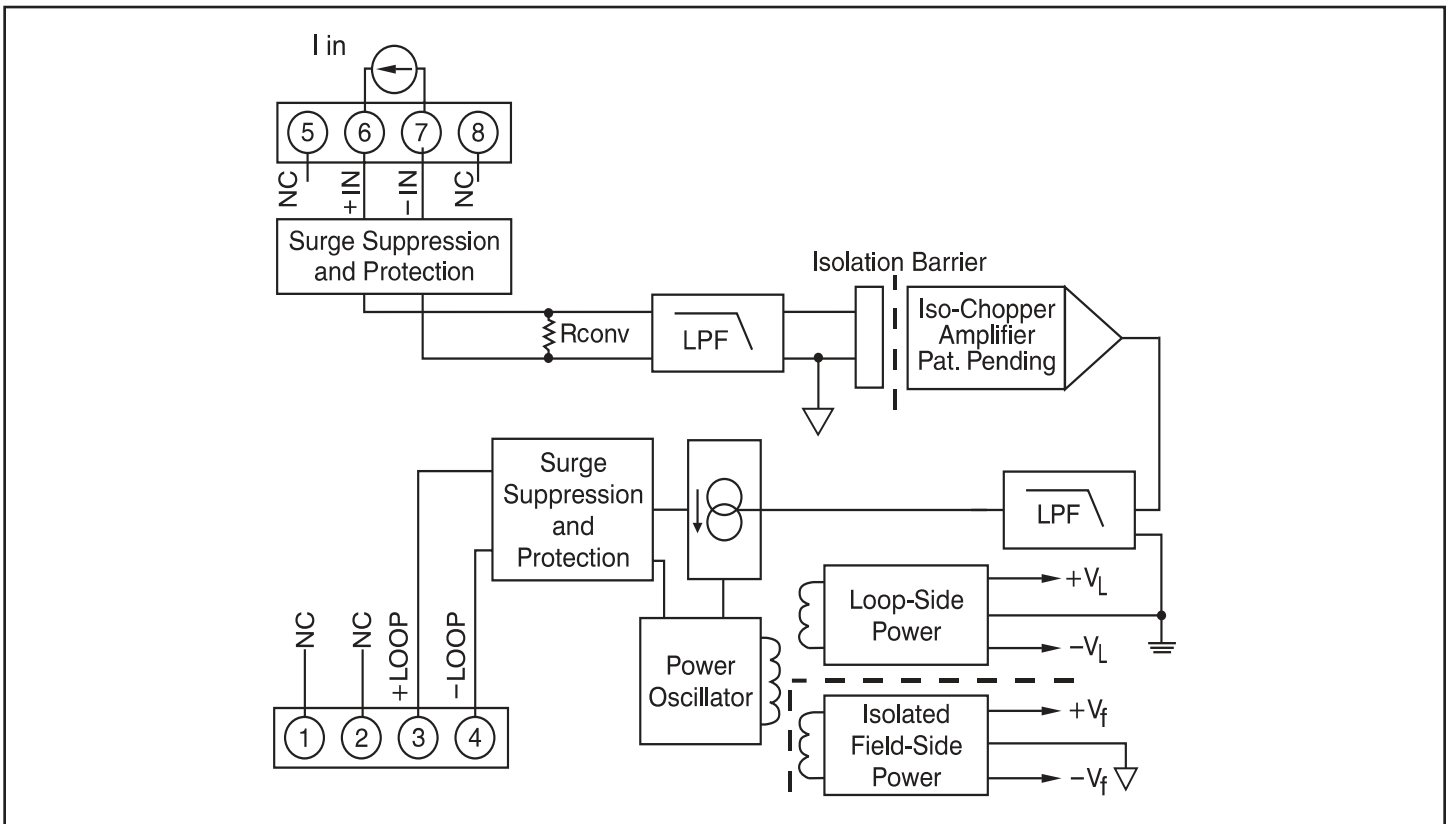

Figure 1: DSCT32 Block Diagram

Specifications Typical* at $T_A = +25^\circ\text{C}$ and +24VDC loop voltage

Module	DSCT32
Input Range	0-20mA or 4-20mA
Current Conversion Resistor	50.00 Ω
Input Protection	
Continuous	240Vrms max
Transient	ANSI/IEEE C37.90.1
CMV, Input to Output	
Continuous	1500Vrms max
Transient	ANSI/IEEE C37.90.1
CMR (50Hz or 60Hz)	105dB
NMR (-3dB at 100Hz)	80dB/decade Above 100Hz
Adjustability	$\pm 10\%$ Zero and Span
Accuracy ⁽¹⁾	$\pm 0.03\%$
Conformity	$\pm 0.01\%$
Stability	
Offset	$\pm 30\text{ppm}/^\circ\text{C}$
Gain	$\pm 90\text{ppm}/^\circ\text{C}$
Noise	
Output, 100kHz	3 μArms
Bandwidth, -3dB	100Hz
Response Time, 90% Span	5ms
Output Range	4mA to 20mA
Output Limits	
Under-range	2.8mA
Over-range	29mA
Output Protection	
Reverse Polarity	Continuous
Over-voltage	240Vrms Continuous
Transient	ANSI/IEEE C37.90.1
Loop Supply Voltage	10.8V to 60V
Loop Supply Sensitivity	$\pm 0.0005\%$ V
Turn-On Delay	400ms
Mechanical Dimensions (h)(w)(d)	2.95" x 0.89" x 4.13" (75mm x 22.5mm x 105mm)
Mounting	DIN EN 50022 -35x7.5 or -35x15 rail
Environmental	
Operating Temperature	-40°C to +80°C
Storage Temperature	-40°C to +80°C
Relative Humidity	0 to 95% Noncondensing
Emissions, EN61000-6-4	ISM, Group 1
Radiated, Conducted	Class A
Immunity EN61000-6-2	ISM, Group 1
RF	Performance A $\pm 0.5\%$ Span Error
ESD, EFT	Performance B

NOTES:

*Contact factory or your local Dataforth sales office for maximum values.

(1) Includes linearity, hysteresis and repeatability.

Ordering Information

Model	Input Range
DSCT32-01	4-20mA
DSCT32-02	0-20mA