

THIS DRAWING IS UNPUBLISHED. RELEASED FOR PUBLICATION 2009 MATED WITH: PASSEND ZU: -  
 © COPYRIGHT 2009 BY TYCO ELECTRONICS CORPORATION. ALL RIGHTS RESERVED.

LOC	DIST	REVISIONS			
P	LTR	DESCRIPTION	DATE	DWN	APVD
A1	-				
	A4	DRAWING STATUS CHANGED TO ACTIVE	11NOV2005	Abr	Goep
	A5	NOTE 1 ADDED, DIMENSION ADDED	19NOV2008	Haas	Goep
	A6	NEW PRDE DRAWING ECR-10-007842	12APR2010	Fru.	Goe

SECTION E-E  
Schnitt E-E

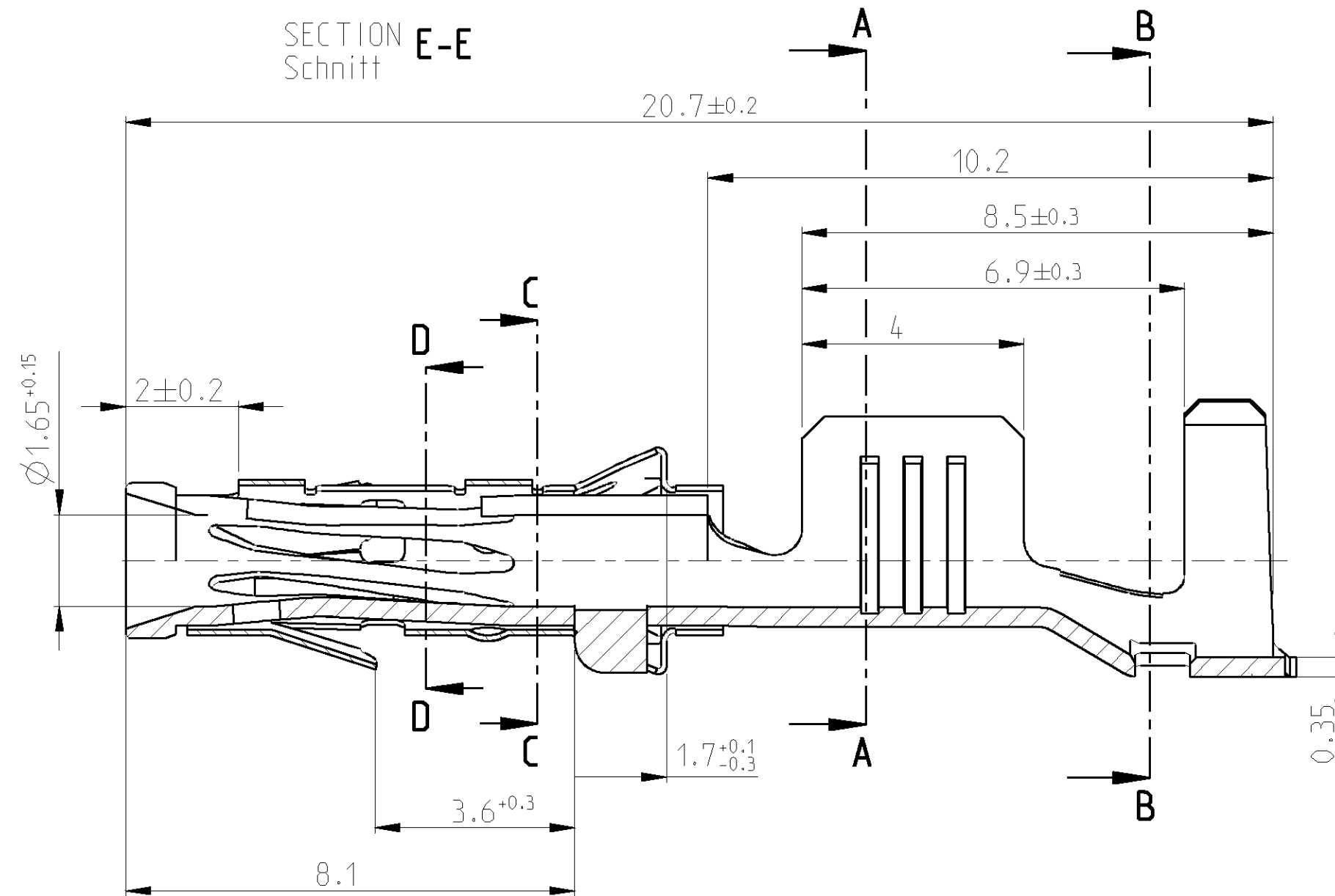

SECTION D-D  
Schnitt D-D

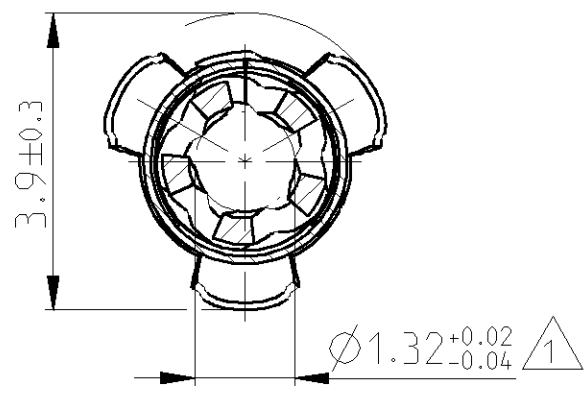

SECTION C-C  
Schnitt C-C

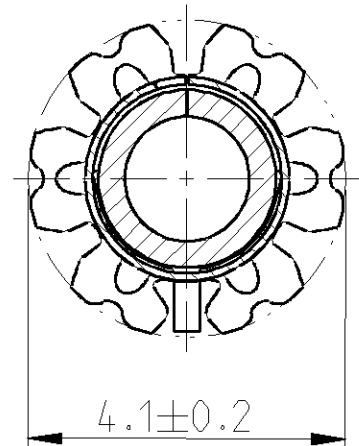

SECTION A-A  
Schnitt A-A

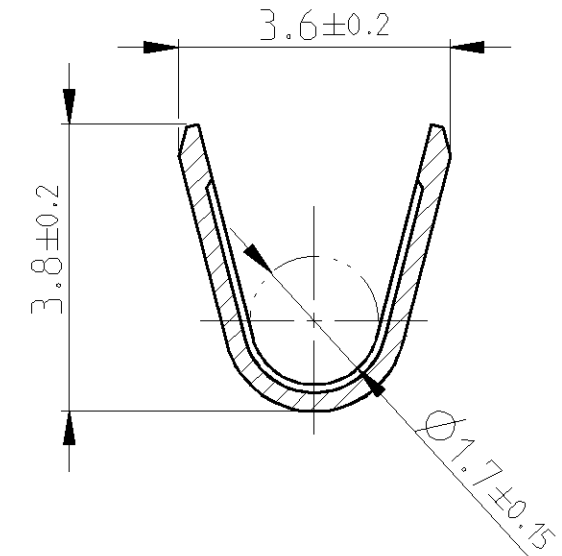

SECTION B-B  
Schnitt B-B

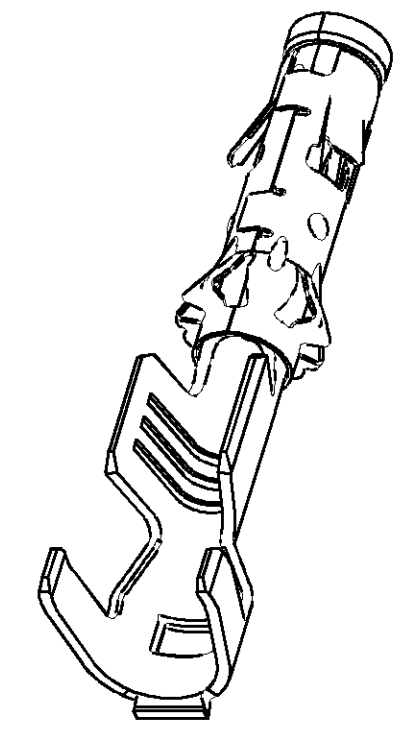
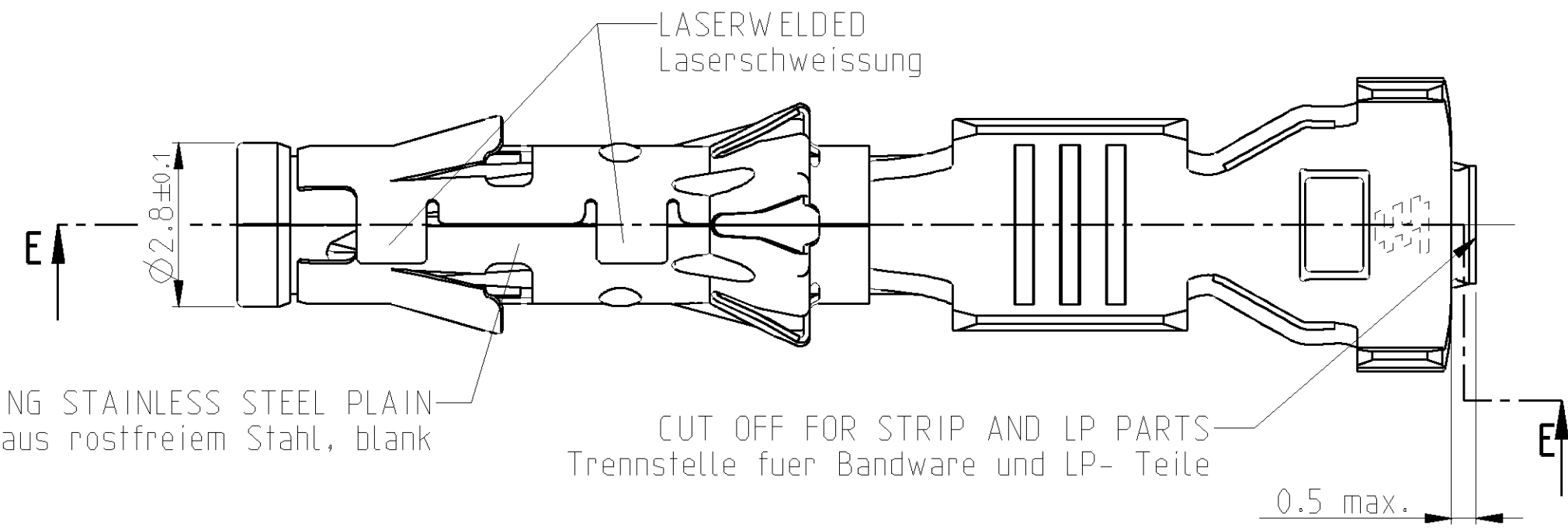
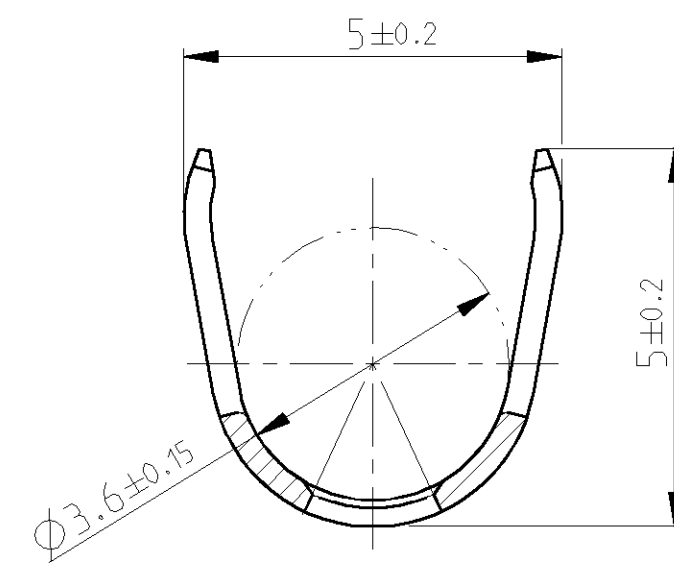

REMARKS  
Bemerkungen

⚠ FOR EVALUATING THE GAP SIZE, THE EXTRACTION FORCE OF MIN. 7N TESTED WITH TEST PIN 1703285-1, HAS PRIORITY. MEASURE AT A RATE OF 25mm/min. PRIOR TO EACH MEASUREMENT THE TESTPIN HAS TO BE CLEANED WITH AN ALCOHOL WIPE. THE MEASUREMENT CAN ONLY BE DONE AFTER THE COMPLETE DRYING OF THE SURFACE. Zur Beurteilung des Oeffnungsmasses ist die Ziehkraft min. 7N gepueft mit Pruefstift 1703285-1, ausschlaggebend. Pruefgeschwindigkeit 25MM/min. Der Testpin muss vor jedem Messen mit einem Tuch und Alkohol gereinigt werden. Die Buchse muss vor jeder Messung in Testbenzin gereinigt werden. Die Messung darf erst nach vollstaendiger Abtrocknung der Oberflaeche durchgefuehrt werden.

WIRE RANGE >1.0-2.5 mm <sup>2</sup>	-	-	-	-	-
INS. RANGE Ø3.4 mm FLR	1-1719188-0	A	-	CuNi18Zn20	PLAIN/blank
	AMP PART NO	REV.	PCS.	MATERIAL	SURFACE COLOR

DIMENSIONS: mm		TOLERANCES UNLESS OTHERWISE SPECIFIED: 0 PLC ±- 1 PLC ±- ±0.15 2 PLC ±- 3 PLC ±- 4 PLC ±- ANGLES ±- FINISH		DWN Abraham.G. 04AUG2005	Tyco Electronics Tyco Electronics AMP GmbH 64625 Bensheim (Germany)	
MATERIAL		PRODUCT SPEC		CHK Brunner.M. 05AUG2005	NAME DIA. 1.5mm CONTACT SOCKET Ø1.5mm Kontaktbuchse	
		APPLICATION SPEC 114-18040		APVD Bleicher.M. 05AUG2005	SIZE CAGE CODE DRAWING NO RESTRICTED TO	
		WEIGHT 0.4g		A2 00779 C-1719188		
		CUSTOMER DRAWING /KUNDENZEICHNUNG		SCALE 10:1 SHEET 1 OF 1 REV A6		