

ATLANTIC VERSION TERMINATOR
 INTERFACE ADAPTER



PART NUMBER	REVISION	DESCRIPTION	FEED TYPE
2151477-1	L	FINE CRIMP HEIGHT ADJUST	MECHANICAL
2151477-2	L	FINE CRIMP HEIGHT ADJUST	PNEUMATIC
3-2151477-2	L	FINE CRIMP HEIGHT ADJUST DOUBLE ACTING PNEUMATIC WITH SENSORS	
5-2151477-1	L	SEAL STRIPPER CRIMPER TERMINATING UNIT	MECHANICAL
5-2151477-2	L	SEAL STRIPPER CRIMPER TERMINATING UNIT	PNEUMATIC
7-2151477-1	L	MECHANICAL AND CRIMP TOOLING KIT	MECHANICAL
7-2151477-2	L	PNEUMATIC AND CRIMP TOOLING KIT	PNEUMATIC
7-2151477-7	A	CRIMP TOOLING KIT	-

APPLICATOR DATA		
CRIMP	SIZE	TYPE
WIRE	1.40 mm [.055]	F
INSUL	3.18 mm [.125]	O
APPLICATOR INSTRUCTIONS 408-35042		

TERMINAL DATA: TE TERMINAL		TE CRIMP SPECIFICATION	
TERMINAL NAME: TAB CONTACT 1.2MM			
WIRE STRIP LENGTH		INSULATION DIAMETER RANGE	
3.30-3.90 mm [.130-.154 IN]		\varnothing 5	
TERMINAL APPLICATION SPECIFICATION	114-18464		
TERMINALS APPLIED 9			
TE TERMINAL	TE TERMINAL	TE SEAL	TE SEAL
1718760-1	1718760-2	967067-1	963142-2
1718760-3			

TERMINAL DATA: TE TERMINAL		TE CRIMP SPECIFICATION	
TERMINAL NAME: TAB CONTACT 1.2MM			
WIRE STRIP LENGTH		INSULATION DIAMETER RANGE	
3.30-3.90 mm [.130-.154 IN]		\varnothing 5	
TERMINAL APPLICATION SPECIFICATION	114-18464		
TERMINALS APPLIED 9			
TE TERMINAL	TE TERMINAL	TE SEAL	TE SEAL
2141116-1	2208328-3	967067-1	963142-2
2141116-3			

TERMINAL DATA: TE TERMINAL		TE CRIMP SPECIFICATION	
TERMINAL NAME: TAB CONTACT 1.2MM			
WIRE STRIP LENGTH		INSULATION DIAMETER RANGE	
3.30-3.90 mm [.130-.154 IN]		\varnothing 5	
TERMINAL APPLICATION SPECIFICATION			
TERMINALS APPLIED 9			
TE TERMINAL	TE TERMINAL	TE TERMINAL	TE SEAL
1718760-1	1718760-2	1718760-3	967067-1

WIRE SIZE	CRIMP HEIGHT mm [INCH]	CRIMP HEIGHT REFERENCE SETTING
0.75mm2	1.05+/-0.03 [.041+/- .001]	5.9
20 AWG OR 0.50mm2	0.93+/-0.03 [.037+/- .001]	7.2

WIRE SIZE	CRIMP HEIGHT mm [INCH]	CRIMP HEIGHT REFERENCE SETTING
0.75mm2	0.98+/-0.03 [.039+/- .001]	6.8
20 AWG OR 0.50mm2	0.93+/-0.03 [.037+/- .001]	7.2

WIRE SIZE	CRIMP HEIGHT mm [INCH]	CRIMP HEIGHT REFERENCE SETTING
20 AWG (19 / 0.203 mm)	0.99+/-0.03 [.039+/- .001]	6.7
0.61mm2	0.99+/-0.03 [.039+/- .001]	6.7

- 1 RECOMMENDED SPARE PARTS
- 2 REFER TO SUPPLIED INSTRUCTION SHEET FOR CLEANING, LUBRICATION AND STORAGE OF APPLICATOR.
- 3 APPLY PART NUMBER 1-23419-5 LOCTITE TO THREADS OF ITEM 180. APPLY PART NUMBER 2-23419-6 LOCTITE TO THREADS OF ITEM 242.
- 4 CRIMP HEIGHT REFERENCE SETTING WAS THE SETTING USED WHEN THE APPLICATOR WAS QUALIFIED AT THE FACTORY. ADJUSTMENT MAY BE NECESSARY WHEN RUNNING APPLICATOR IN THE FIELD.
- 5 THIS APPLICATOR APPLIES TERMINAL WITH A SEAL.

SEAL P/N	INS. \varnothing
967067-1	1.4-2.1mm
963142-2	0.9-1.3mm
1718760-3	1.4-1.9mm
- 6 APPLY TORO-SEAL IN ALLEN SOCKET TO FILL HOLE AFTER FLAT HD HAS BEEN ADJUSTED TO CORRECT HEIGHT AT QUALIFICATION. APPLY #1-23419-5 LOC-TITE TO THREADS.
- 7 THIS CRIMP PARAMETER IS PROVIDED TO MEET A CUSTOM AND UNIQUE CUSTOMER REQUIREMENT. IT HAS BEEN EVALUATED AND IS CONDITIONALLY SPECIFIED BY TE CONNECTIVITY. THIS CUSTOMIZED CRIMP PARAMETER IS NOT LISTED AS AN APPROVED APPLICATION WITHIN A TE CONNECTIVITY APPLICATION SPECIFICATION; HOWEVER, IT HAS BEEN VALIDATED ACCORDING TO TE CONNECTIVITY SPECIFICATIONS 109-18079 (TEST GROUP 1) AND 114-18022. **TE CONNECTIVITY EXPRESSLY DISCLAIMS ANY AND ALL WARRANTIES THAT THE PRODUCT WILL PERFORM SIMILARLY TO VALIDATED AND APPROVED APPLICATIONS, AS STATED WITHIN TE CONNECTIVITY APPLICATION SPECIFICATIONS, INCLUDING BUT NOT LIMITED TO IMPLIED WARRANTIES OF MERCHANTABILITY OR FITNESS FOR PARTICULAR PURPOSE.** AS SUCH, IT IS HIGHLY RECOMMENDED THAT THE CUSTOMER PERFORM FURTHER DETAILED EVALUATION TO ASSESS PRODUCT PERFORMANCE IN THE SPECIFIC APPLICATION.
- 8 THIS APPLICATOR IS EQUIPPED WITH THE DOUBLE ACTING PNEUMATIC FEED WITH SENSORS, AND IS APPLICATION SPECIFIC AND DOES NOT REQUIRE ITEMS 49 & 248.
- 9 TERMINAL LUBRICANT IS RECOMMENDED.
- 10. UNLESS SPECIFIED OTHERWISE TORQUE VALUES SHALL BE USED PER DOCUMENT, 101-35000.

***WARNING**
 ON INSTALLATION, SET WIRE DISC TO CRIMP HEIGHT REFERENCE SETTING FOR LARGEST WIRE SIZE. CRIMP HEIGHT REFERENCE SETTINGS GREATER THAN THE VALUE SHOWN MAY CAUSE DAMAGE TO THE CRIMP TOOLING, REFER TO THE INSTRUCTION SHEET FOR PROPER SETUP AND ADJUSTMENTS.

ATLANTIC VERSION
 Shown on sheets 1 of 4 & 2 of 4
 (Pacific version shown on sheets 3 of 4 & 4 of 4)

LOC	DIST	REVISIONS					
A	66	P	LTN	DESCRIPTION	DATE	DWN	APVD
		K		ECR-19-005438	04APR2019	LG	TE
		L		ECR-22-125942	06JAN2022	RK	JH
		L1		ECR-22-149365	15AUG2022	FZ	YY
		L2		ECR-22-150515	25AUG2022	ROY	TLE

-	-	-	1	1	-	-	-	1803515-3	RAM ASSEMBLY, SF ATLANTIC	293	
-	-	-	1	1	-	-	-	2-1803583-1	APPLICATOR BASIC ASSEMBLY, SF	292	
-	-	-	-	-	1	-	-	2844950-1	AIR FEED MODULE	290	
8	-	1	-	1	-	1	-	2119641-1	FEED CAM, AIR FEED	248	
-	1	1	1	1	1	1	1	2119082-4	CAM, SNAIL, INSULATION ADJUSTMENT	244	
-	1	1	1	1	1	1	1	2079764-1	WASHER, WAVE SPRING, CREST-TO-CREST	243	
3	-	1	1	1	1	1	1	2119083-1	RETAINER, INSULATION DIAL	242	
-	1	1	1	1	1	1	1	7-18023-7	SCR, SKT HD CAP M3 X 4.0	241	
-	-	1	-	1	-	-	1	2119580-1	MECHANICAL FEED ASSEMBLY	239	
-	1	-	1	-	-	1	-	2844940-1	AIR FEED MODULE	238	
-	-	-	1	1	-	-	-	4-1722335-3	STRIPPER, SIDE FEED	182	
-	-	-	1	1	-	-	-	1-5018030-0	NUT, HEX, REG, RoHS, M3.5	181	
3	-	-	1	1	-	-	-	2-1752354-0	STANDOFF,HOLD-DOWN	180	
-	-	-	1	1	-	-	-	993111-1	PIN, SLOTTED SPRING 3.0 X 20.0	177	
-	-	-	1	1	-	-	-	5-22280-0	SPRING, COMPRESSION	176	
-	-	-	1	1	-	-	-	1752353-3	GUIDE PIN,HOLDDOWN	175	
-	-	-	1	1	-	-	-	1901680-2	GUIDE PIN,HOLDDOWN	174	
-	REF	REF	REF	REF	REF	REF	REF	994970-2	COUNTER, MAGNETIC	164	
9	-	1	1	1	1	1	1	2119955-1	ASSY, LUBRICATOR, SIDE FEED	113	
-	1	1	1	1	1	1	1	2844908-1	SCREW, LOCKING	99	
-	1	1	1	1	1	1	1	2844907-1	POST, LOCKING	98	
-	1	1	1	1	1	1	1	455888-5	SPACER, CRIMPER	82	
-	1	1	1	1	1	1	1	1803607-3	DOCUMENTATION PACKAGE	71	
-	1	1	1	1	1	1	1	2119791-5	DEPRESSOR, WIRE	70	
-	1	1	1	1	1	1	1	2119943-1	WASHER, SPACER	69	
-	1	1	1	1	1	1	1	2119740-1	TAG, IDENTIFICATION	67	
-	2	2	2	2	2	2	2	2168078-1	SCREW, DRIVE, RH, RoHS, 2 x .188	66	
-	1	1	1	1	1	1	1	2168083-2	SCR, SKT HD CAP, RoHS, M4 X 8.0	60	
-	1	1	1	1	1	1	1	5-18022-5	SCR, HEX HD CAP, M4 X 6.0	59	
6	-	1	1	1	1	1	1	985575-3	SCR, FLT SKT HD CAP M3 X 10.0	57	
-	1	1	1	1	1	1	1	1338685-1	PAWL, FEED	56	
-	4	4	4	4	4	4	4	2168083-3	SCR, SKT HD CAP, RoHS, M4 X 12.0	54	
-	2	2	2	2	2	2	2	2168083-8	SCR, SKT HD CAP, RoHS, M4 X 16	53	
-	1	1	1	1	1	1	1	5018030-1	NUT, HEX, REG, RoHS, M3	52	
-	1	1	1	1	1	1	1	811242-5	BUMPER, HOLD DOWN	51	
-	1	1	1	1	1	1	1	690753-2	SPACER, TONKER	50	
8	-	1	2	1	2	-	1	2	18023-9	SCR, SKT HD CAP M4 X 6.0	49
-	-	1	-	1	-	-	1	2119652-1	FEED CAM, PRE FEED	48	
-	-	1	-	1	-	-	1	2119653-1	FEED CAM, POST FEED	47	
-	1	1	-	-	1	1	1	1803583-9	APPLICATOR BASIC ASSEMBLY, SF	46	
-	1	1	-	-	1	1	1	1803515-1	RAM ASSEMBLY, SF ATLANTIC	44	
-	1	1	1	1	1	1	1	1803602-1	SCR, BHSC, RoHS (M8 X 25)	41	
-	1	1	1	1	1	1	1	1752356-6	SUPPORT, TERMINAL	34	
-	2	2	2	2	2	2	2	2079383-5	SCR, BHSC, RoHS (M4 X 20)	33	
-	2	2	2	2	2	2	2	2-2844962-8	SPACER, CYLINDRICAL, STRIP GUIDE	30	
-	1	1	1	1	1	1	1	2844992-1	ASSEMBLY, STRIP GUIDE	29	
-	1	1	1	1	1	1	1	455888-3	SPACER, CRIMPER	28	
-	1	1	1	1	1	1	1	1320928-6	STRIP GUIDE	24	
-	1	1	-	-	1	1	1	2168083-2	SCR, SKT HD CAP, RoHS, M4 X 8.0	21	
-	2	2	1	1	2	2	2	1-18028-2	WASHER, FLAT, REG M4	20	
-	1	1	-	-	1	1	1	2119533-1	STRIPPER, SIDE FEED	19	
1	-	1	1	1	1	1	1	2119806-1	INSERT, SHEAR	13	
-	1	1	1	1	1	1	1	3-22280-3	SPRING, COMPRESSION	12	
-	1	1	1	1	1	1	1	1-356885-4	STOP, SHEAR	11	
1	-	1	1	1	1	1	1	2119805-1	SHEAR HOLDER, FRONT	10	
1	-	1	1	1	1	1	1	318707-1	FLOATING SHEAR, FRONT	9	
1	1	2	2	1	1	1	1	1	7-1333201-4	ANVIL, COMBINATION	8
-	1	1	1	1	1	1	1	1	5-240641-0	SPACER	7
-	-	-	-	-	-	-	-	-	-	6	
-	1	1	1	1	1	1	1	1	2-2119781-4	DEPRESSOR, SHEAR	5
-	1	1	1	1	1	1	1	1	238011-4	BLOCK, CRIMPER SPACER	4
1	1	2	2	1	1	1	1	1	1633965-1	CRIMPER, INSULATION O PREMIUM	3
-	1	1	1	1	1	1	1	1	455888-3	SPACER, CRIMPER	2
1	1	2	2	1	1	1	1	1	1-456402-7	CRIMPER, WIRE PREMIUM	1

DIMENSIONS:		TOLERANCES UNLESS OTHERWISE SPECIFIED: 0 PLC ± 1 PLC ± 2 PLC ± 3 PLC ± 4 PLC ± 5 PLC ± ANGLES ±	
MATERIAL	FINISH	WEIGHT	SCALE
DIMENSIONS: mm TOLERANCES UNLESS OTHERWISE SPECIFIED: 0 PLC ±, 1 PLC ±, 2 PLC ±, 3 PLC ±, 4 PLC ±, 5 PLC ±, ANGLES ±		MATERIAL: FINISH: WEIGHT: SCALE:	
DIMENSIONS: mm TOLERANCES UNLESS OTHERWISE SPECIFIED: 0 PLC ±, 1 PLC ±, 2 PLC ±, 3 PLC ±, 4 PLC ±, 5 PLC ±, ANGLES ±		MATERIAL: FINISH: WEIGHT: SCALE:	
DIMENSIONS: mm TOLERANCES UNLESS OTHERWISE SPECIFIED: 0 PLC ±, 1 PLC ±, 2 PLC ±, 3 PLC ±, 4 PLC ±, 5 PLC ±, ANGLES ±		MATERIAL: FINISH: WEIGHT: SCALE:	

Customer Accessible Production Drawing SCALE 1:2 SHEET 1 of 4 REV L2

LOC		DIST		REVISIONS			
A	66	P	LTN	DESCRIPTION	DATE	OWN	APVD
		-		SEE SHEET 1			

FEED TYPE MECHANICAL

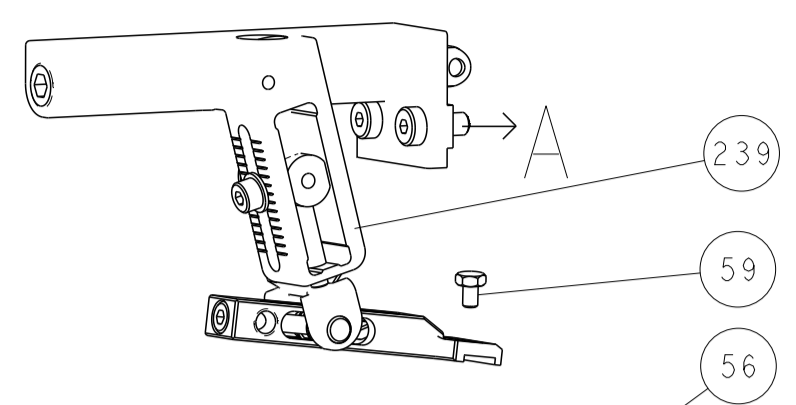

PNEUMATIC

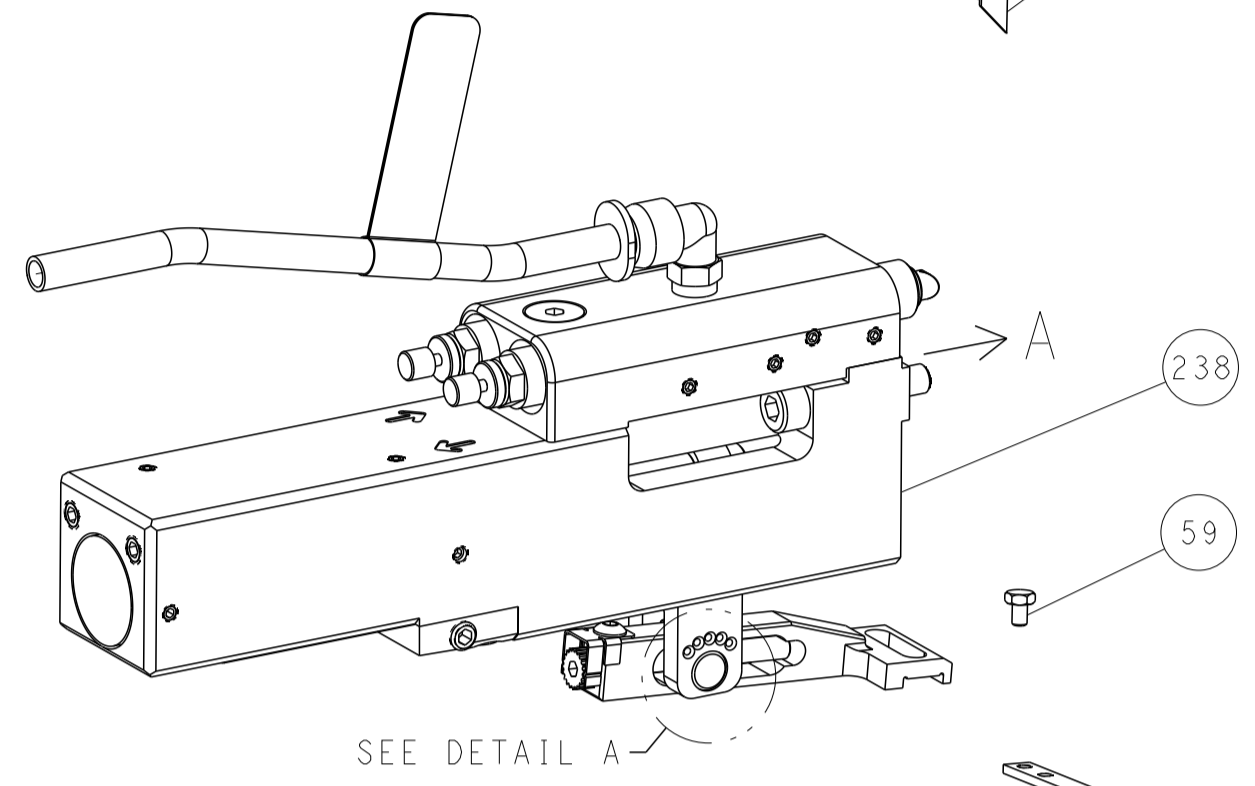

FEED SPRING SETTING POSITION (SHOWN FROM REAR SIDE)

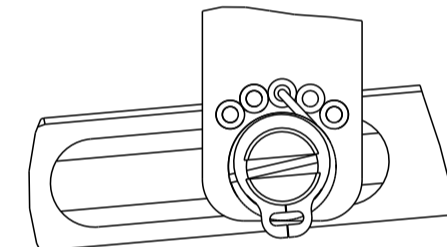

DETAIL A

DOUBLE ACTING PNEUMATIC WITH SENSORS

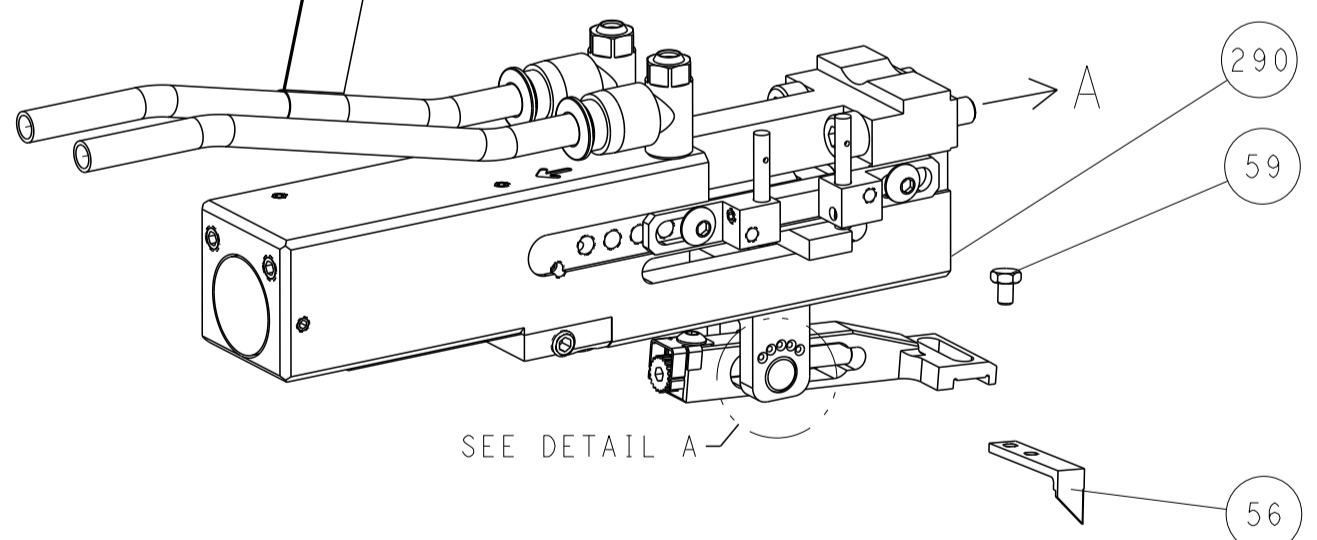

CAM POSITIONS

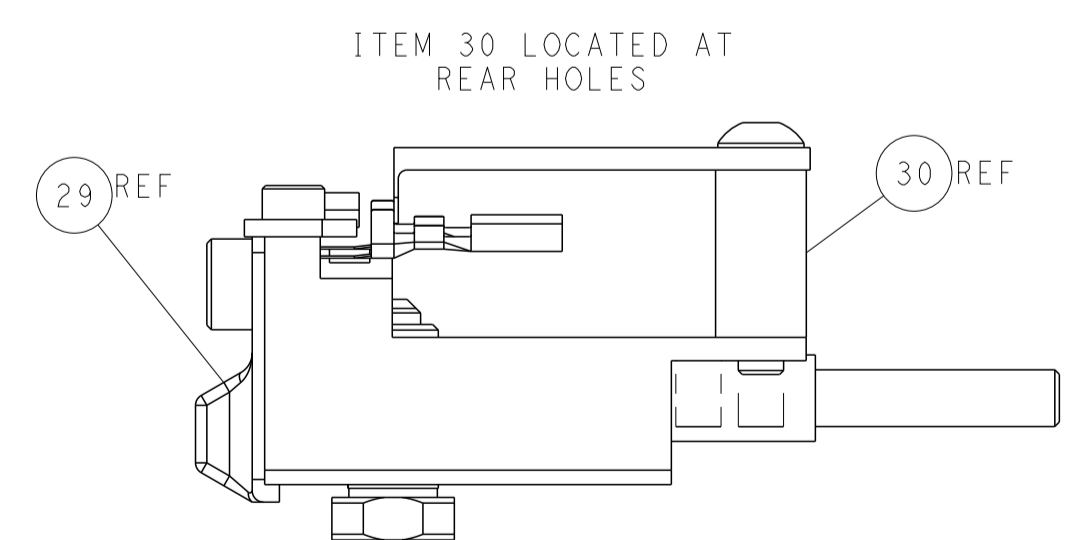
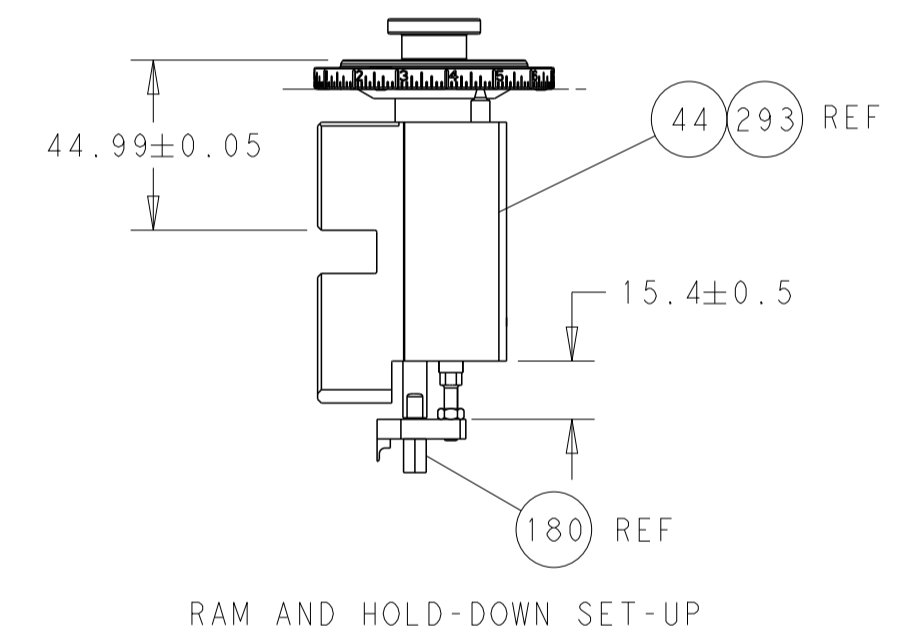
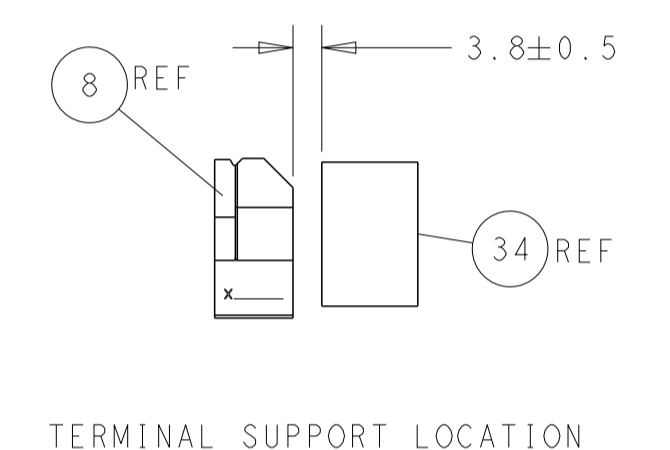
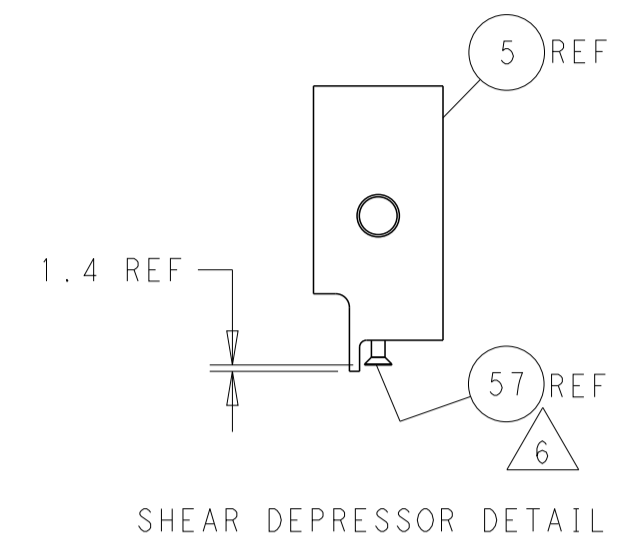
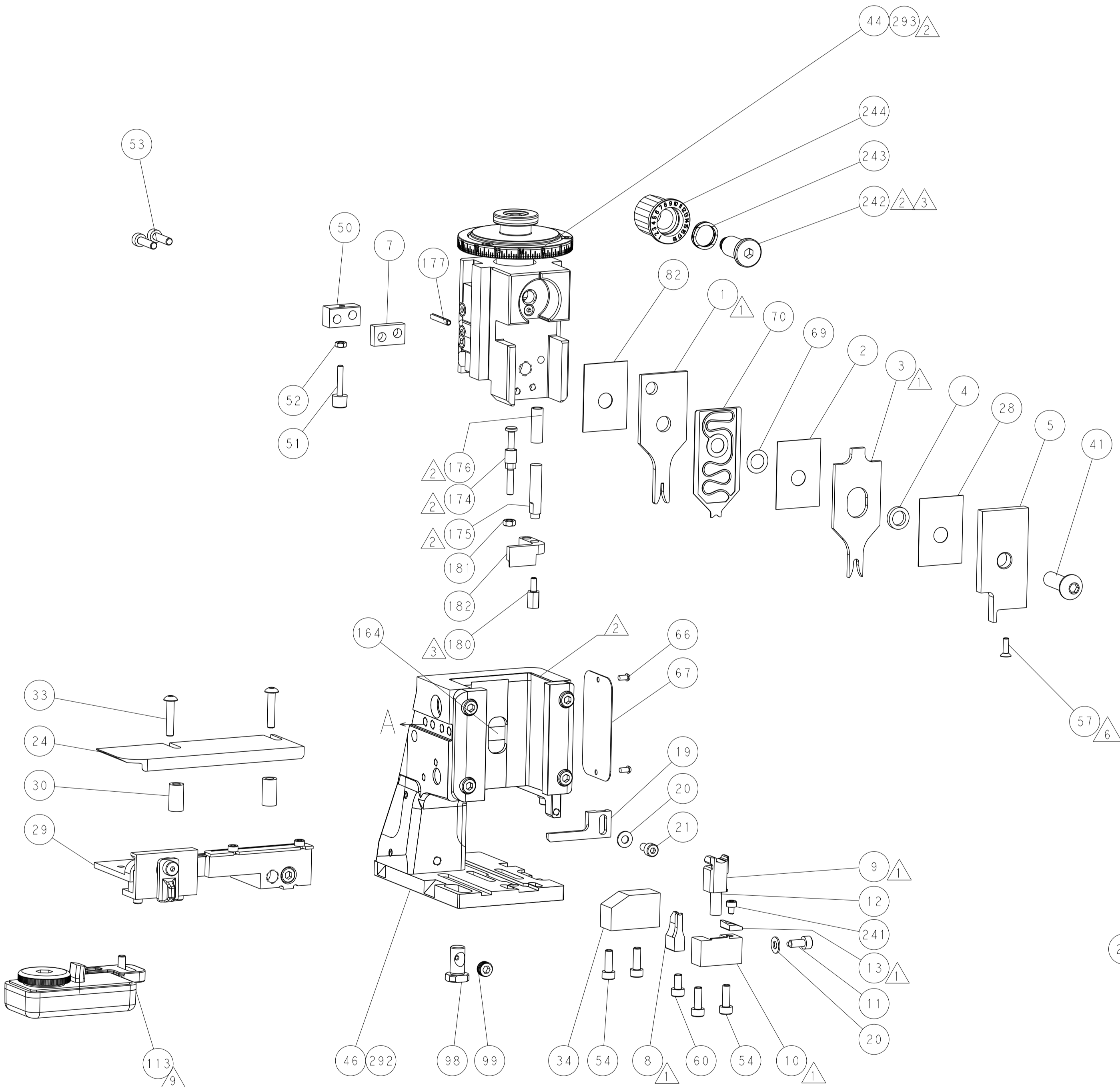
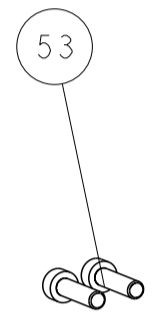
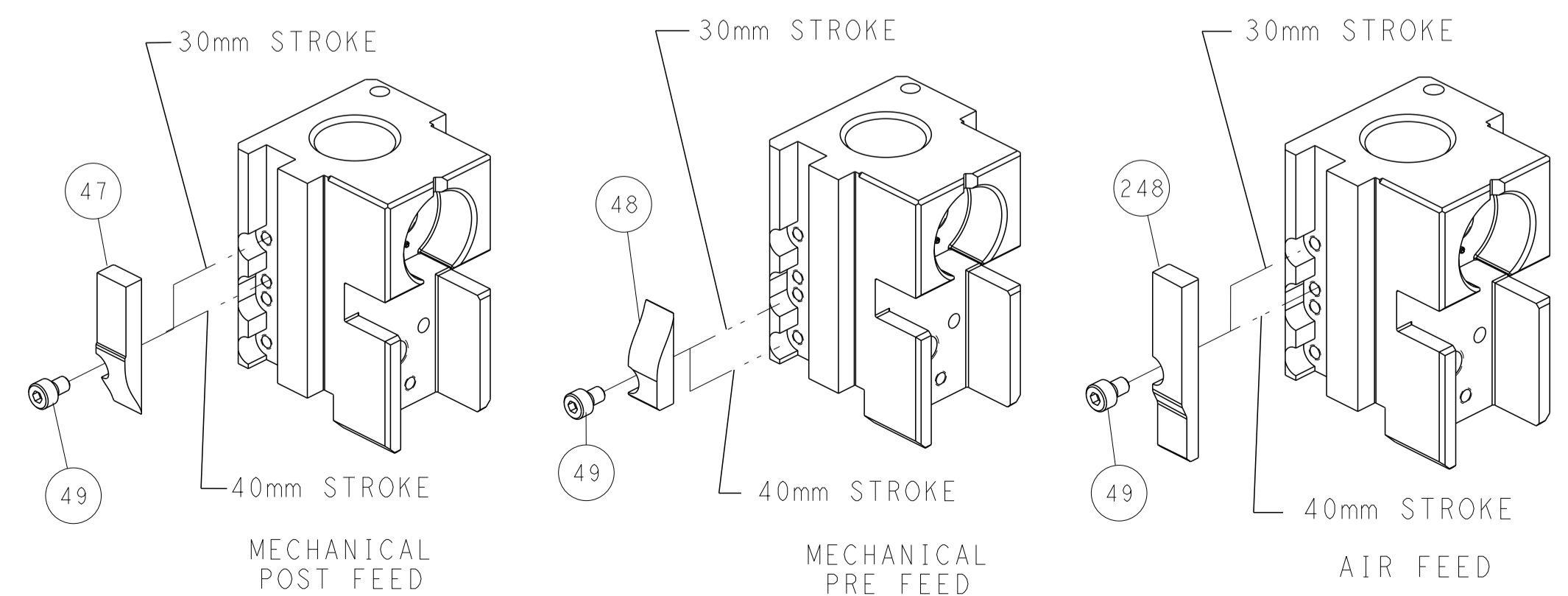

ATLANTIC VERSION
 Shown on sheets 1 of 4 & 2 of 4
 (Pacific version shown on sheets 3 of 4 & 4 of 4)

<small>THIS DRAWING IS UNPUBLISHED. RELEASED FOR PUBLICATION. ALL RIGHTS RESERVED. © 2012 BY TYCO ELECTRONICS CORPORATION.</small>		DWN BOB HIGMAN 02APR2012 CHK T. ELBIN 02APR2012 APVD M. CLIFFORD 02APR2012 PRODUCT SPEC APPLICATION SPEC WEIGHT SCALE 1:2 SHEET 2 OF 4 REV L2		TE Connectivity Harrisburg, PA 17105-3608 NAME Ocean Side Feed Applicator SIZE CAGE CODE DRAWING NO. RESTRICTED TO A1 00779 C=2151477	
DIMENSIONS: mm TOLERANCES UNLESS OTHERWISE SPECIFIED: 0 PLC ± 1 PLC ± 2 PLC ± 3 PLC ± 4 PLC ± ANGLES ± FINISH		MATERIAL:		Customer Accessible Production Drawing	

PART NUMBER	REVISION	DESCRIPTION	FEED TYPE
2-2151477-1	L	FINE CRIMP HEIGHT ADJUST	MECHANICAL
2-2151477-2	L	FINE CRIMP HEIGHT ADJUST	PNEUMATIC
4-2151477-2	L	FINE CRIMP HEIGHT ADJUST	DOUBLE ACTING PNEUMATIC WITH SENSORS
7-2151477-7	A	CRIMP TOOLING KIT	-

PACIFIC VERSION TERMINATOR INTERFACE ADAPTER

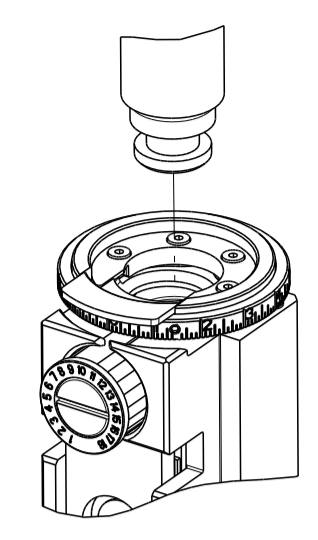

APPLICATOR DATA

CRIMP SIZE	TYPE
WIRE 1.40 mm [.055]	F
INSUL 3.18 mm [.125]	O

APPLICATOR INSTRUCTIONS 408-35042

TERMINAL DATA: TE TERMINAL TE CRIMP SPECIFICATION

TERMINAL NAME: TAB CONTACT 1.2MM

WIRE STRIP LENGTH	INSULATION DIAMETER RANGE
3.30-3.90 mm [.130-.154 IN]	Ø 5

TERMINAL APPLICATION SPECIFICATION 114-18464

TERMINALS APPLIED 9

TE TERMINAL	TE TERMINAL	TE SEAL	TE SEAL
1718760-1	1718760-2	967067-1	963142-2
1718760-3			

WIRE SIZE	CRIMP HEIGHT mm [INCH]	CRIMP HEIGHT REFERENCE SETTING
0.75mm2	1.05+/-0.03 [.041+/-0.001]	5.9
20 AWG OR 0.50mm2	0.93+/-0.03 [.037+/-0.001]	7.2

TERMINAL DATA: TE TERMINAL TE CRIMP SPECIFICATION

TERMINAL NAME: TAB CONTACT 1.2MM

WIRE STRIP LENGTH	INSULATION DIAMETER RANGE
3.30-3.90 mm [.130-.154 IN]	Ø 5

TERMINAL APPLICATION SPECIFICATION 114-18464

TERMINALS APPLIED 9

TE TERMINAL	TE TERMINAL	TE SEAL	TE SEAL
2141116-1	2208328-3	967067-1	963142-2
2141116-3			

WIRE SIZE	CRIMP HEIGHT mm [INCH]	CRIMP HEIGHT REFERENCE SETTING
0.75mm2	0.98+/-0.03 [.039+/-0.001]	6.8
20 AWG OR 0.50mm2	0.93+/-0.03 [.037+/-0.001]	7.2

TERMINAL DATA: TE TERMINAL TE CRIMP SPECIFICATION

TERMINAL NAME: TAB CONTACT 1.2MM

WIRE STRIP LENGTH	INSULATION DIAMETER RANGE
3.30-3.90 mm [.130-.154 IN]	Ø 5

TERMINAL APPLICATION SPECIFICATION

TERMINALS APPLIED 9

TE TERMINAL	TE TERMINAL	TE TERMINAL	TE SEAL
1718760-1	1718760-2	1718760-3	967067-1

WIRE SIZE	CRIMP HEIGHT mm [INCH]	CRIMP HEIGHT REFERENCE SETTING
20 AWG (19 / 0.203 mm)	0.99+/-0.03 [.039+/-0.001]	6.7
0.61mm2	0.99+/-0.03 [.039+/-0.001]	6.7

- RECOMMENDED SPARE PARTS
- REFER TO SUPPLIED INSTRUCTION SHEET FOR CLEANING, LUBRICATION AND STORAGE OF APPLICATOR.
- APPLY PART NUMBER 2-23419-6 LOCTITE TO THREADS OF ITEM 242.
- CRIMP HEIGHT REFERENCE SETTING WAS THE SETTING USED WHEN THE APPLICATOR WAS QUALIFIED AT THE FACTORY. ADJUSTMENT MAY BE NECESSARY WHEN RUNNING APPLICATOR IN THE FIELD.
- THIS APPLICATOR APPLIES TERMINAL WITH A SEAL.

SEAL P/N	INS. Ø
967067-1	1.4-2.1mm
963142-2	0.9-1.3mm
1718760-3	1.4-1.9mm

- APPLY TORQ-SEAL IN ALLEN SOCKET TO FILL HOLE AFTER FLAT HD HAS BEEN ADJUSTED TO CORRECT HEIGHT AT QUALIFICATION. APPLY #1-23419-5 LOC-TITE TO THREADS.
- THIS CRIMP PARAMETER IS PROVIDED TO MEET A CUSTOM AND UNIQUE CUSTOMER REQUIREMENT. IT HAS BEEN EVALUATED AND IS CONDITIONALLY SPECIFIED BY TE CONNECTIVITY. THIS CUSTOMIZED CRIMP PARAMETER IS NOT LISTED AS AN APPROVED APPLICATION WITHIN A TE CONNECTIVITY APPLICATION SPECIFICATION; HOWEVER, IT HAS BEEN VALIDATED ACCORDING TO TE CONNECTIVITY SPECIFICATIONS 109-18079 (TEST GROUP 1) AND 114-18022. **TE CONNECTIVITY EXPRESSLY DISCLAIMS ANY AND ALL WARRANTIES THAT THE PRODUCT WILL PERFORM SIMILARLY TO VALIDATED AND APPROVED APPLICATIONS, AS STATED WITHIN TE CONNECTIVITY APPLICATION SPECIFICATIONS, INCLUDING BUT NOT LIMITED TO IMPLIED WARRANTIES OF MERCHANTABILITY OR FITNESS FOR PARTICULAR PURPOSE.** AS SUCH, IT IS HIGHLY RECOMMENDED THAT THE CUSTOMER PERFORM FURTHER DETAILED EVALUATION TO ASSESS PRODUCT PERFORMANCE IN THE SPECIFIC APPLICATION.

- THIS APPLICATOR IS EQUIPPED WITH THE DOUBLE ACTING PNEUMATIC FEED WITH SENSORS, AND IS APPLICATION SPECIFIC AND DOES NOT REQUIRE ITEMS 49 & 151.
- TERMINAL LUBRICANT IS RECOMMENDED.
- UNLESS SPECIFIED OTHERWISE TORQUE VALUES SHALL BE USED PER DOCUMENT, 101-35000.

***WARNING**
 ON INSTALLATION, SET WIRE DISC TO CRIMP HEIGHT REFERENCE SETTING FOR LARGEST WIRE SIZE. CRIMP HEIGHT REFERENCE SETTINGS GREATER THAN THE VALUE SHOWN MAY CAUSE DAMAGE TO THE CRIMP TOOLING, REFER TO THE INSTRUCTION SHEET FOR PROPER SETUP AND ADJUSTMENTS.

ENTRY LEVEL APPLICATOR		ITEM SUBSTITUTION LIST		
PART NUMBER	SAME AS	ITEM	ITEM DESCRIPTION	SUBSTITUTE PART NUMBER
8-2151477-1	2151477-1	1	WIRE CRIMPER	1-1803530-7
8-2151477-2	2151477-2	3	INSULATION CRIMPER	1803624-1
9-2151477-1	2-2151477-1	46	BASIC SUB -ASSEMBLY	1803940-9
9-2151477-2	2-2151477-2	141	BASIC SUB -ASSEMBLY	1-1803940-0
			LUBRICATOR	DELETE

PACIFIC VERSION
 Shown on sheets 3 of 4 & 4 of 4
 (Atlantic version shown on sheets 1 of 4 & 2 of 4)

LOC	DIST	REVISIONS					
A	66	P	LTN	DESCRIPTION	DATE	OWN	APVD
		-	-	SEE SHEET 1	-	-	-

-	1	-	-	2844950-1	AIR FEED MODULE	290	
-	1	1	1	2119082-4	CAM, SNAIL, INSULATION ADJUSTMENT	244	
-	1	1	1	2079764-1	WASHER, WAVE SPRING, CREST-TO-CREST	243	
3	-	1	1	2119083-1	RETAINER, INSULATION DIAL	242	
-	1	1	1	7-18023-7	SCR, SKT HD CAP M3 X 4.0	241	
-	-	-	1	2119580-1	MECHANICAL FEED ASSEMBLY	239	
-	-	1	-	2844940-1	AIR FEED MODULE	238	
-	REF	REF	REF	994970-2	COUNTER, MAGNETIC	164	
8	-	-	1	2119641-2	FEED CAM, AIR FEED	151	
-	1	1	1	2168083-8	SCR, SKT HD CAP, RoHS, M4 X 16	144	
-	4	4	4	2168083-9	SCR, SKT HD CAP, RoHS, M4 X 20	143	
-	-	-	1	2119653-2	FEED CAM, POST FEED	142	
-	1	1	1	1-1803583-0	APPLICATOR BASIC ASSEMBLY, SF	141	
-	1	1	1	1803516-1	RAM ASSEMBLY, SF PACIFIC	140	
9	-	1	1	2119955-1	ASSY, LUBRICATOR, SIDE FEED	113	
-	1	1	1	2844908-1	SCREW, LOCKING	99	
-	1	1	1	2844907-1	POST, LOCKING	98	
-	1	1	1	455888-5	SPACER, CRIMPER	82	
-	1	1	1	1803607-3	DOCUMENTATION PACKAGE	71	
-	1	1	1	2119791-5	DEPRESSOR, WIRE	70	
-	1	1	1	2119943-1	WASHER, SPACER	69	
-	1	1	1	2119740-1	TAG IDENTIFICATION	67	
-	2	2	2	2168078-1	SCREW, DRIVE, RH, RoHS, 2 x .188	66	
-	1	1	1	5-18022-5	SCR, HEX HD CAP, M4 X 6.0	59	
6	-	1	1	985575-3	SCR, FLT SKT HD CAP M3 X 10.0	57	
-	1	1	1	1338685-1	PAWL, FEED	56	
-	2	2	2	2168083-8	SCR, SKT HD CAP, RoHS, M4 X 16	53	
-	1	1	1	5018030-1	NUT, HEX, REG, RoHS, M3	52	
-	1	1	1	811242-5	BUMPER, HOLD DOWN	51	
-	1	1	1	690753-2	SPACER, TONKER	50	
8	-	-	1	2	18023-9	SCR, SKT HD CAP M4 X 6.0	49
-	-	-	1	2119652-1	FEED CAM, PRE FEED	48	
-	1	1	1	1803602-1	SCR, BHSC, RoHS (M8 X 25)	41	
-	1	1	1	1752356-6	SUPPORT, TERMINAL	34	
-	2	2	2	2079383-5	SCR, BHSC, RoHS (M4 X 20)	33	
-	2	2	2	2-2844962-8	SPACER, CYLINDRICAL, STRIP GUIDE	30	
-	1	1	1	2844992-1	ASSEMBLY, STRIP GUIDE	29	
-	1	1	1	455888-3	SPACER, CRIMPER	28	
-	1	1	1	1320928-6	STRIP GUIDE	24	
-	1	1	1	2168083-2	SCR, SKT HD CAP, RoHS, M4 X 8.0	21	
-	2	2	2	1-18028-2	WASHER, FLAT, REG M4	20	
-	1	1	1	2119533-1	STRIPPER, SIDE FEED	19	
1	-	1	1	1	2119806-1	INSERT, SHEAR	13
-	1	1	1	3-22280-3	SPRING, COMPRESSION	12	
-	1	1	1	1-356885-4	STOP, SHEAR	11	
1	-	1	1	1	2119805-1	SHEAR HOLDER, FRONT	10
1	-	1	1	1	318707-1	FLOATING SHEAR, FRONT	9
1	1	1	1	1	7-1333201-4	ANVIL, COMBINATION	8
-	1	1	1	1	5-240641-0	SPACER	7
-	-	-	-	-	-	6	
-	1	1	1	1	2-2119781-4	DEPRESSOR, SHEAR	5
-	1	1	1	238011-4	BLOCK, CRIMPER SPACER	4	
1	1	1	1	1	1633965-1	CRIMPER, INSULATION O PREMIUM	3
-	1	1	1	1	455888-3	SPACER, CRIMPER	2
1	1	1	1	1	1-456402-7	CRIMPER, WIRE PREMIUM	1

DIMENSIONS:		TOLERANCES UNLESS OTHERWISE SPECIFIED:		DWG		REV	
mm	0 PLC ±	1 PLC ±	2 PLC ±	3 PLC ±	4 PLC ±	5 PLC ±	ANGLES ±
MATERIAL	FINISH	WEIGHT	SCALE	SIZE	CAGE CODE	DRAWING NO	RESTRICTED TO
				A1	00779	2151477	

Customer Accessible Production Drawing

FEED TYPE MECHANICAL

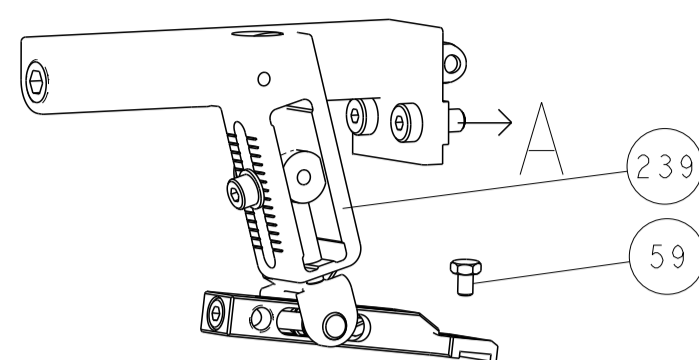

PNEUMATIC

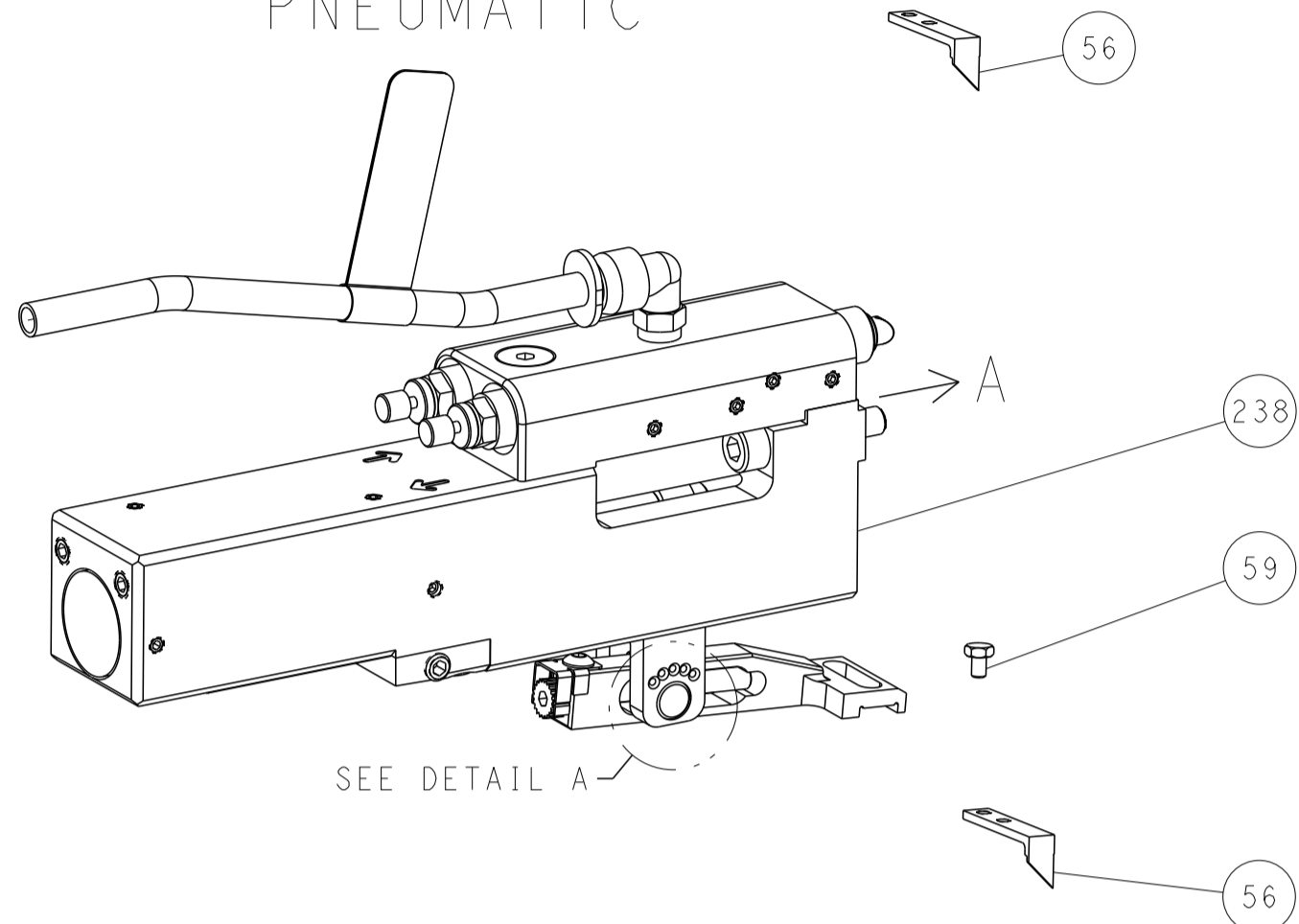

FEED SPRING SETTING POSITION (SHOWN FROM REAR SIDE)

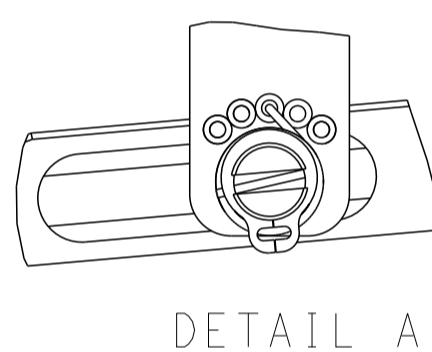

DETAIL A

DOUBLE ACTING PNEUMATIC WITH SENSORS

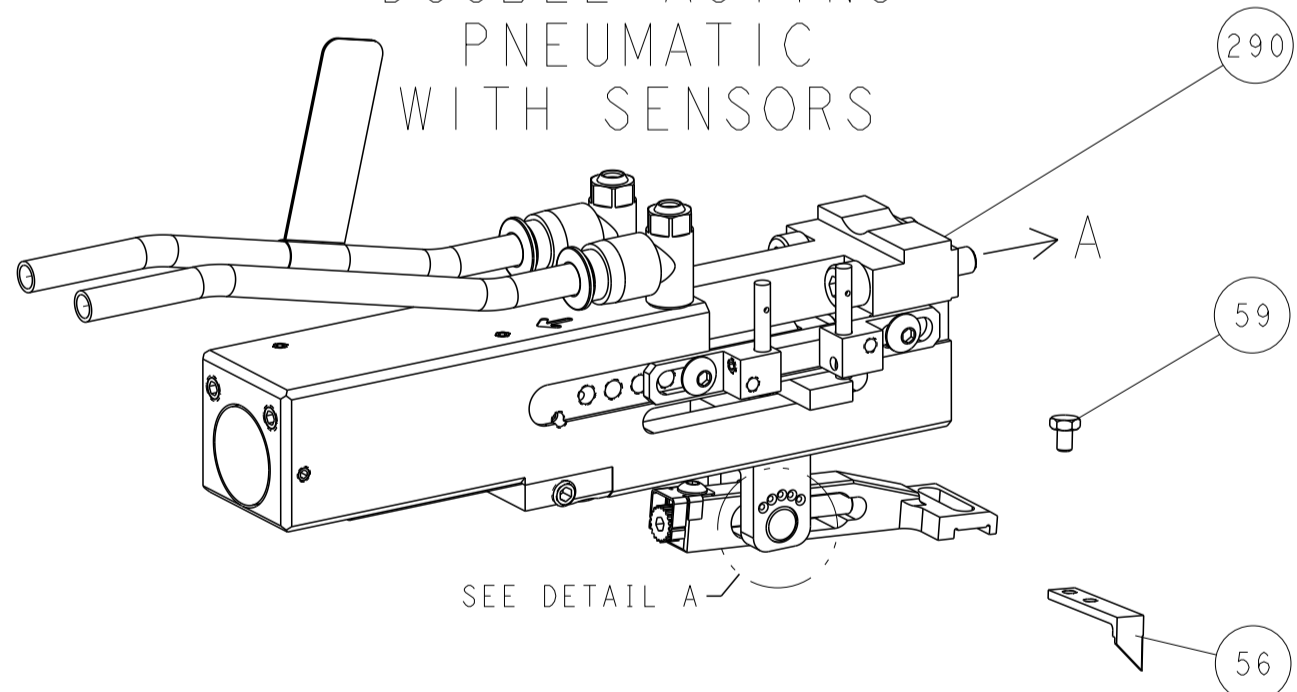

SEE DETAIL A

CAM POSITIONS

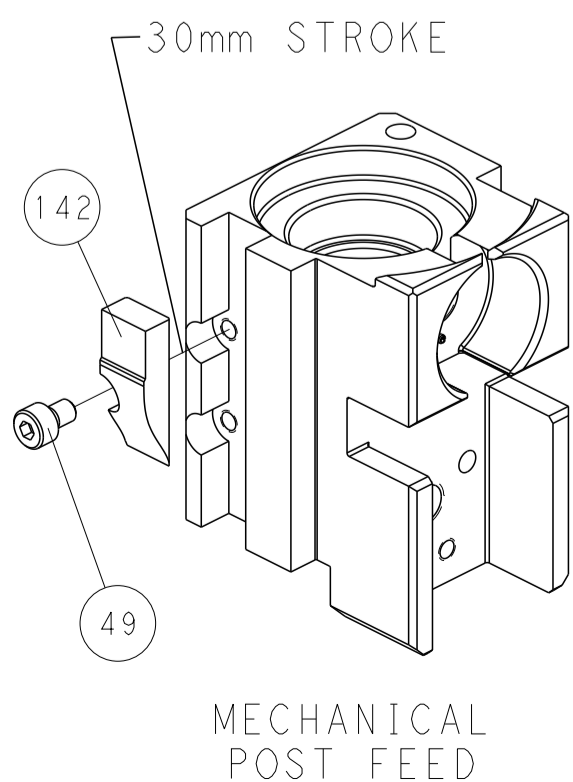

MECHANICAL POST FEED

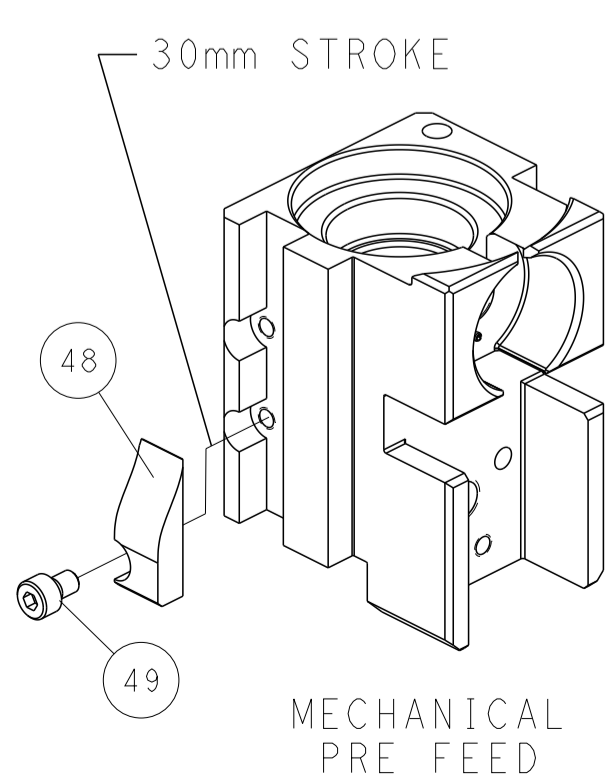

MECHANICAL PRE FEED

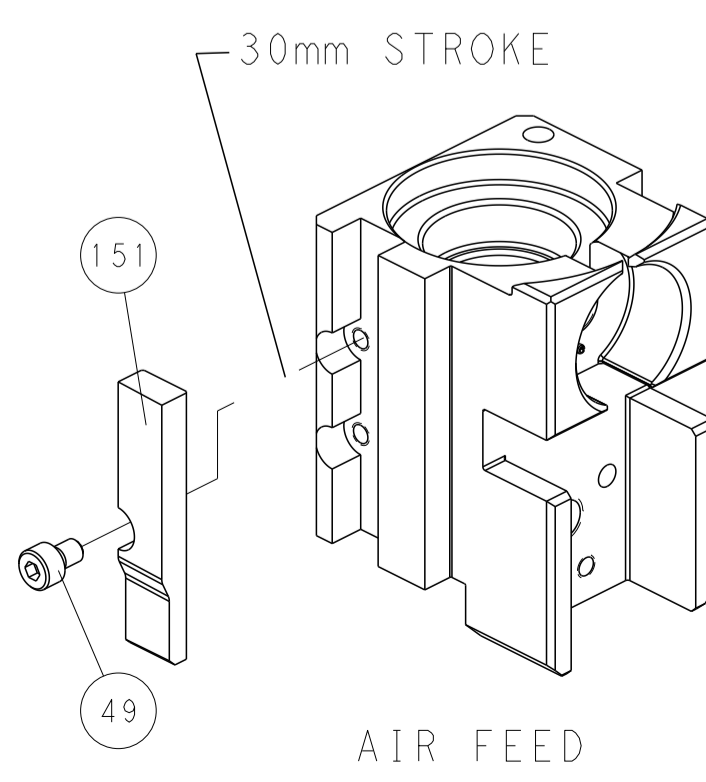

AIR FEED

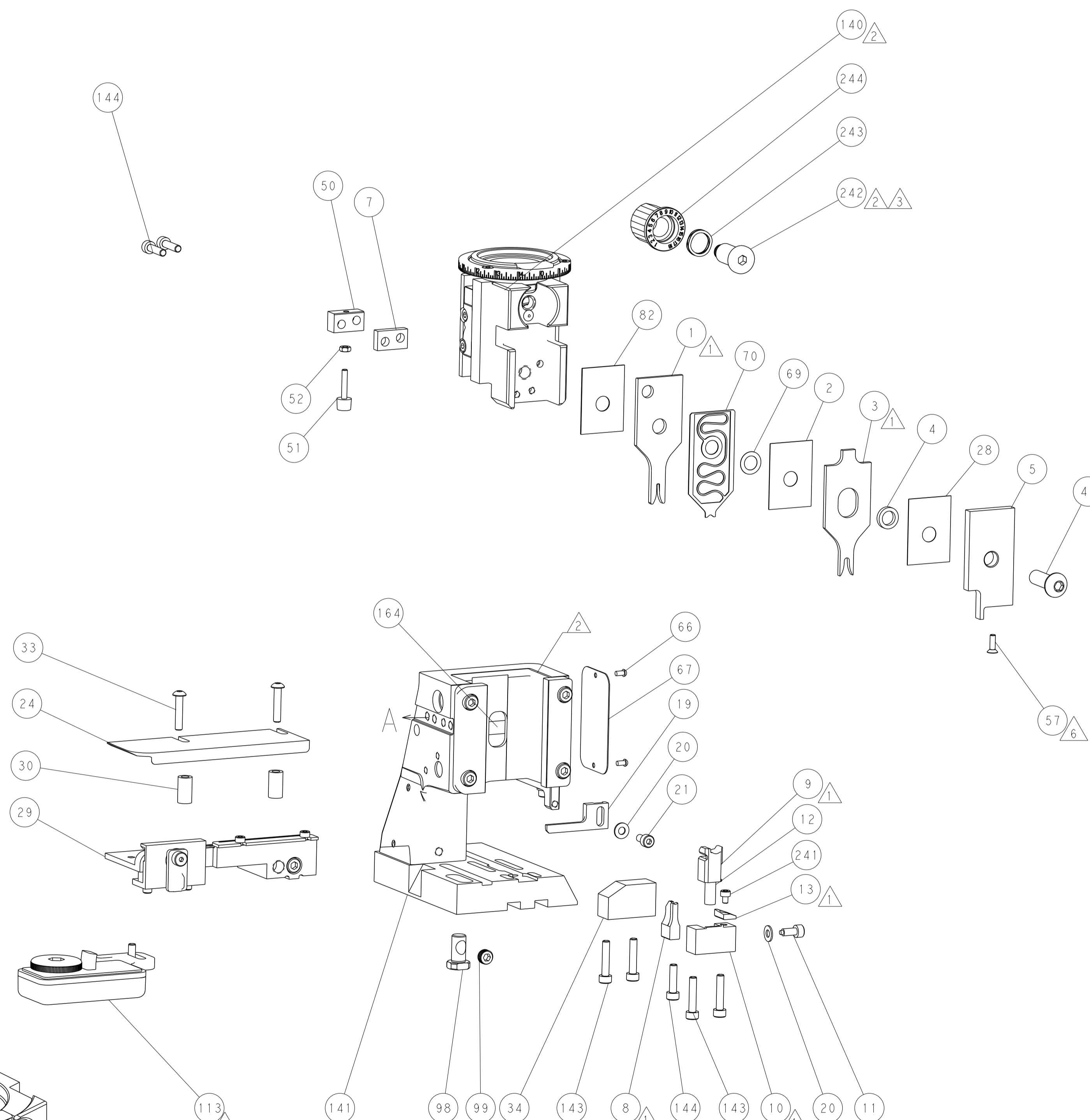

PACIFIC VERSION
 Shown on sheets 3 of 4 & 4 of 4
 (Atlantic version shown on sheets 1 of 4 & 2 of 4)

LOC	DIST	REVISIONS					
A	66	P	LTN	DESCRIPTION	DATE	OWN	APVD
		-		SEE SHEET 1			

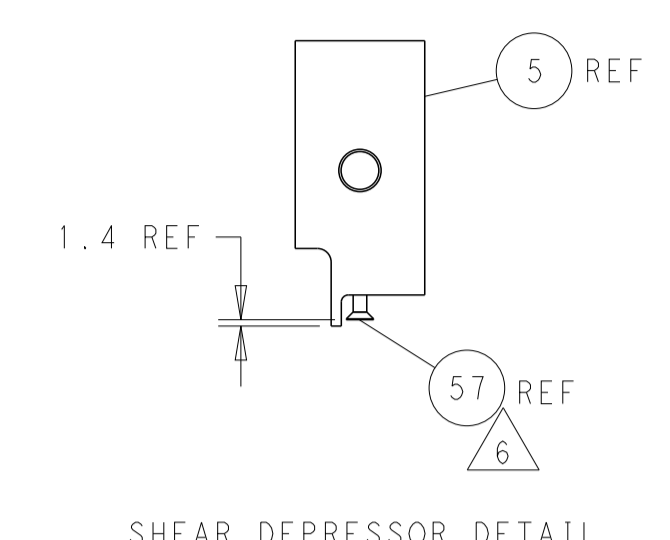

SHEAR DEPRESSOR DETAIL

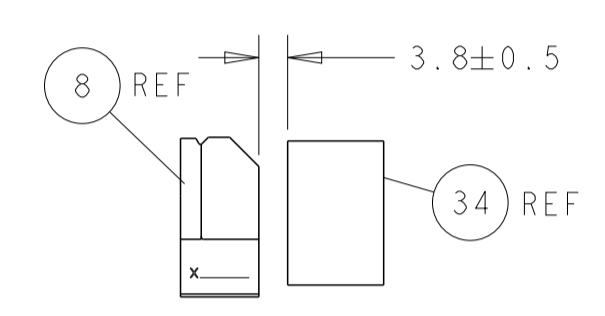

TERMINAL SUPPORT LOCATION

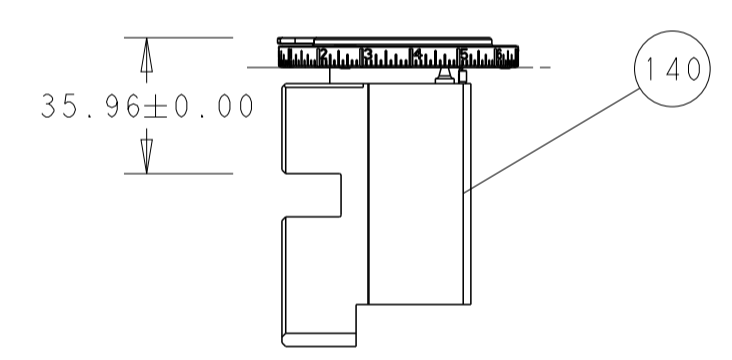

RAM SET-UP

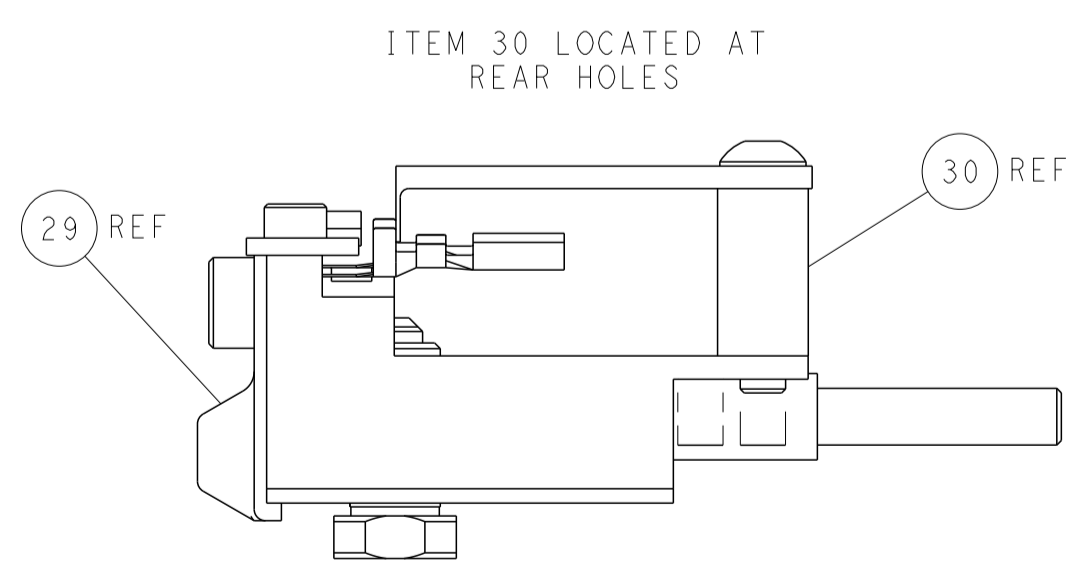

FEED TRACK POSITION GUIDE BY INSULATION BARREL

<small>THIS DRAWING IS UNPUBLISHED. RELEASED FOR PUBLICATION BY TYCO ELECTRONICS CORPORATION. ALL RIGHTS RESERVED. COPYRIGHT 2000.</small>		DWN BOB HIGMAN 02APR2012 CHK T. ELBIN 02APR2012 APVD M. CLIFFORD 02APR2012		TE Connectivity Harrisburg, PA 17105-3608	
DIMENSIONS: mm TOLERANCES UNLESS OTHERWISE SPECIFIED: 0 PLC ± 1 PLC ± 2 PLC ± 3 PLC ± 4 PLC ± ANGLES ± FINISH		NAME: Ocean Side Feed Applicator SIZE: A1 CAGE CODE: 00779 DRAWING NO: 2151477 SCALE: 1:2 SHEET: 4 OF 4 REV: L2		RESTRICTED TO:	
MATERIAL:		WEIGHT:		Customer Accessible Production Drawing	