

LOC	DIST	REVISIONS					
AG	00	P	LTH	DESCRIPTION	DATE	DWN	APVD
		E2		REVISED PER ECR-18-007695	31MAY2018	BW	RS
		E3		REVISED PER ECR-20-004158	26MAR2020	ED	RS
		F		REVISED PER ECR-20-013676	25SEP2020	ED	RS

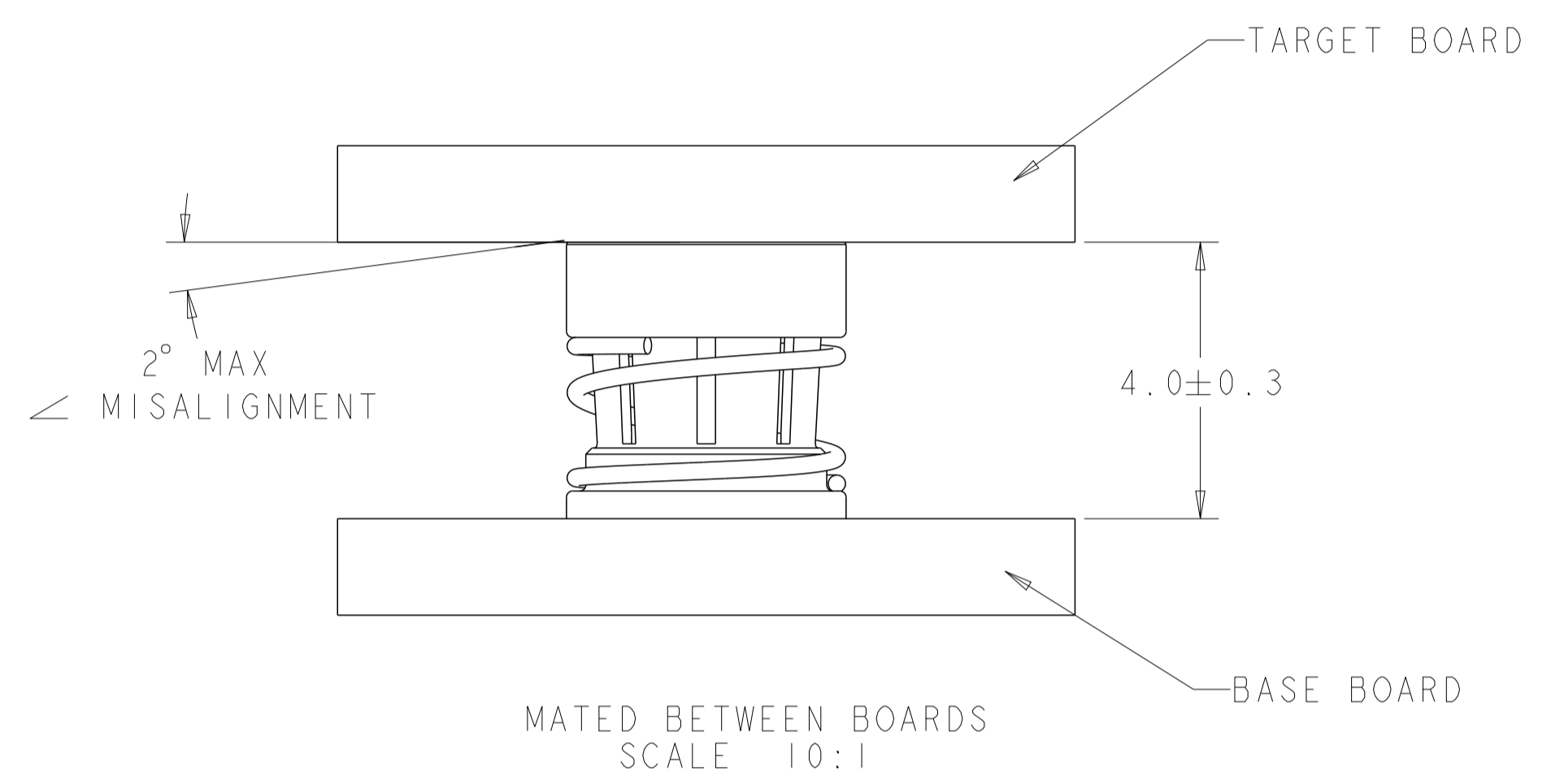

- 1 POSITION CENTER CONTACT
- 2 MATERIAL: PHOS - BRONZE, PLATING: 0.3um MIN GOLD OVER 1.27um MIN NICKEL.
- 3 MATERIAL: BRASS, PLATING: 0.3um MIN GOLD OVER 1.27um MIN NICKEL.
- 4 MISALIGNMENT BETWEEN CONNECTOR AXIS AND TARGET PAD, 0.80 mm MAX.
- 5 MATERIAL: PTFE

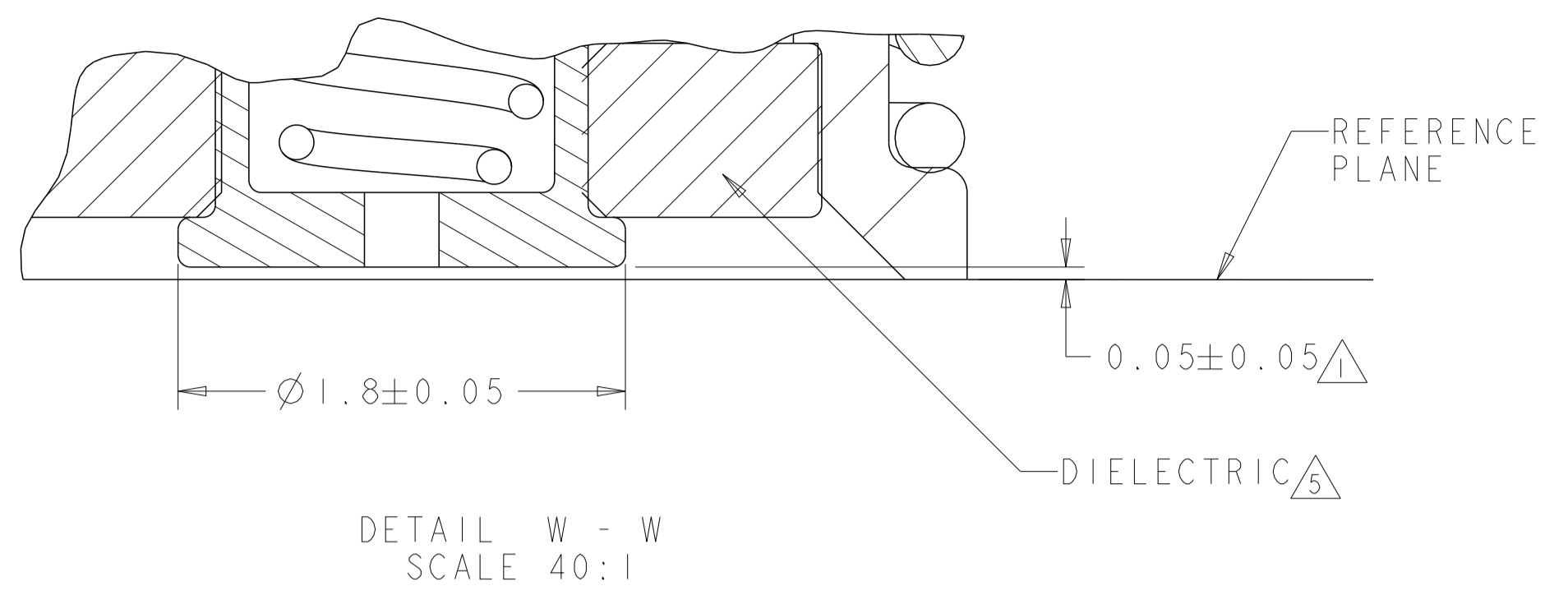
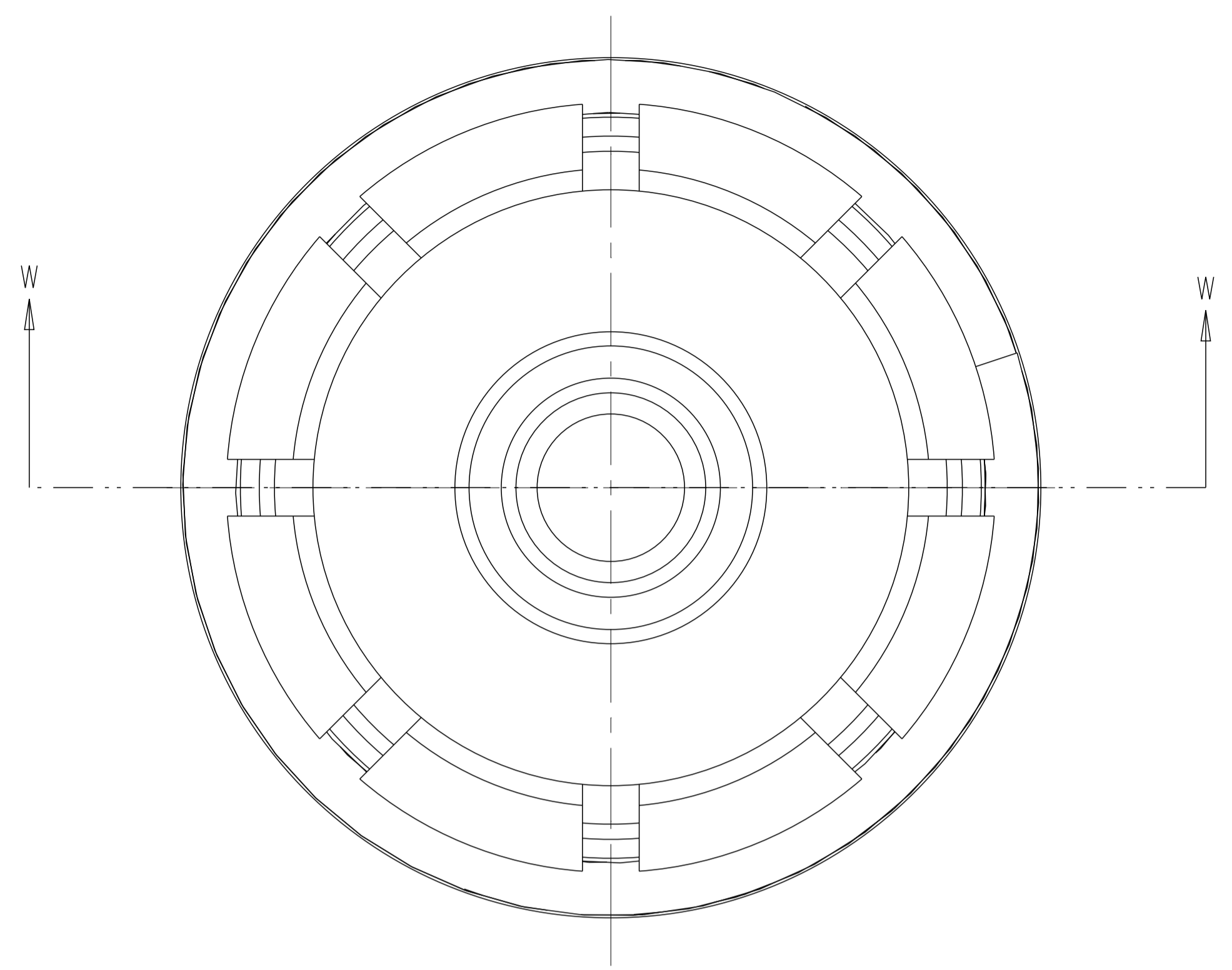
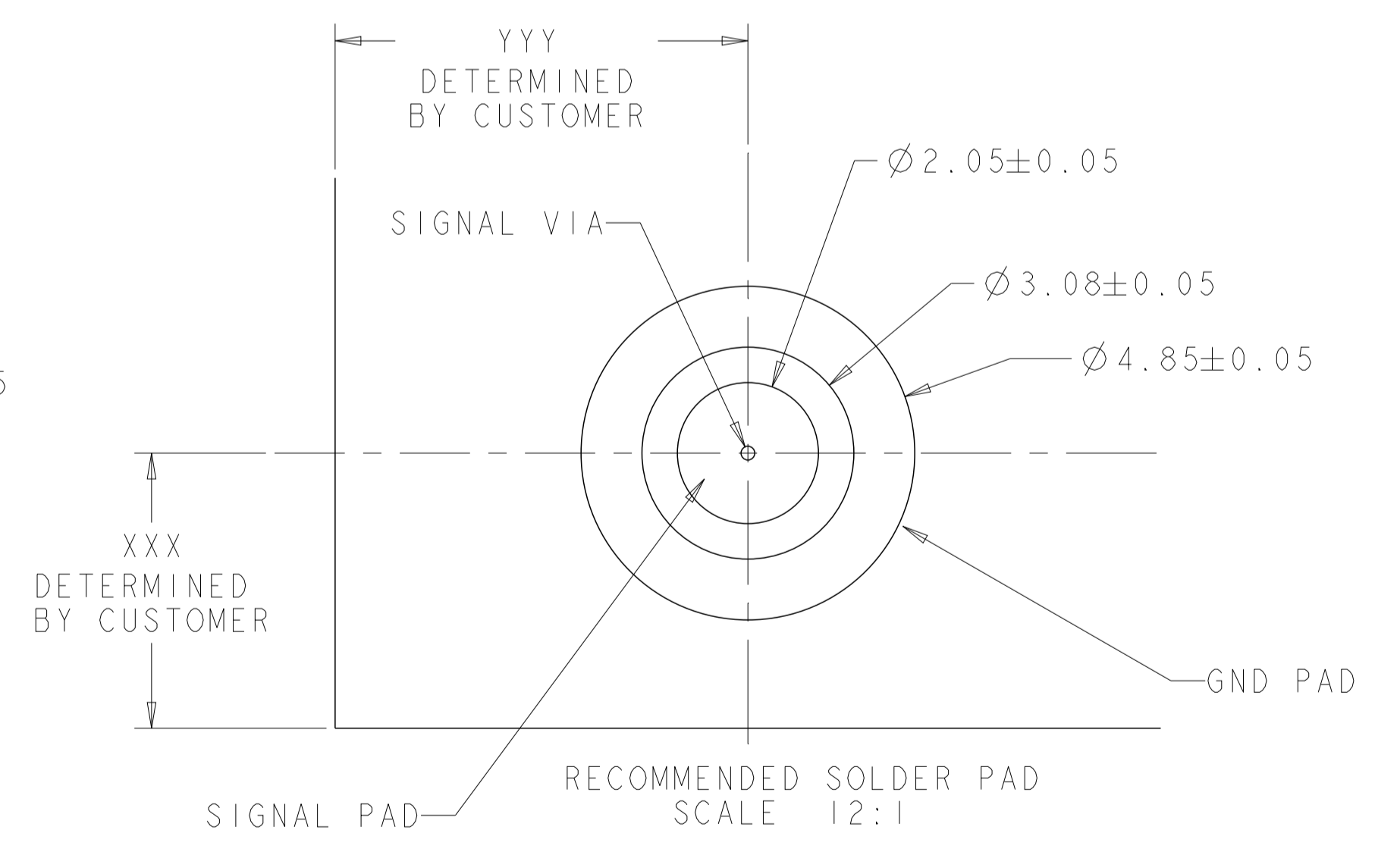
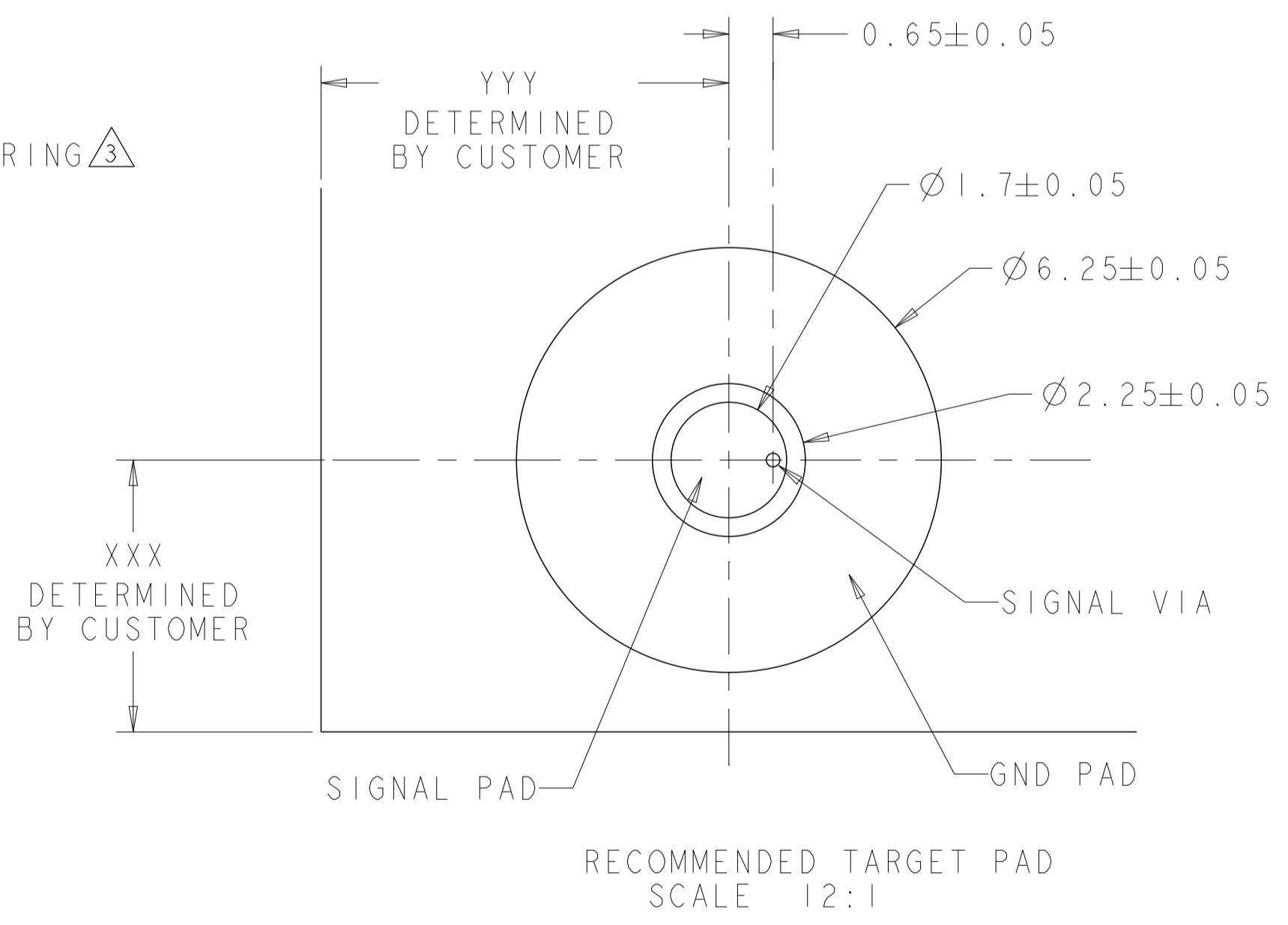
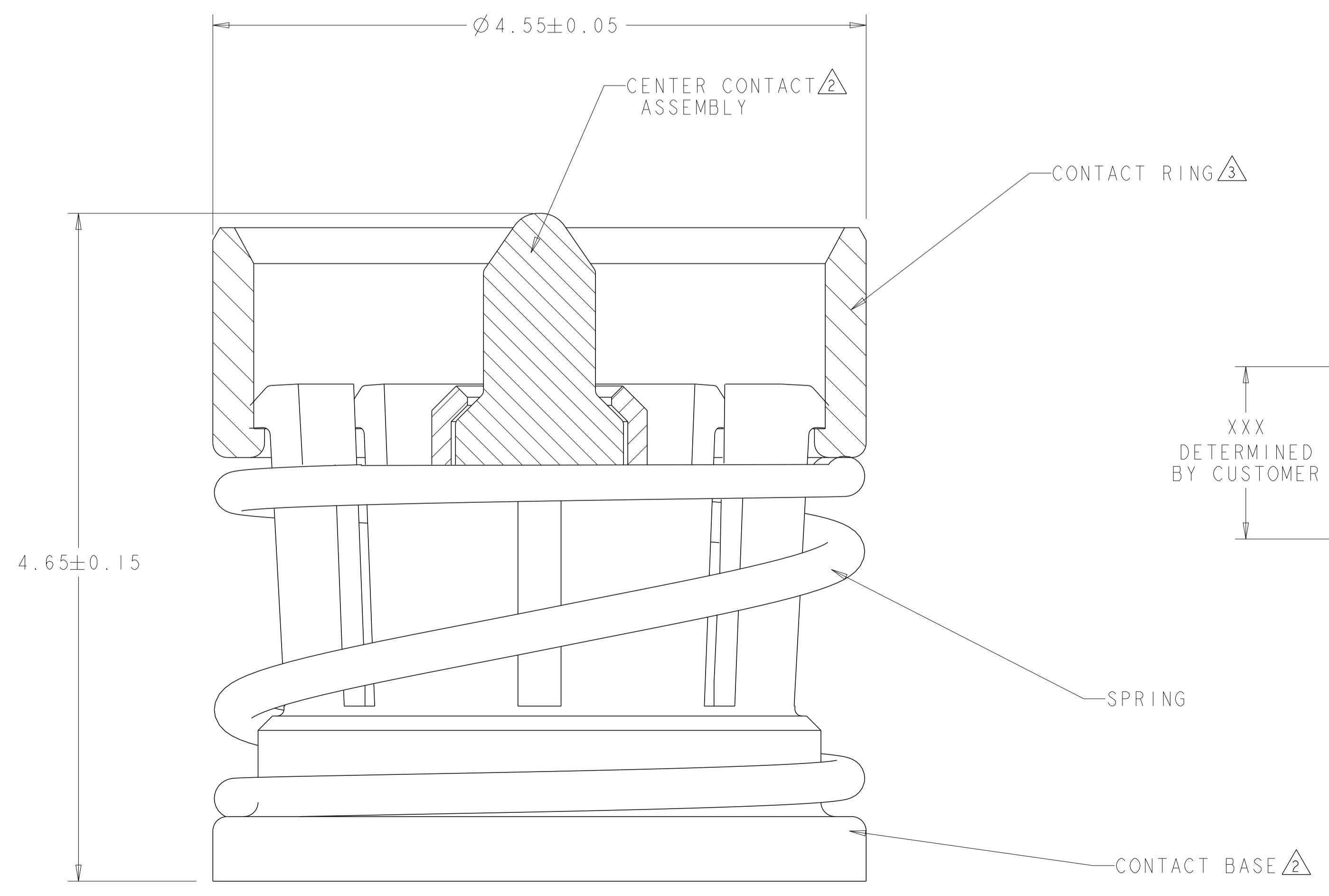
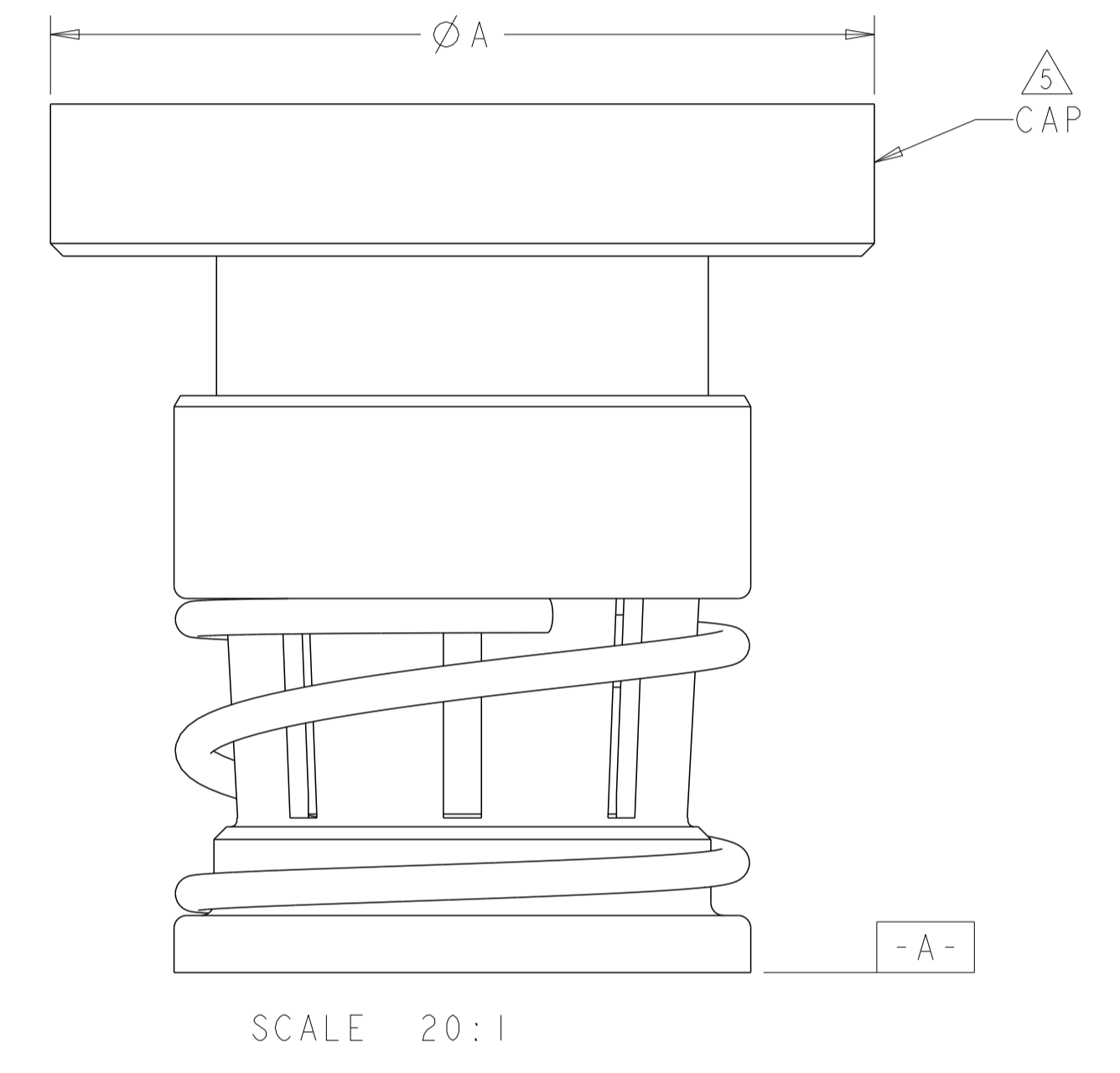

"A"	QTY	DESCRIPTION	PART NUMBER
4.8	750	REELED CONNECTOR	1-1658260-2
4.8	L/P	COAX CONNECTOR	1-1658260-1
6.5	750	REELED CONNECTOR	1658260-2
6.5	L/P	COAX CONNECTOR	1658260-1

THIS DRAWING IS A CONTROLLED DOCUMENT.

STE TE Connectivity

CONNECTOR, COAXIAL, BOARD TO BOARD
4.0 mm HEIGHT

SCALE 40:1 SHEET 1 OF 2 REV F

LOC		DIST		REVISIONS			
P	LYN	DESCRIPTION	DATE	DWN	APVD		
-	-	SEE SHEET 1	-	-	-		

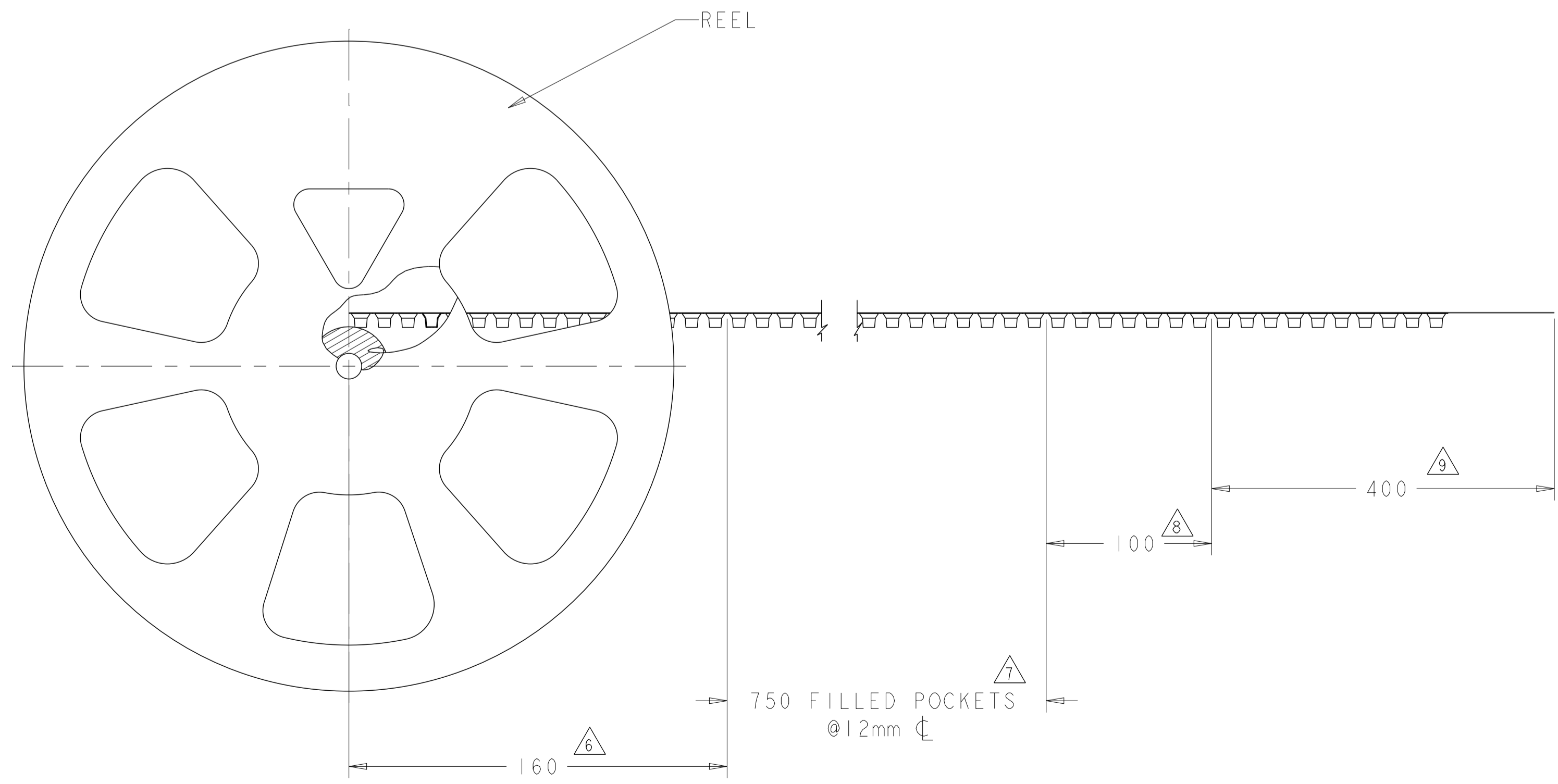
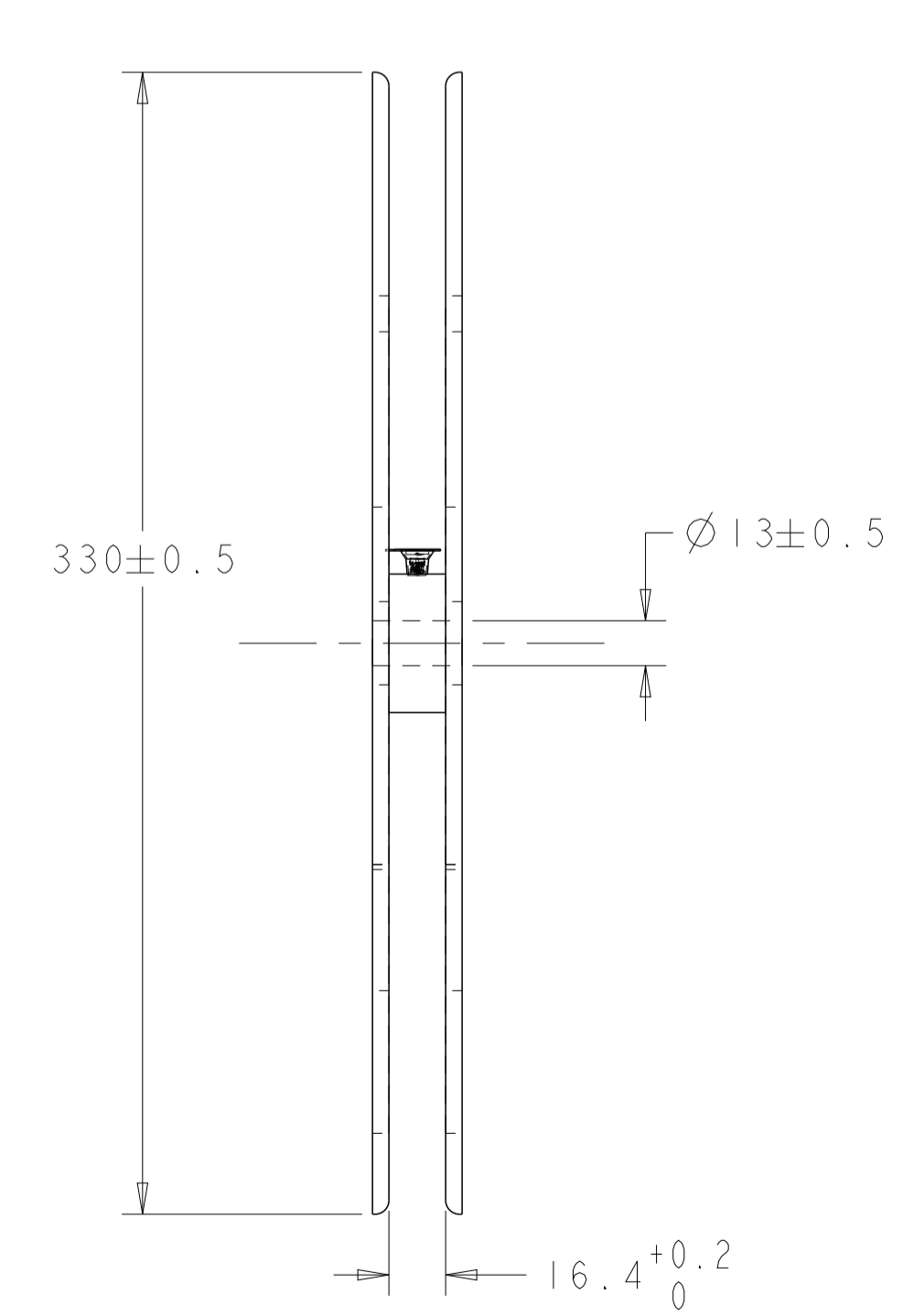
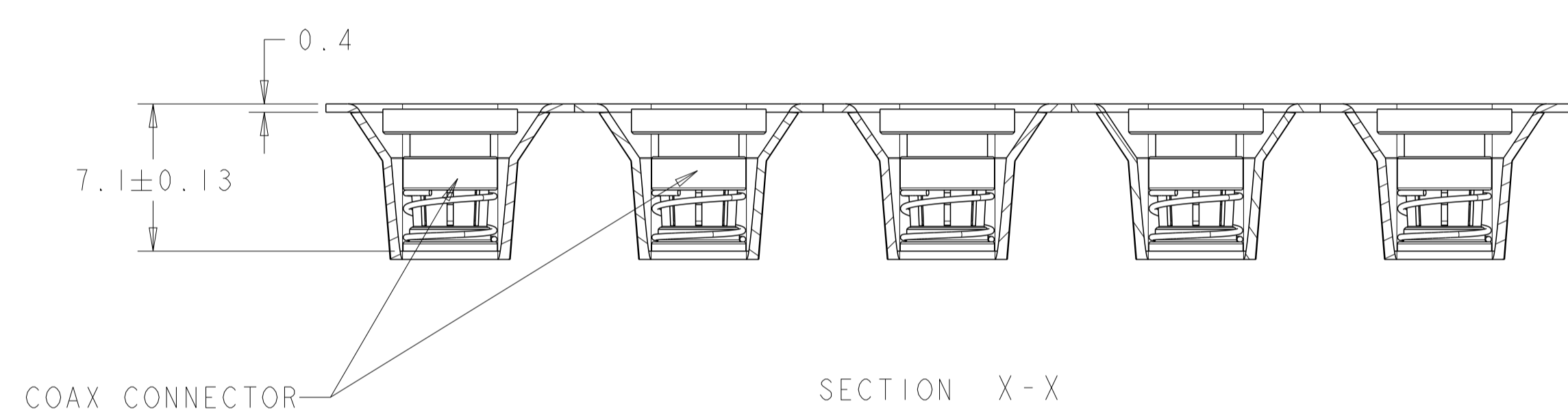
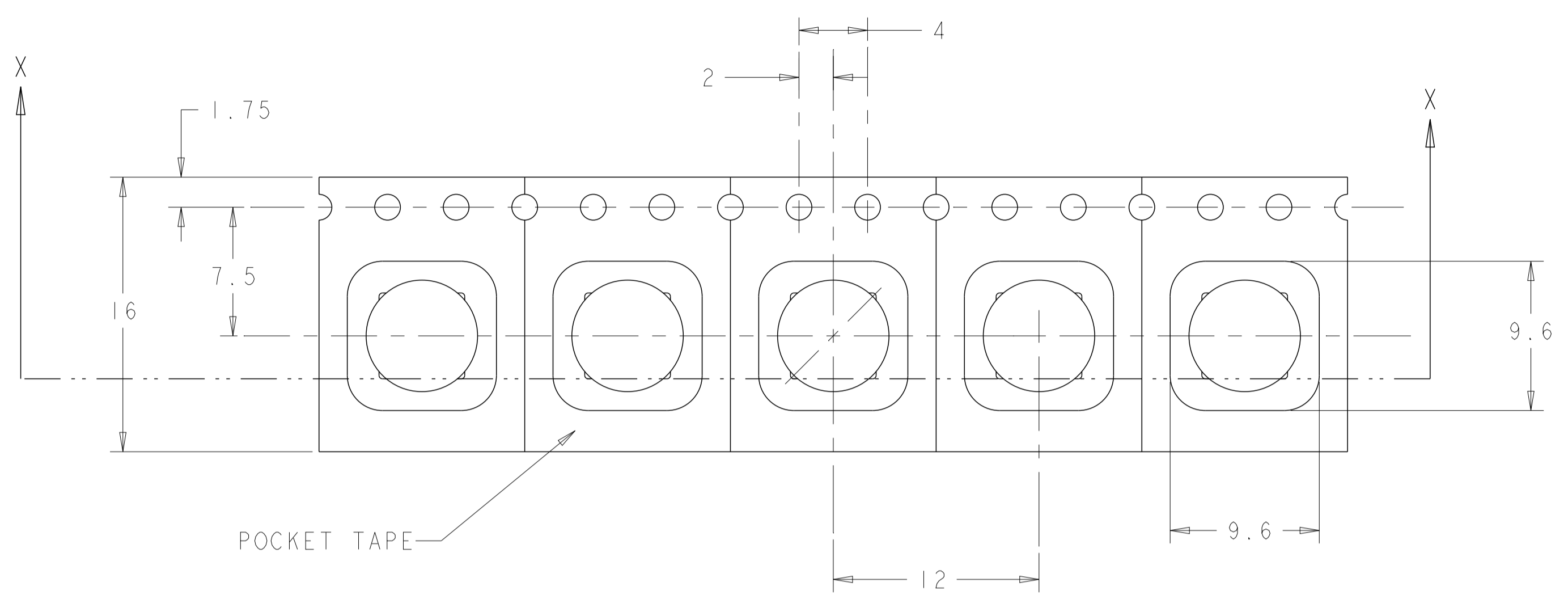

- △ 6 TRAILER, EMPTY POCKETS WITH COVER TAPE.
- △ 7 CARRIER POCKETS FILLED WITH 1658260-2, WITH COVER TAPE.
- △ 8 LEADER, EMPTY POCKETS WITH COVER TAPE.
- △ 9 LEADER COVER TAPE.
- 10. REELED PRODUCT PER SPEC EIA 481

THIS DRAWING IS A CONTROLLED DOCUMENT.		DWN: JIM VAN SCOY 21 JAN 2003	 TE Connectivity
DIMENSIONS: mm		CHK: M. PHILLIPS 21 JAN 2003	
TOLERANCES UNLESS OTHERWISE SPECIFIED:		APVD: M. PHILLIPS 21 JAN 2003	NAME: CONNECTOR, COAXIAL, BOARD TO BOARD 4.0 mm HEIGHT
0 PLC	±	PRODUCT SPEC	SIZE: A1
1 PLC	±0.2	APPLICATION SPEC	CAGE CODE: C=1658260
2 PLC	±0.05	WEIGHT	SCALE: 40:1
3 PLC	±	CUSTOMER DRAWING	SHEET: 2 OF 2
4 PLC	±		REV: F
ANGLES	±1°		
FINISH			