

DESCRIPTION

The EV2456-J-00A is an evaluation board for the MP2456, a high-voltage step-down regulator with a built-in power MOSFET.

MP2456 achieves a 0.5A peak-output current over a wide input supply range with excellent load and line regulation. Current-mode operation provides a fast transient response and eases loop stabilization.

The MP2456 is available in a TSOT23-6 package and requires a minimal number of readily-available external components.

The EV2456-J-00A is a fully assembled and tested evaluation board. It generates a +12V output voltage at load current up to 0.5A from a 15V to 50V input range.

ELECTRICAL SPECIFICATIONS

Parameter	Symbol	Value	Units
Input Voltage	V_{IN}	15 – 50	V
Output Voltage	V_{OUT}	12	V
Output Current	I_{OUT}	0.5	A

FEATURES

- Wide 4.5V-to-50V Operating Input Range
- 0.5A Peak Output Current
- Capable to Start Up with Big Output Capacitor
- Stable with Low-ESR Ceramic Output Capacitors
- Up to 90% Efficiency
- 0.1 μ A Shutdown Mode
- Fixed 1.2MHz Frequency
- Thermal Shutdown
- Cycle-by-Cycle Over-Current Protection
- Available in a TSOT23-6 Package

APPLICATIONS

- Power Meters
- Distributed Power Systems
- Battery Chargers
- Pre-Regulator for Linear Regulators
- WLED Drivers

All MPS parts are lead-free and adhere to the RoHS directive. For MPS green status, please visit MPS website under Quality Assurance. "MPS" and "The Future of Analog IC Technology" are Registered Trademarks of Monolithic Power Systems, Inc.

EV2456-J-00A EVALUATION BOARD

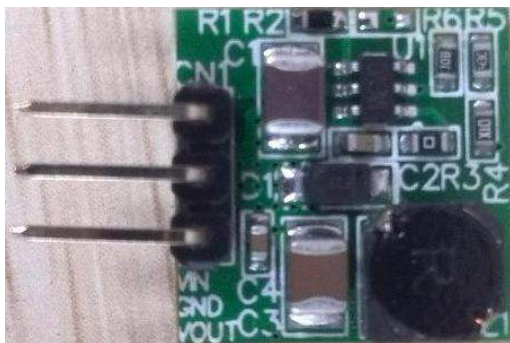

(L x W x H) 0.6" x 0.6" x 0.4"
(1.5cm x 1.5cm x 1.0cm)

Board Number	MPS IC Number
EV2456-J-00A	MP2456GJ

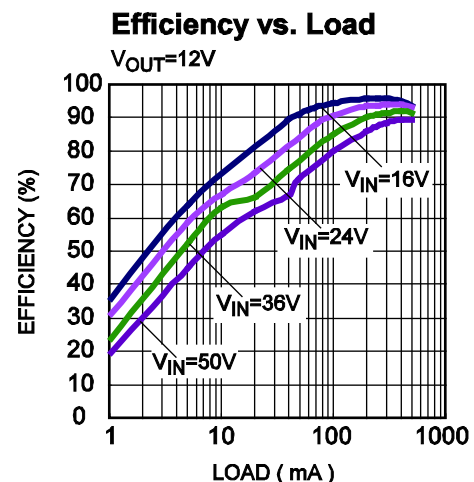

EVALUATION BOARD SCHEMATIC

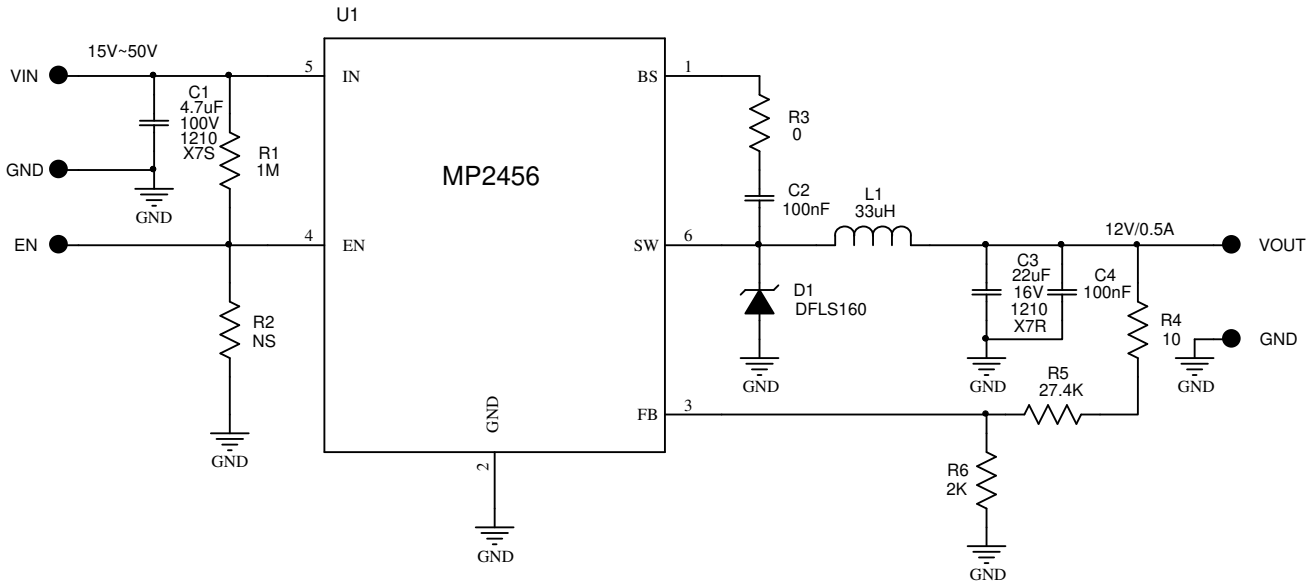

EV2456-J-00A BILL OF MATERIALS

Qty.	Ref	Value	Description	Package	Manufacture	Manufacture PN
1	C1	4.7µF	Ceramic Cap, X7S, 100V	1210	muRata	C3225X7S2A475K
2	C2,C4	0.1µF	Ceramic Cap, X7R, 16V	0603	muRata	GRM188R71C104KA01D
1	C3	10µF	Ceramic Cap, X7R, 16V	1210	muRata	GRM32DR71C106KA01L
1	CN1		Connector, 3pin, 2.54mm, right angle		any	
1	R1	1M	Film Res, 1%	0603	Yageo	RC0603FR-071ML
1	R2	NS				
1	R3	0R	Film Res, 5%	0603	Yageo	RC0603JR-070RL
1	R4	10	Film Res, 1%	0603	Yageo	RC0603FR-0710RL
1	R5	27.4k	Film Res, 1%	0603	Yageo	RC0603FR-07127K4L
1	R6	2k	Film Res, 1%	0603	Yageo	RC0603FR-072KL
1	D1	DFLS160	Diode Schottky, 60V, 1A	PowerDI123	Diodes Inc	DFLS160
1	L1	33µH	Inductor, 163mΩ, 1.2A	SMD	ABC	DM5028330ML
1	U1		Step-Down Regulator	TSOT23-6	MPS	MP2456GJ

EVB TEST RESULTS

Performance waveforms are tested on the evaluation board.

$V_{IN} = 24V$, $V_{OUT} = 12V$, $T_A = 25^\circ C$, unless otherwise noted.

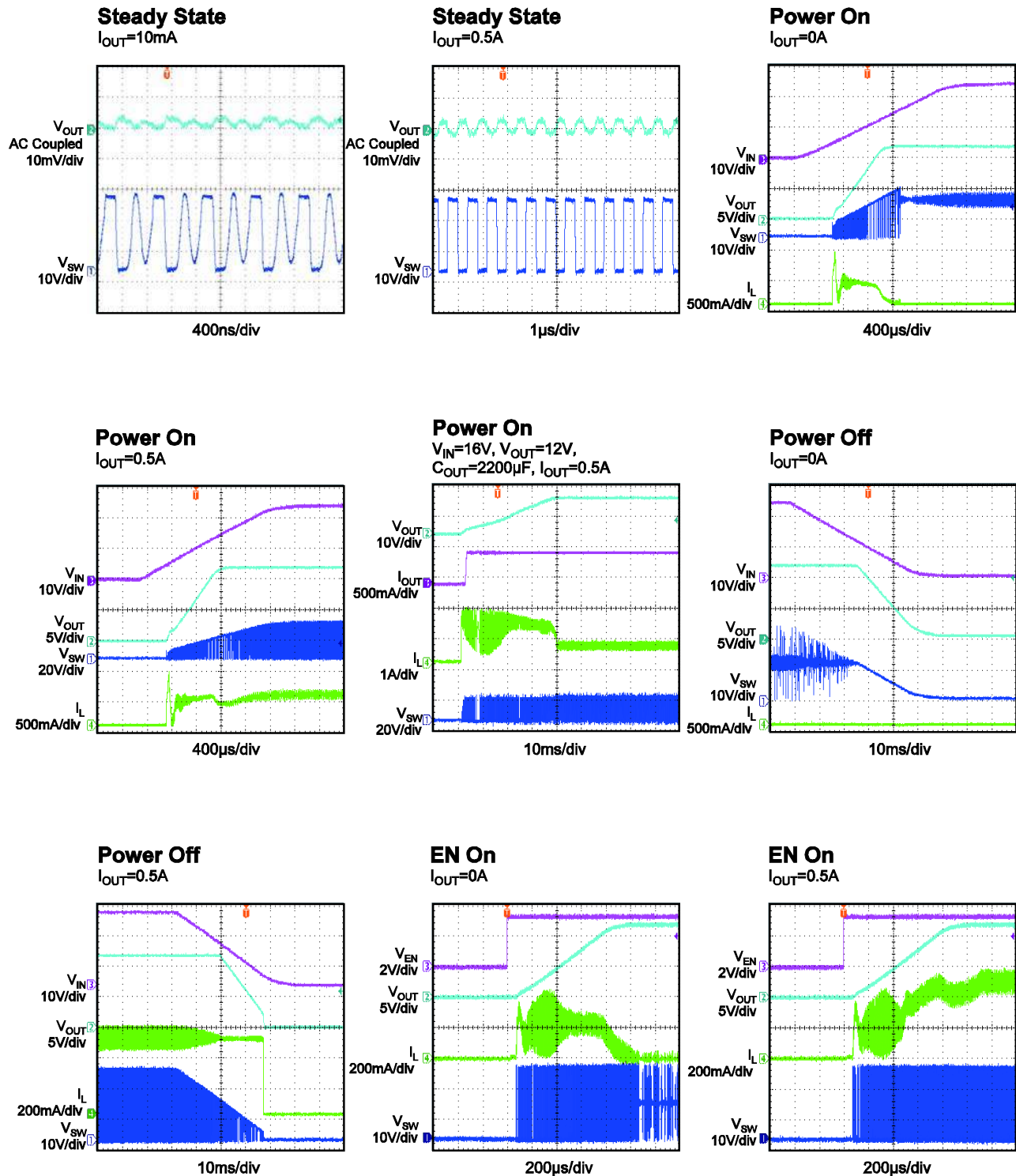

EVB TEST RESULTS *(continued)*

Performance waveforms are tested on the evaluation board.

$V_{IN} = 24V$, $V_{OUT} = 12V$, $T_A = 25^\circ C$, unless otherwise noted.

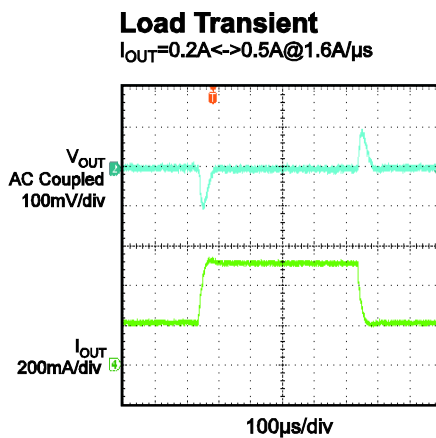
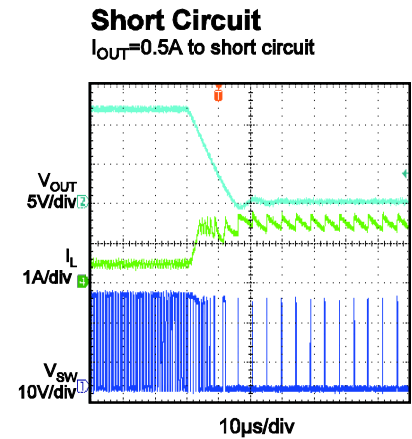
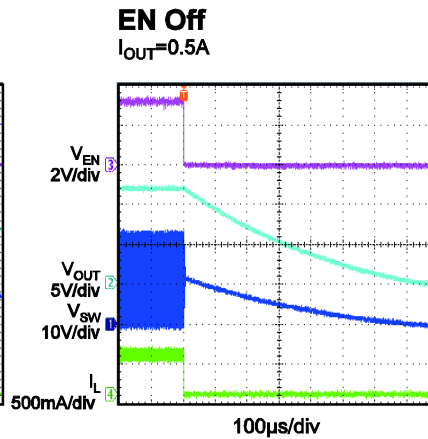
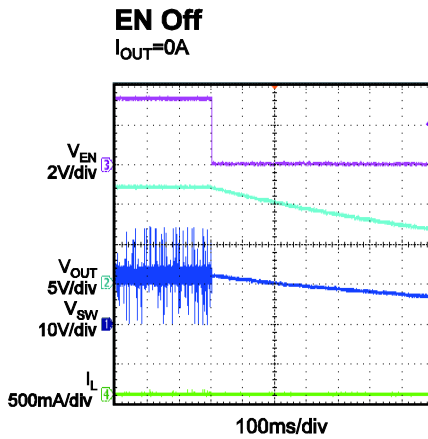

PRINTED CIRCUIT BOARD LAYOUT

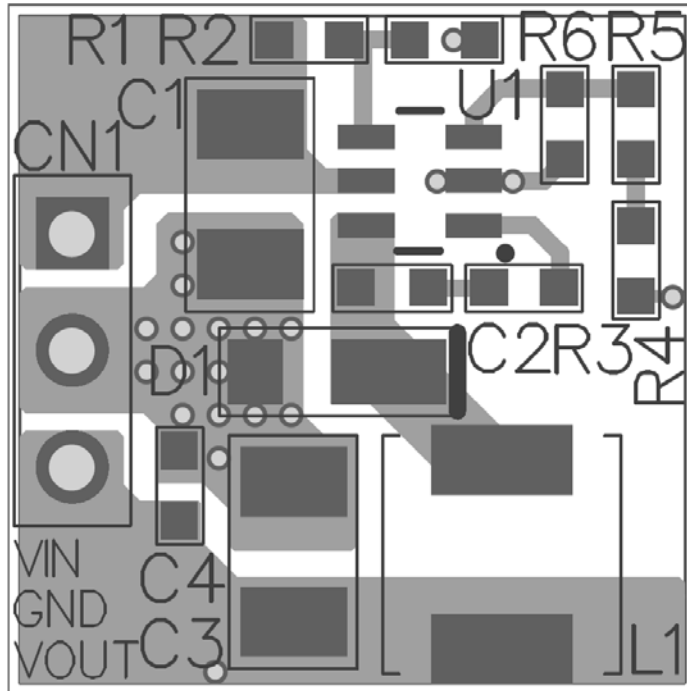

Figure 1—Top & Top Silk Layer

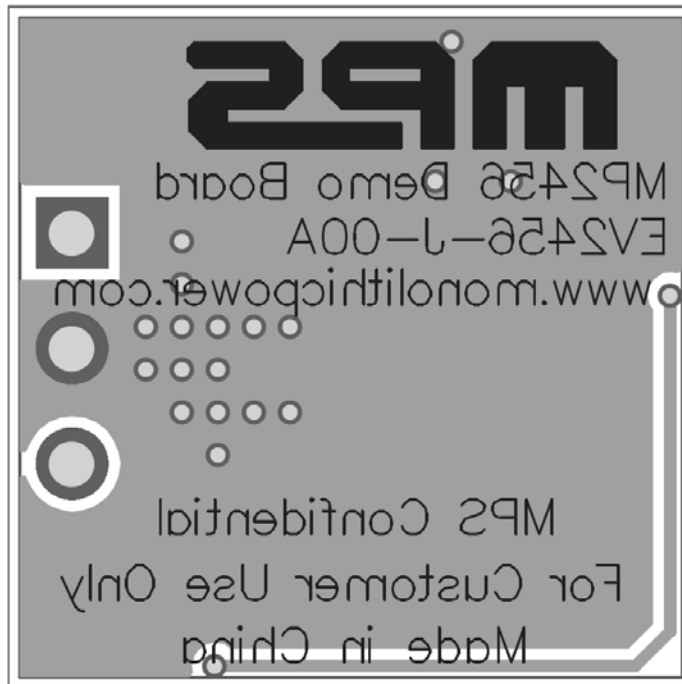

Figure 2—Bottom & Bottom Silk Layer

QUICK START GUIDE

1. Connect the positive and negative terminals of the load to the VOUT and GND pins, respectively.
2. Preset the power supply output between 15 and 50V, and then turn it off.
3. Connect the positive and negative terminals of the power supply output to the VIN and GND pins, respectively.
4. Turn the power supply on. The MP2456GJ will automatically startup.
5. To use the Enable function, apply a digital input to the EN pin. Drive EN higher than 1.35V to turn on the regulator, drive EN less than 1.17V to turn it off.
6. Use R5 and R6 to set the output voltage with $V_{FB} = 0.812V$. R5 can be calculated by
$$R5 = \left(\frac{V_{OUT}}{0.812V} - 1 \right) \times R6$$
 once R6 is determined.

NOTICE: The information in this document is subject to change without notice. Users should warrant and guarantee that third party Intellectual Property rights are not infringed upon when integrating MPS products into any application. MPS will not assume any legal responsibility for any said applications.