

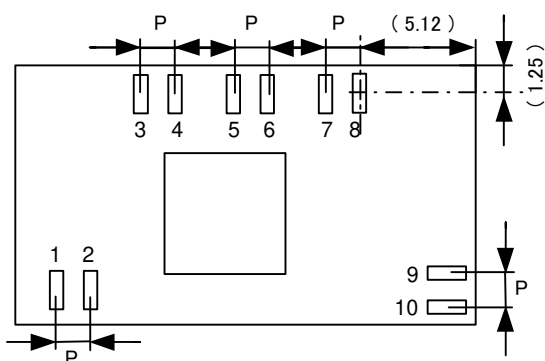
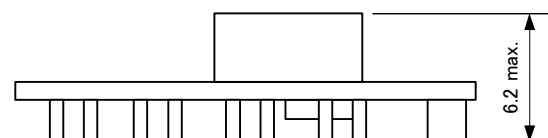
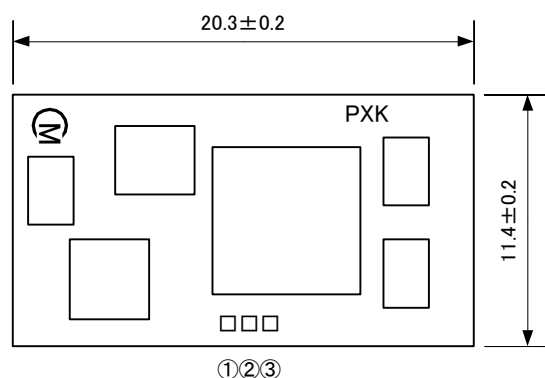
DC-DC Converter DATA Sheet

MPDTY413S

1. Features

- Up to 6A output current, non-isolated POL.
- Wide adjustable output voltage range by connecting external resistance (0.7525V to 5.5V).
- Wide operating temperature (-40 °C to +85 °C) .
- UVLO function / ON/OFF function, Over-current function and Over temperature function are built in.


2. Appearance, Dimensions



()...reference value

P=2.54 ±0.2mm

Marking

- (1) Pin No.1 Marking / MFG ID 
- (2) Parts No. P X K
- (3) Lot No. □ □ □
- ①②③

① Production Factory

② Production Year

③ Production Month (1,2,3,...9,O,N,D)

Flux may expand on PCB and attach onto the area where the marking is printed with laser.
In the case the marking become darker in color since flux is unreflecting.
It may be a little hard to read, however, the marking is not deleted nor blurred.

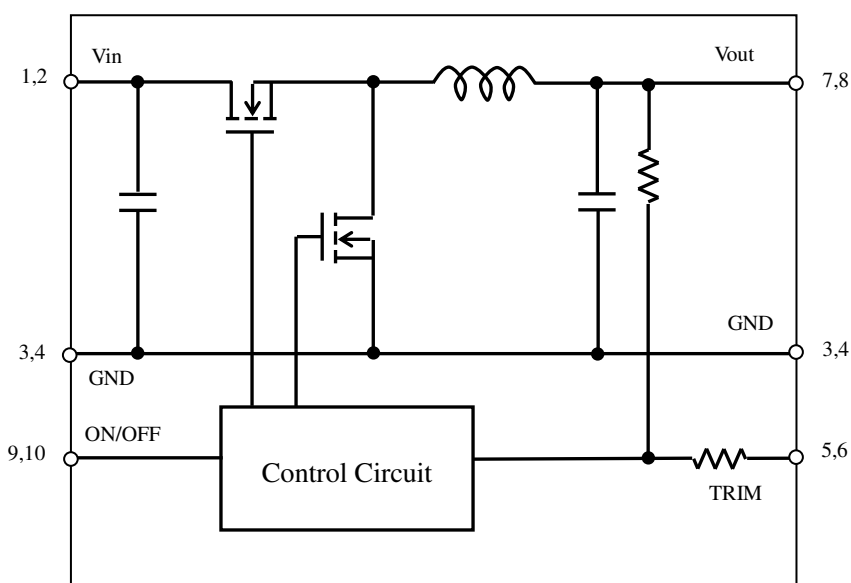
Note:

1. This datasheet is downloaded from the website of Murata Manufacturing co., ltd. Therefore, it's specifications are subject to change or our products in it may be discontinued without advance notice. Please check with our sales representatives or product engineers before ordering.
2. This datasheet has only typical specifications because there is no space for detailed specifications. Therefore, please approve our product specifications or transact the approval sheet for product specifications before ordering.

Pin Number and Function

Pin No.	Symbol	Function
1,2	Vin	Input Voltage
3,4	GND	GND
5,6	TRIM	Output Voltage Adjustment
7,8	Vout	Output Voltage
9,10	ON/OFF	Remote ON/OFF

3. Block Diagram



4. Environmental Conditions

4.1 Operating Temperature Range	-40°C ~ +85°C
4.2 Storage Temperature Range	-40°C ~ +85°C
4.3 Operating Humidity Range	20% ~ 85% (No water condenses in any cases.)
4.4 Storage Humidity Range	10% ~ 90% (No water condenses in any cases.)

5. Absolute Maximum Rating

Item	Unit	Absolute Rating	Remarks
Maximum Input Voltage	V	15V	
ON/OFF Pin Voltage	V	Vin+0.3V	

※No voltage, no matter how instantaneous, shall be applied beyond the absolute maximum voltage rating to this product. If you apply any voltage over this limit the product characteristics will deteriorate or the product itself will be destroyed. Even though it may continue operating for a while after the over-voltage event, its life will likely be shortened significantly. Reliability and life of the module may degrade similarly if the maximum operating voltage rating is continuously exceeded. This product is designed to operate within the maximum operating voltage rating specification.

 **Note:**

1. This datasheet is downloaded from the website of Murata Manufacturing co., ltd. Therefore, it's specifications are subject to change or our products in it may be discontinued without advance notice. Please check with our sales representatives or product engineers before ordering.
2. This datasheet has only typical specifications because there is no space for detailed specifications. Therefore, please approve our product specifications or transact the approval sheet for product specifications before ordering.

6. Characteristics

6. 1 Electrical Characteristics (Ta=25 °C)

Item	Symbol	Condition	Value			Unit	
			Min.	Typ.	Max.		
Input Voltage Range	Vin		10.0	12.0	14.0	V	
UVLO Threshold	UVLO		-	9.4	-	V	
Output Voltage Adjustable Range	Vout		0.7525	-	5.5	V	
Output Voltage Tolerance	Vo tol	Vin=10~14V Iout=0~6A	Vout=1.2V	1.164	1.2	1.236	V
			Vout=5.0V	4.85	5.0	5.15	
Output Current	Iout	See the thermal derating curve in section 6.2.	0	-	6	A	
Ripple Voltage	Vrpl	Vin =12V, Vout=2.5V, Iout=6A, BW=20MHz	-	35	70	mV(pp)	
Efficiency	EFF	Vin =12V, Iout=6A	Vout=2.5V	-	90	-	%
			Vout=3.3V	-	94	-	
Operating Frequency	Frq		-	400	-	kHz	
ON/OFF pin High Voltage	VIH	If ON/OFF pin is connected to Vin, the DC-DC converter shall be "OFF".	OFF	Vin-0.3	-	Vin	V
ON/OFF pin Low Voltage	VIL	If ON/OFF pin is connected to GND, the DC-DC Converter shall be "ON".	ON	0	-	0.3	V
Short Circuit Protection	SCP	If output is shorted to GND, DC-DC converter shall be operated in a hiccup mode. After the short circuit event has cleared, the output is automatically brought back into regulation.					
External Output Capacitor	Cout	When input voltage is ideal voltage source	47	-	1000	μF	
Output Rise Time	Tr	Vo=10%~90%	-	4	-	msec	
Rising Overshoot	Vover		-	-	+10	%	
Output Delay	Td	Vin High :ON/OFF High→Low Vo=10%	-	5	-	msec	

※Attention

If DC-DC converter with remote ON condition turns off by input voltage, the overshoot might be occurred at the time output voltage falls down.

S.R. of remote voltage

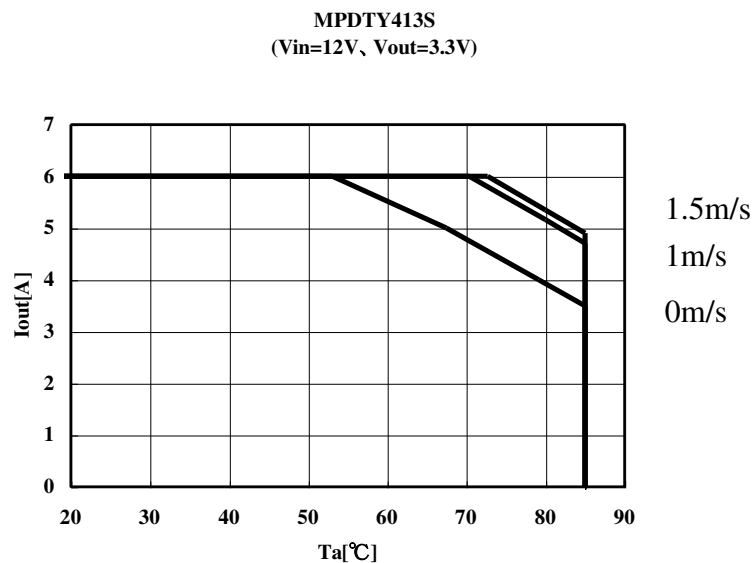
0.2V/ms more at remote ON

50V/ms more at remote OFF

⚠ Note:

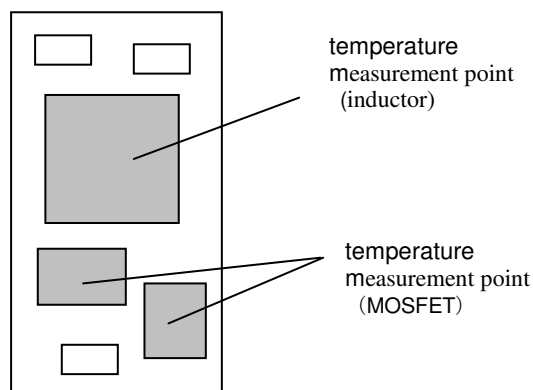
1. This datasheet is downloaded from the website of Murata Manufacturing co., ltd. Therefore, it's specifications are subject to change or our products in it may be discontinued without advance notice. Please check with our sales representatives or product engineers before ordering.
2. This datasheet has only typical specifications because there is no space for detailed specifications. Therefore, please approve our product specifications or transact the approval sheet for product specifications before ordering.

6. 2 Thermal Derating



When using this product at the ambient air temperature of 55°C more, it is used by the following temperature derating.

But when any other heat generating parts are close to this product, it may be over heated. Please confirm that the MOSFET temperature is below 120°C, the inductor temperature is below 106°C to secure operation reliability(see following fig).



 **Note:**

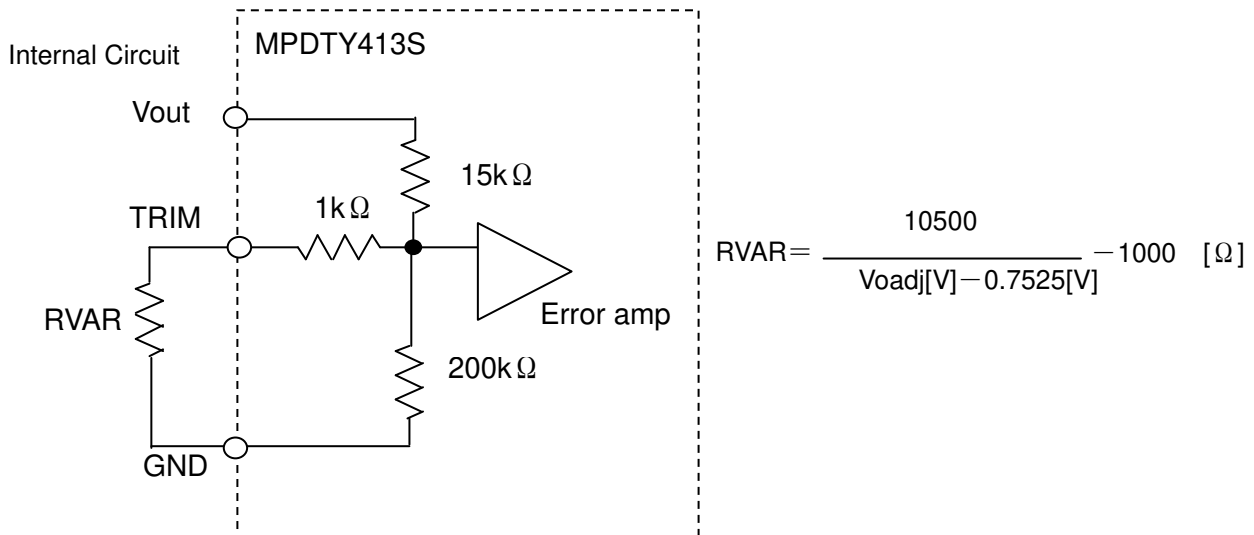
1. This datasheet is downloaded from the website of Murata Manufacturing co., ltd. Therefore, it's specifications are subject to change or our products in it may be discontinued without advance notice. Please check with our sales representatives or product engineers before ordering.
2. This datasheet has only typical specifications because there is no space for detailed specifications. Therefore, please approve our product specifications or transact the approval sheet for product specifications before orderina.

7. Operation information

7.1. Adjusting the Output Voltage

The output voltage can be adjusted from 0.7525V to 5.5V by connecting resistors between TRIM-pin(5,6Pin) to GND-pin.

The following equation gives the required external-resistor values to adjust the output voltage to the required Vout. It is highly recommended that evaluation of the characteristics of this DC-DC converter's operation under your board conditions be thoroughly conducted.



<RVAR Calculation Example>

Voadj [V]	Calculated RVAR[Ω]	RVAR example
5	1472	1.47 kΩ + 2Ω
3.3	3122	3kΩ + 120Ω
2.5	5009	4.99kΩ + 20Ω
1.8	9024	8.2kΩ + 820Ω
1.5	13047	13kΩ + 47Ω
1.2	22464	22kΩ + 470Ω
0.7525	∞	Open

7.2. Thermal shutdown

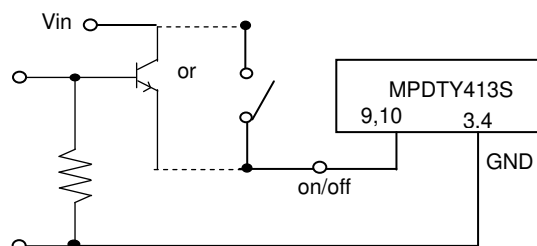
This DC-DC converter thermally shuts down when temperature of a control IC reaches to 165°C typically. (hysteresis : 20°C)

7.3. ON/OFF Control

Using the ON/OFF feature, the operation of this product can be disabled without removal of the input voltage. Sequencing of a power supply system and power-saving control can be easily achieved using this function.

ON/OFF Control Operation

When ON/OFF-pin(9,10pin) are left open Output Voltage =ON
 When ON/OFF-pin(9,10pin) is connected to Vin Output Voltage =OFF



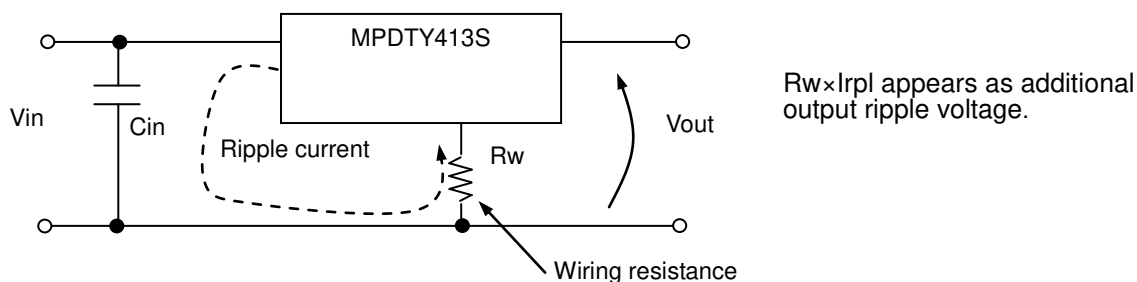
Note:

- This datasheet is downloaded from the website of Murata Manufacturing co., ltd. Therefore, it's specifications are subject to change or our products in it may be discontinued without advance notice. Please check with our sales representatives or product engineers before ordering.
- This datasheet has only typical specifications because there is no space for detailed specifications. Therefore, please approve our product specifications or transact the approval sheet for product specifications before orderina.

7.4. Input External capacitor

It is recommended to connect a low-impedance electrolytic capacitor of 22 μ F or more at Vin terminal. Smaller input capacitor may leads to an unstable operation of this product caused by input voltage fluctuation. Please check the proper operation of it on your product when smaller input capacitor is used.

Using ceramic capacitors as input capacitor may cause an increase of output voltage, because input ripple current flows through the external input capacitor and wiring resistance. This phenomenon is affected by the position of external capacitors, the value of external capacitors and voltage difference between Vin and Vout. Using low-impedance electrolytic capacitor will ease this problem. Please check the proper operation of it on your product when ceramic input capacitor is used.



7.5. Output External capacitor

Ceramic capacitors are recommended as output external capacitor. Using ceramic capacitors, small output variation and small ripple voltage are realized.

Output capacitor should be within 47 μ F to 1000 μ F. Output capacitor shall be placed near the output terminal. When using plural capacitors, please make sure to place a capacitor of at least 47 μ F near the output terminal, and place other capacitors near the load.

When using LC output filter, please make sure to place a capacitor of at least 47 μ F near the output terminal.

8. Reliability

8.1. Humidity

According to JIS-C-0022.

40 \pm 2 $^{\circ}$ C, 90 to 95%RH, 100 hours. Leave for 4 hours at room temperature.

No damage in appearance and no deviation from electrical characteristics (section 6.1.).

8.2. Temperature Cycles

Repeat cycle 5 times. Leave 2 hours at room temp.

No damage in appearance and no deviation from electrical characteristics (section 6.1.).

Step	Condition	Time
1	-40 $^{\circ}$ C \pm 3 $^{\circ}$ C	30 minutes
2	Room Temp.	5-10 minutes
3	+85 $^{\circ}$ C \pm 2 $^{\circ}$ C	30 minutes
4	Room Temp.	5-10 minutes

8.3. Vibration

10 to 55Hz, 1.5mm amplitude (1minute cycle), 1 hour for each of X, Y, Z directions.

No damage in appearance and no deviation from electrical characteristics (section 6.1.).

8.4. Mechanical Shock

20G, 1 time for each X, Y, Z directions.

No damage in appearance and no deviation from electrical characteristics (section 6.1.).

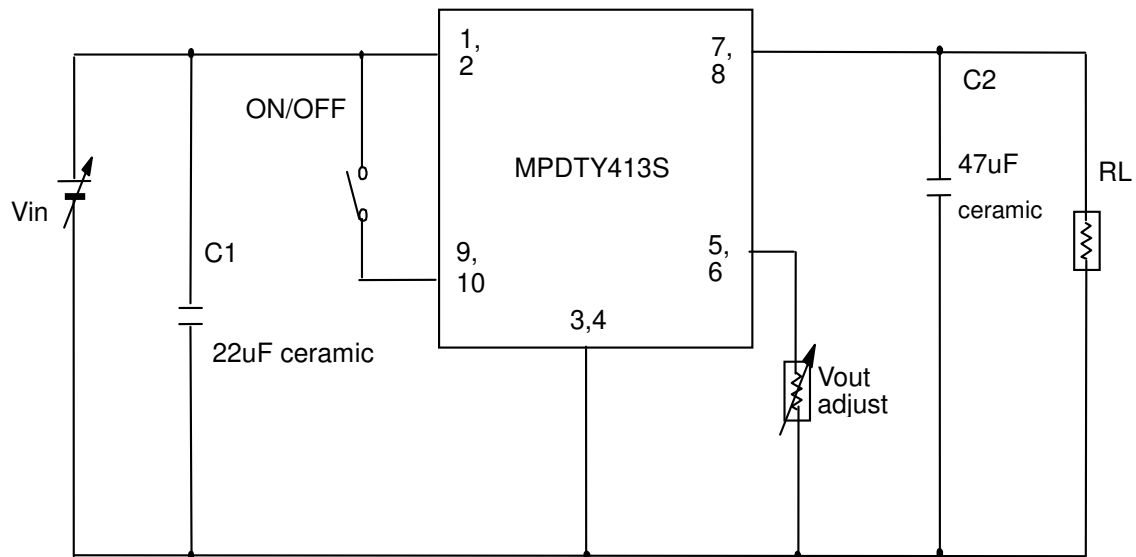
Note:

- This datasheet is downloaded from the website of Murata Manufacturing co., ltd. Therefore, it's specifications are subject to change or our products in it may be discontinued without advance notice. Please check with our sales representatives or product engineers before ordering.
- This datasheet has only typical specifications because there is no space for detailed specifications. Therefore, please approve our product specifications or transact the approval sheet for product specifications before ordering.

9. Test Circuit

In the following test circuit, the initial values under item 6.1. should be met.

9.1. General Measure Circuit



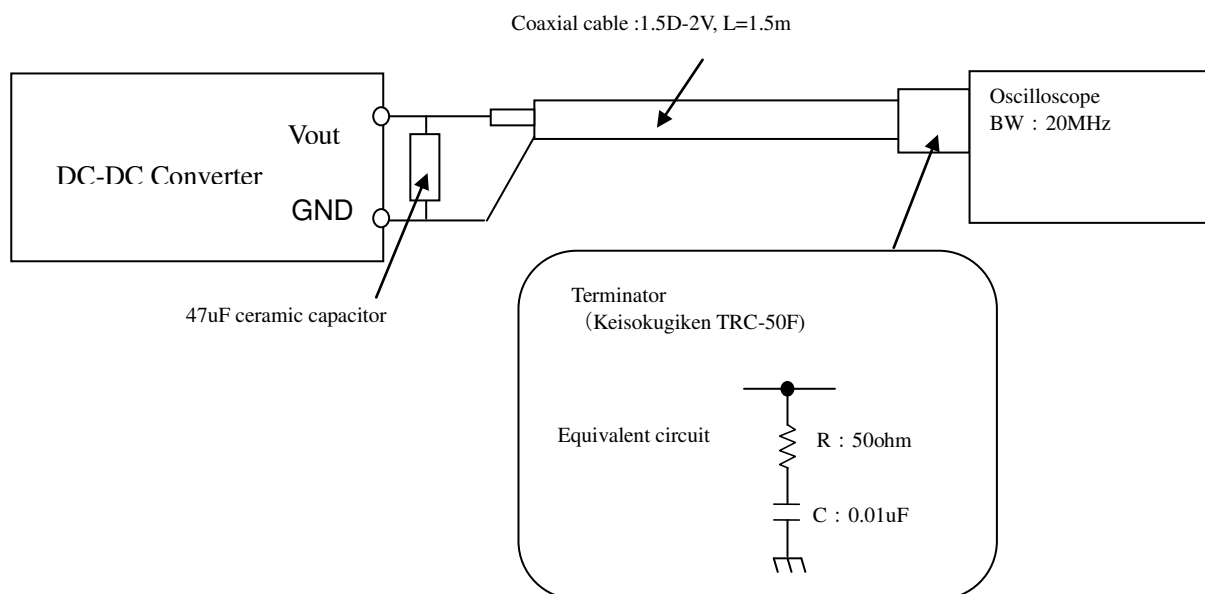
C1 : 22 μ F / 25V Ceramic Capacitor

C2 : 47 μ F / 10V Ceramic Capacitor

Please make sure to place C1 and C2 nearby input and output terminal of DC-DC converter.

9.2. Ripple Noise Measurement Circuit

Ripple Noise Measurement Circuit

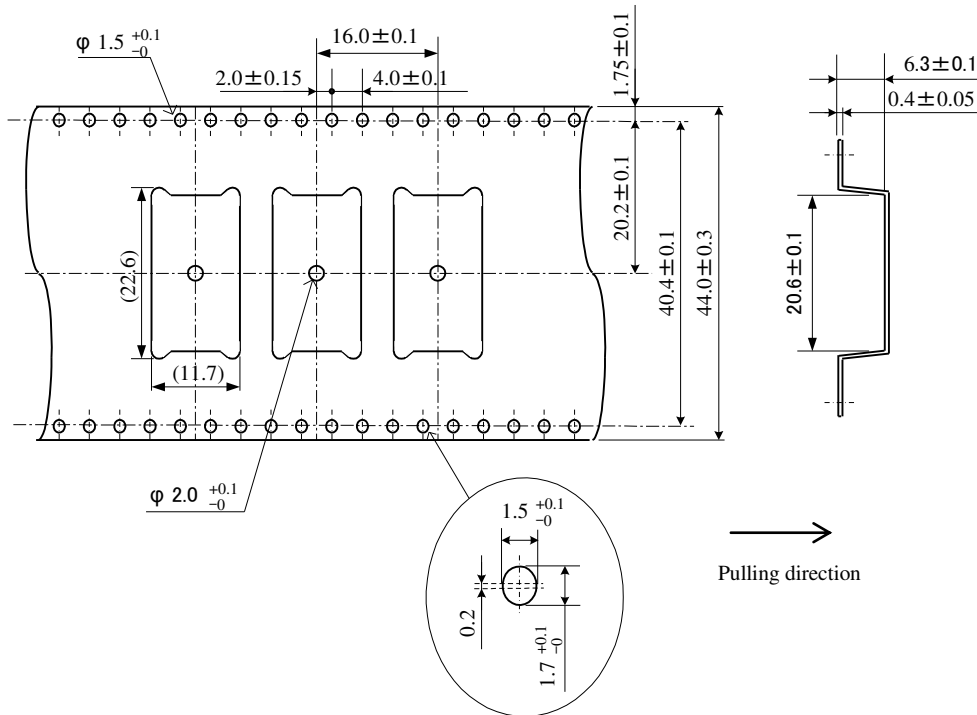


Note:

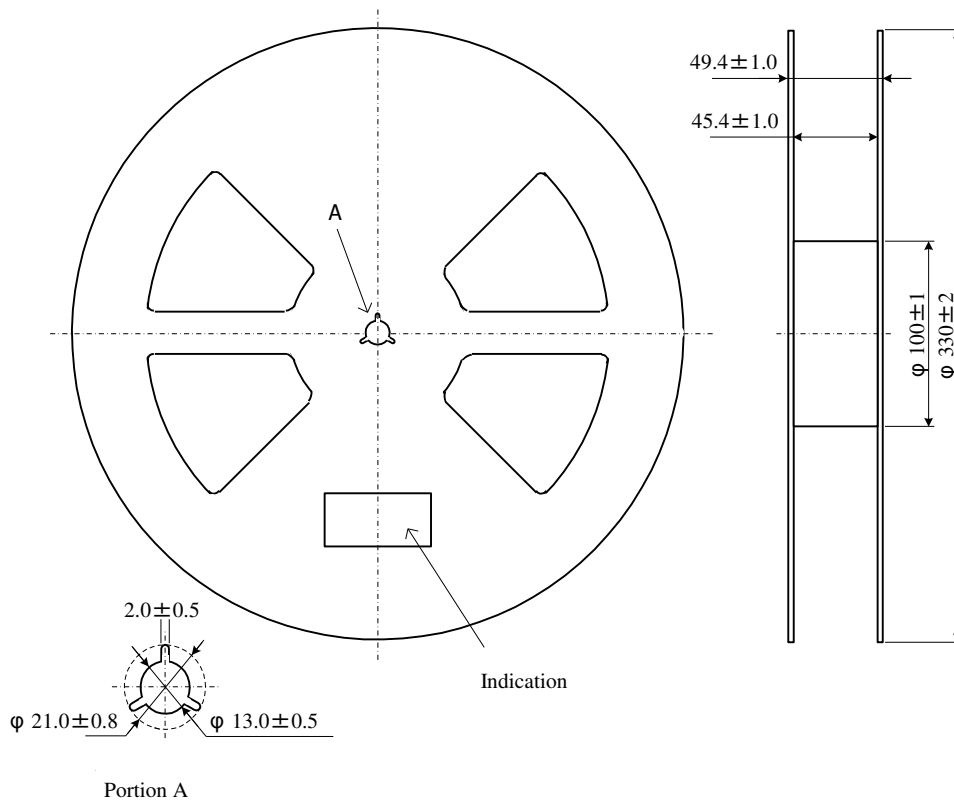
1. This datasheet is downloaded from the website of Murata Manufacturing co., ltd. Therefore, it's specifications are subject to change or our products in it may be discontinued without advance notice. Please check with our sales representatives or product engineers before ordering.
2. This datasheet has only typical specifications because there is no space for detailed specifications. Therefore, please approve our product specifications or transact the approval sheet for product specifications before ordering.

10. Packaging Specification

10.1. Emboss Tape Dimensions



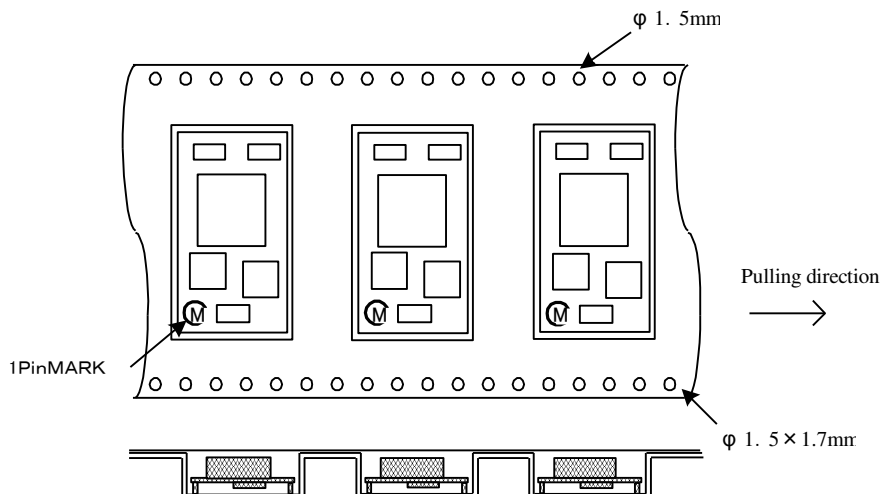
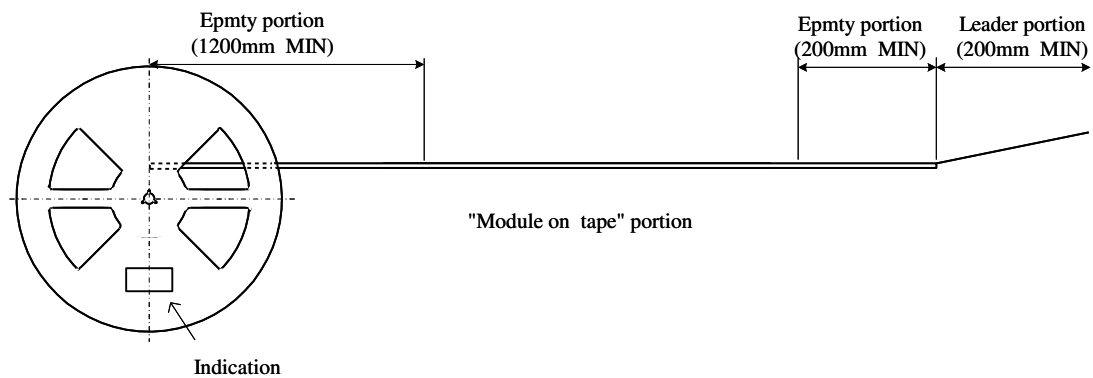
10.2. Real Dimensions



Note:

1. This datasheet is downloaded from the website of Murata Manufacturing co., ltd. Therefore, it's specifications are subject to change or our products in it may be discontinued without advance notice. Please check with our sales representatives or product engineers before ordering.
2. This datasheet has only typical specifications because there is no space for detailed specifications. Therefore, please approve our product specifications or transact the approval sheet for product specifications before orderina.

10.3. Taping Specification



The module is located such as inductor in upper side and terminal in lower side.

10.4. Note

1. The adhesive strength of the protective tape must be within 0.1-1.3N.
(In accordance with JIS 0806-3)
2. Each reel contains 300pcs.
3. The deficiency per reel is 0 piece.
4. The reel shows customer part number, Murata part number and quantity.
5. The color of reel is not designated.

11. Production factory

Komatsu Murata Mfg.Co., Ltd.
Kanazu Murata Mfg. Co., Ltd.
Wakura Murata Mfg. Co., Ltd.

Note:

1. This datasheet is downloaded from the website of Murata Manufacturing co., ltd. Therefore, it's specifications are subject to change or our products in it may be discontinued without advance notice. Please check with our sales representatives or product engineers before ordering.
2. This datasheet has only typical specifications because there is no space for detailed specifications. Therefore, please approve our product specifications or transact the approval sheet for product specifications before orderina.

12. Characteristics Data

12.1. $V_{out}=0.7525V$

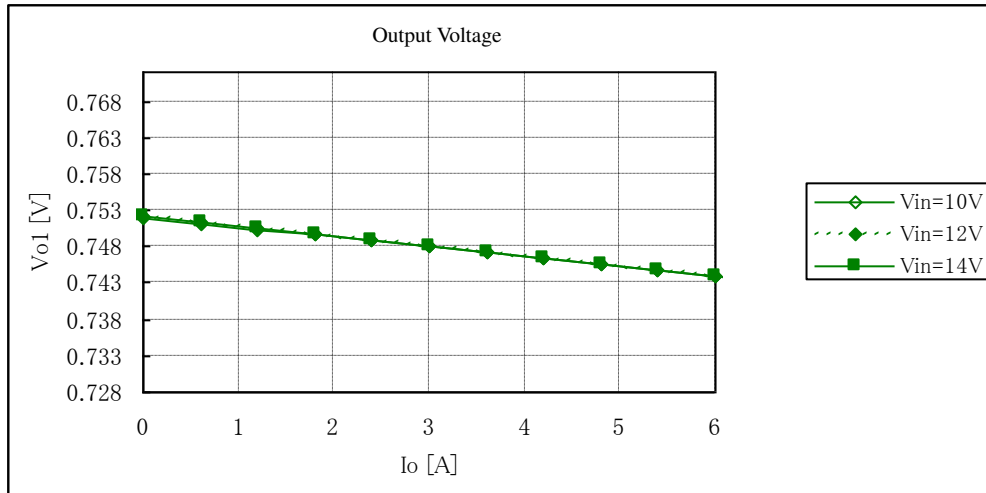


Fig. 12-1-1. Output Voltage v.s. Output Current

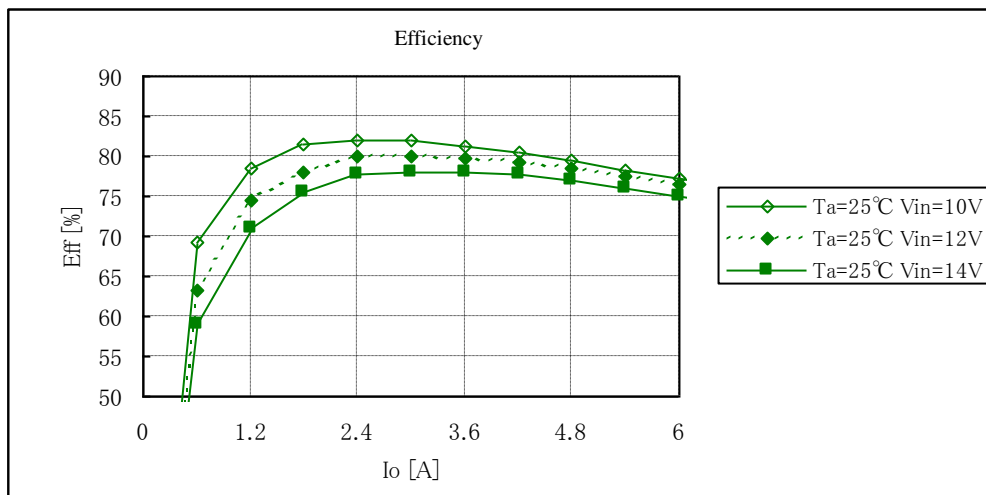


Fig. 12-1-2. Efficiency v. s. Output Current

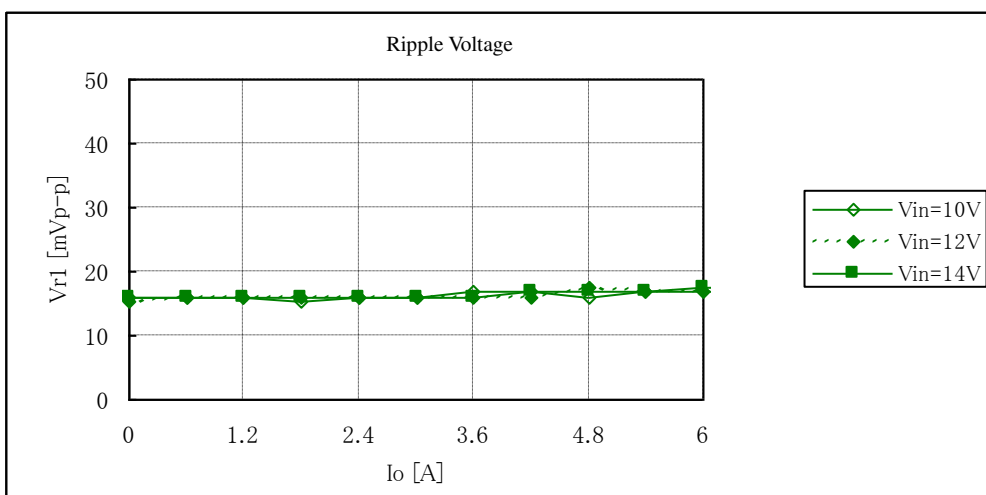


Fig. 12-1-3. Ripple Voltage v. s. Output Current

Note:

1. This datasheet is downloaded from the website of Murata Manufacturing co., ltd. Therefore, it's specifications are subject to change or our products in it may be discontinued without advance notice. Please check with our sales representatives or product engineers before ordering.
2. This datasheet has only typical specifications because there is no space for detailed specifications. Therefore, please approve our product specifications or transact the approval sheet for product specifications before orderina.

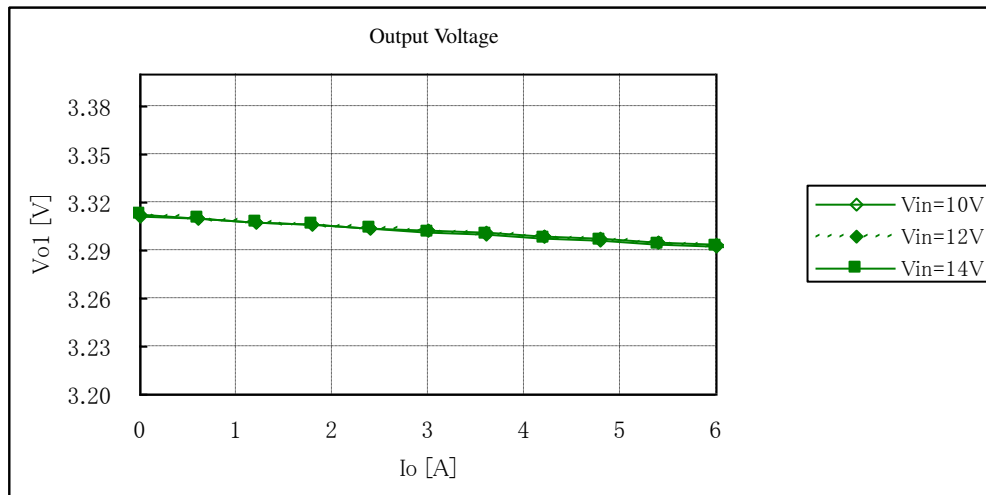
12.2. $V_{out}=3.3V$ 

Fig. 12-2-1. Output Voltage v.s. Output Current

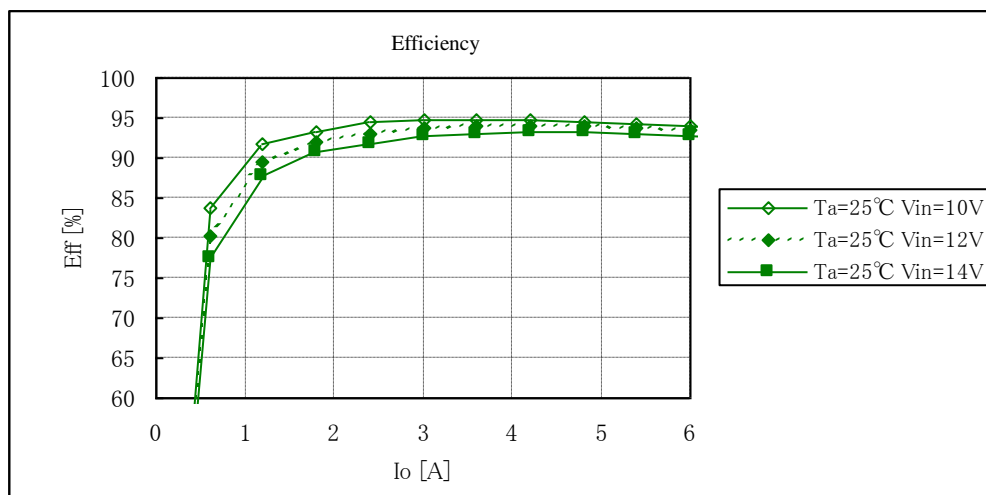


Fig. 12-2-2. Efficiency v. s. Output Current

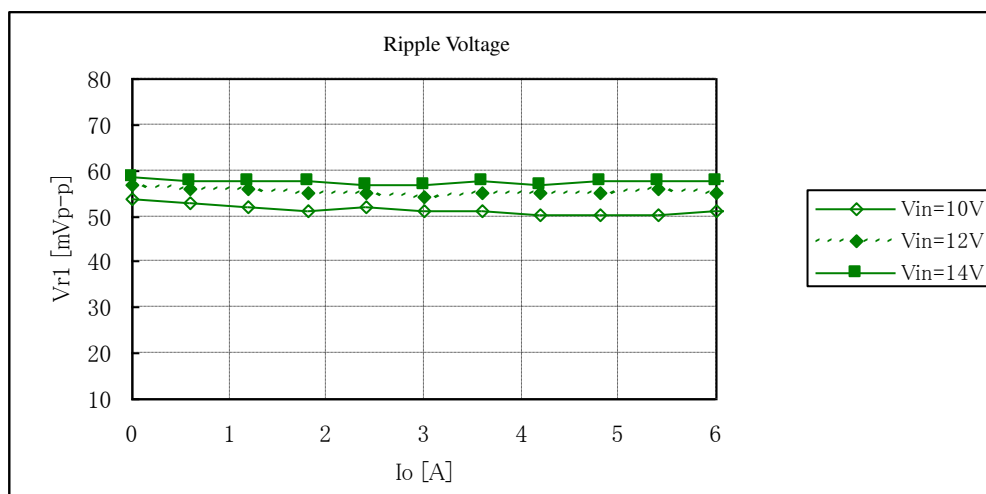


Fig. 12-2-3. Ripple Voltage v. s. Output Current

 **Note:**

1. This datasheet is downloaded from the website of Murata Manufacturing co., ltd. Therefore, it's specifications are subject to change or our products in it may be discontinued without advance notice. Please check with our sales representatives or product engineers before ordering.
2. This datasheet has only typical specifications because there is no space for detailed specifications. Therefore, please approve our product specifications or transact the approval sheet for product specifications before orderina.

12.3. Vout=5.5V

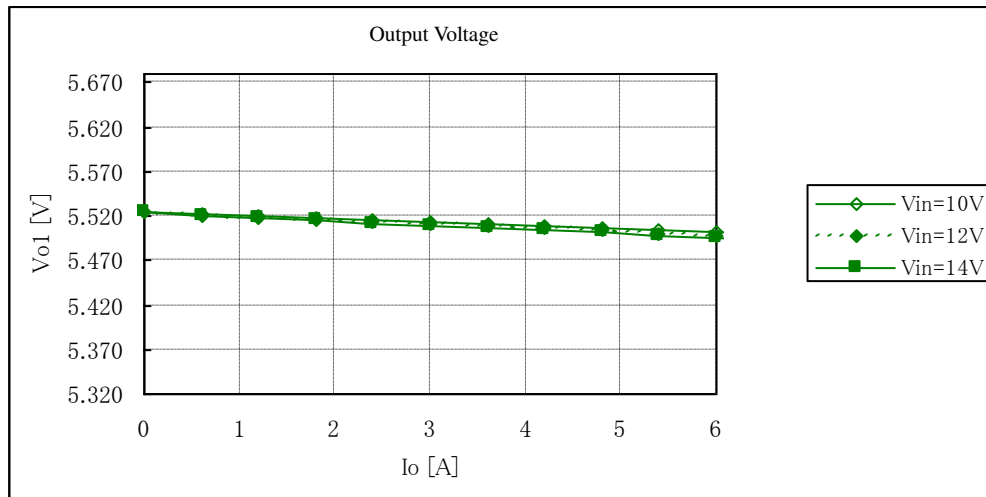


Fig. 12-3-1. Output Voltage v.s. Output Current

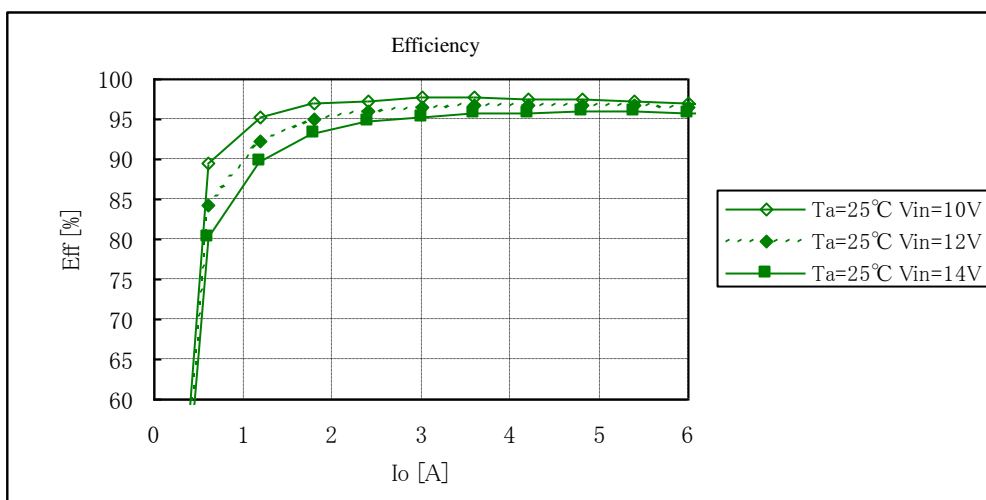


Fig. 12-3-2. Efficiency v. s. Output Current

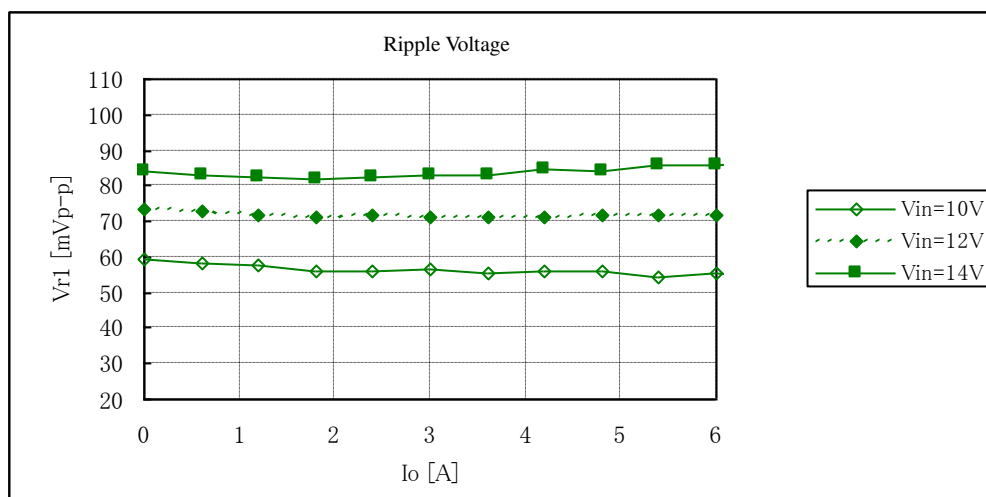


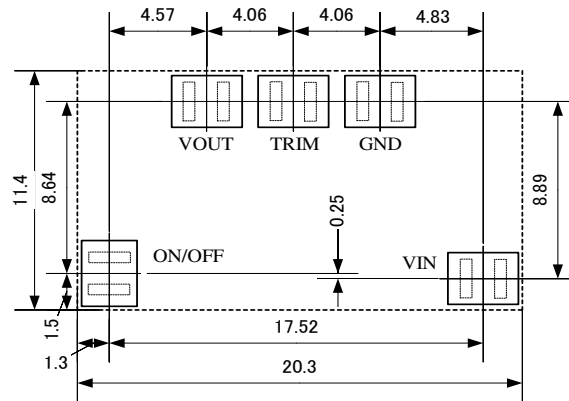
Fig. 12-3-3. Ripple Voltage v. s. Output Current

 **Note:**

1. This datasheet is downloaded from the website of Murata Manufacturing co., ltd. Therefore, it's specifications are subject to change or our products in it may be discontinued without advance notice. Please check with our sales representatives or product engineers before ordering.
2. This datasheet has only typical specifications because there is no space for detailed specifications. Therefore, please approve our product specifications or transact the approval sheet for product specifications before ordering.

13. Mounting Condition

13.1. PCB Land Pattern Recommendation



Recommendable Land Size 3.3mm × 2.2 mm

13.2. Recommended Soldering Conditions

Reflow Soldering

This product is RoHS compliant. The following profile is recommended for the reflow of this product using Pb-free solder paste (Sn-Ag-Cu).

Method : Full convection reflow soldering

Reflow Soldering Profile

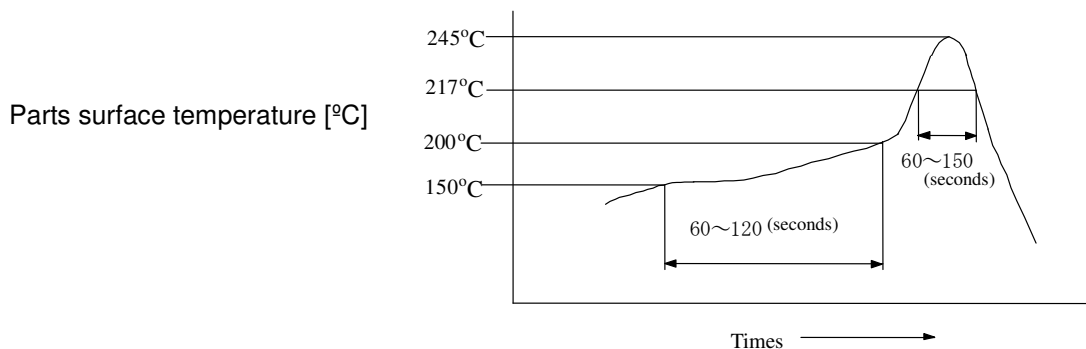
JEDEC IPC/JEDEC J-STD-020D

Table 5-2 Classification Reflow Profile

Pb-Free Assembly Large Body

Profile details

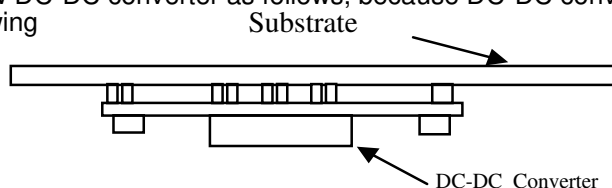
Soldering temperature	: 245°C+0/-5°C
Soldering time	: 30 seconds, 240 to 245°C
Heating time	: 60 to 150 seconds, over 217°C
Preheating time	: 60 to 120 seconds, 150 to 200°C
Programming rate	: 3°C/ sec. Max., 217 to 245°C
Descending rate	: 6°C/ sec. Max.
Total soldering time	: 8 minutes Max., 25 to 245°C
Times	: 1 time



※Do not vibrate for the products on reflow.

Please need to take care temperature control because mounted parts may come off if the product are left under the high temperature.

Do not reflow DC-DC converter as follows, because DC-DC converter may fall down from a substrate during reflowing

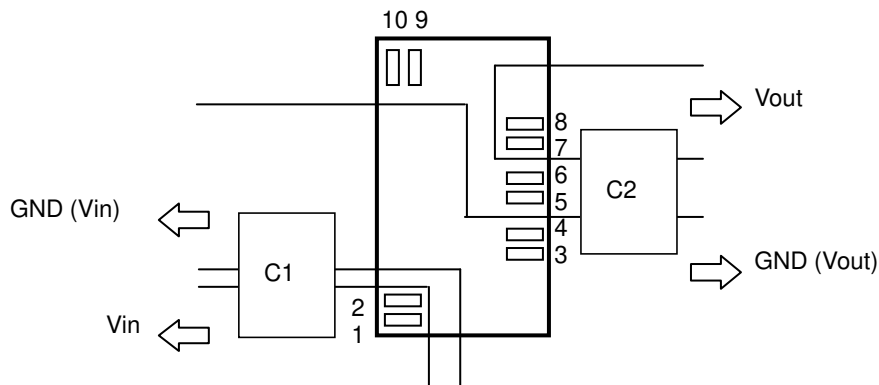


Note:

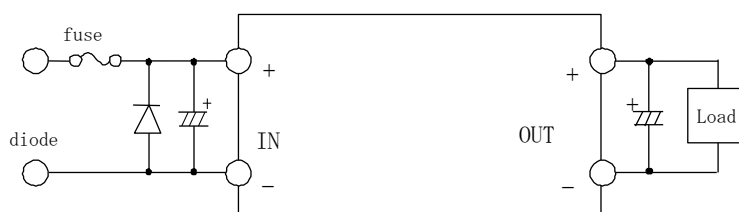
1. This datasheet is downloaded from the website of Murata Manufacturing co., ltd. Therefore, it's specifications are subject to change or our products in it may be discontinued without advance notice. Please check with our sales representatives or product engineers before ordering.
2. This datasheet has only typical specifications because there is no space for detailed specifications. Therefore, please approve our product specifications or transact the approval sheet for product specifications before ordering.

14. Notice

14. 1. Both input-side and output side, please make the wiring loop between plus and minus as small as possible. The influence of a leakage inductance can be reduced.
14. 2. Please make the power line pattern as wide and short as possible. The Following figure is an example of recommendable PCB design.



14. 3. This product should not be operated in parallel or in series.
14. 4. Please do not use a connector or a socket to connect this product to your product. The electric characteristics may be deteriorated by the influence of contact resistance.
14. 5. Be sure to provide an appropriate fail-safe function on your product to prevent secondary damage that may be caused due to abnormal functional or failure of this product.
14. 6. Inrush current protection is not a feature of this product.
14. 7. Please connect the input terminals with the correct polarity. If an error in polarity connection is made this product may be damaged. If this product is damaged internally, an elevated input current may flow, and so this product may exhibit an abnormal temperature rise, or your product may be damaged. Please add a diode and fuse per the following diagram to protect them.



※Please select diode and fuse after confirming the operation of your product.

14. 8. Cleaning

Please use no-cleaning type flux and do not wash this product.

14.9. Storage

14.9.1. Please store the products in room where the temperature/humidity is stable and direct sunlight cannot come in, and use the products within 6 months after delivery.

Please avoid damp and heat or such places where the temperature greatly changes, as water may condense on this product, and the quality of characteristics may be reduced, and/or be the solderability may be degraded.

If this product needs to be stored for a long time (more than 1 year), this product may be degraded in solderability and/or corroded. Please test the solderability of this product regularly. Baking before reflow process is unnecessary to store the products under 30°C, 60%RH or less up to 6 months.

In case the storage condition is over above mentioned, if these are unpacked condition, please bake them at 125°C ± 5°C/24hour. If these are packed in a tape, please bake them before soldering at 60°C ± 5°C /168hour.

14.9.2. Please do not store this product in places such as :

A dusty place, a place exposed directly to sea breeze, or in an atmosphere containing corrosive gas (Cl₂, NH₃, SO₂, NO_x and so on).

 **Note:**

- This datasheet is downloaded from the website of Murata Manufacturing co., Ltd. Therefore, it's specifications are subject to change or our products in it may be discontinued without advance notice. Please check with our sales representatives or product engineers before ordering.
- This datasheet has only typical specifications because there is no space for detailed specifications. Therefore, please approve our product specifications or transact the approval sheet for product specifications before ordering.

14. 10 Operational Environment and Operational Conditions

14. 10. 1. Operational Environment

This product is not water-, chemical- or corrosion-proof.

In order to prevent leakage of electricity and abnormal temperature rise of the product, do not operate under the following environmental conditions:

- (1) An atmosphere containing corrosive gas (Cl₂, NH₃, SO₂, NO_x and so on)
- (2) A high-dust environment
- (3) Under the exposure of direct sunlight
- (4) A location where the likelihood of exposure to water or water condensation exists.
- (5) A location exposed to ocean air
- (6) Any locations similar to the above

14. 10. 2. Operational Conditions

Please use this product within specified values (power supply, temperature, input, output and load condition, and so on). If the product is exposed to conditions outside of the specified values reliability of the product may be adversely effected.

14. 10. 3. Note prior to use

Diminished reliability and/ or failure may result if the product is exposed to a high-level static charge, over-rated voltage or reverse voltage. Please avoid the following conditions be avoided prior to use of the product:

- (1) Supply of power outside of rated values (see section 8)
- (2) Supply of reverse power or inadequate connection of a 0 V(DC)line
- (3) Electrostatic discharge from production line and/ or operator
- (4) Electrification of the product from electrostatic induction
- (5) Excessive mechanical shock

14. 11. Transportation

Murata recommends that when transporting this product, it be packed so as to avoid damage by mechanical

vibration or exposure to adverse conditions such as ocean air, high humidity. It is additionally recommended

that appropriate instructions and guidelines be communicated to carriers to prevent exposure to these same conditions.

Note

1. Murata recommends that customers ensure that the evaluation and testing of these devices are completed with this product actually assembled on their product.
2. Please contact our main sales office or nearby sales office before using our products for the applications listed below which require especially high reliability for the prevention of defects which might directly cause damage to the third party's life, body or property or this products for any other applications that described in the above.
 - ① Aircraft equipment
 - ② Aerospace equipment
 - ③ Undersea equipment
 - ④ Power plant control equipment
 - ⑤ Medical equipment
 - ⑥ Transportation equipment (vehicles, trains, ships, etc.)
 - ⑦ Traffic signal equipment
 - ⑧ Disaster prevention /crime prevention equipment
 - ⑨ Data-processing equipment
 - ⑩ Application of similar complexity and/or reliability requirements to the applications listed in the above.
3. This DATA Sheet is indicated in March. 2009. About the written contents, since changing without a preliminary announcement for improvement and supply are sometimes stopped, please confirm in case of ordering.
If written contents are unknown, please ask to our main sales office or nearby sales office.

Note:

1. This datasheet is downloaded from the website of Murata Manufacturing co., ltd. Therefore, it's specifications are subject to change or our products in it may be discontinued without advance notice. Please check with our sales representatives or product engineers before ordering.
2. This datasheet has only typical specifications because there is no space for detailed specifications. Therefore, please approve our product specifications or transact the approval sheet for product specifications before ordering.