

Evaluating the **AD5290** Compact, 30 V/±15 V, 256-Position Digital Potentiometer

FEATURES

Full featured evaluation board in conjunction with high voltage digital potentiometer motherboard
(**EVAL-MB-HV-SDZ**)

PC control via **SDP-B** or **SDP-S**

PC software for control

EVALUATION KIT CONTENTS

EVAL-AD5290DBZ board

EVAL-MB-HV-SDZ motherboard

CD containing

Self installing software that allows users to control the EVAL-AD5290DBZ and exercise all functions of the device

Electronic version of the **AD5290** data sheet

Electronic version of the EVAL-AD5290DBZ user guide

GENERAL DESCRIPTION

This user guide describes the full featured EVAL-AD5290DBZ board for evaluating the **AD5290** digital potentiometer. The **AD5290** is a single-channel, 256-position with high voltage, high performance, and compact digital potentiometers. The **AD5290** is capable of operating at high voltages, supporting both dual supply (±10 V to ±15 V) and single supply (20 V to 30 V) operation.

The **AD5290** uses a versatile 3-wire serial interface that operates at clock rates of up to 4 MHz and is compatible with the standard serial peripheral interface (SPI).

The EVAL-AD5290DBZ incorporates an internal power supply from the USB and allows an external power supply for the logic voltage levels. The EVAL-AD5290DBZ can operate in single supply and dual supply modes, and incorporates an output buffer.

Complete specifications for the **AD5290** can be found in the **AD5290** data sheet available from Analog Devices, Inc., and must be consulted in conjunction with this user guide when using the evaluation board.

EVAL-AD5290DBZ WITH **EVAL-MB-HV-SDZ** MOTHERBOARD PHOTOGRAPH

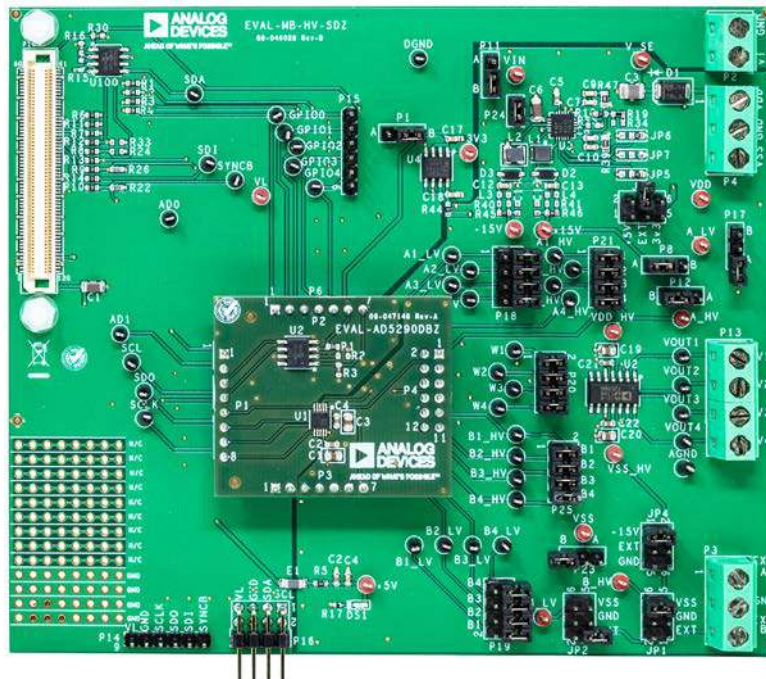

Figure 1.

TABLE OF CONTENTS

Features	1	Evaluation Board Software.....	5
Evaluation Kit Contents.....	1	Installing the Software	5
General Description	1	Evaluation Board Schematics and Artwork.....	6
EVAL-AD5290DBZ with EVAL-MB-HV-SDZ Motherboard		Motherboard	6
Photograph	1	Daughter Board	12
Revision History	2	Ordering Information.....	14
Evaluation Board Hardware	3	Bill of Materials.....	14
Power Supplies	3		

REVISION HISTORY

1/2020—Revision 0: Initial Version

EVALUATION BOARD HARDWARE

POWER SUPPLIES

The EVAL-MB-HV-SDZ motherboard supports use of single and dual power supplies. The EVAL-MB-HV-SDZ motherboard can also be used to evaluate a low voltage digital potentiometer using the P9 connector.

The EVAL-AD5290DBZ evaluation board can be powered either from the system demonstration platform (SDP) port or

externally by the P4 connector and P2 connector, as described in Table 1.

Link Options

Several link and switch options are incorporated in the EVAL-MB-HV-SDZ motherboard and must be set up before powering up the EVAL-MB-HV-SDZ. The functions of these link options and the default options are described in detail in Table 2.

Table 1. Maximum and Minimum Voltages of the Connectors

Connector No.	Label	Voltage
P4-1	VDD	Analog positive power supply, V_{DD} . Single supply from 20 V to 30 V. Dual supply from 10 V to 15 V. Dual supply through the ADP5071, 5 V.
P4-2	GND	Analog ground.
P4-3	VSS	Analog negative power supply, V_{SS} . Single supply operation of 0 V. Dual supply from -10 V to -15 V.
P2-1	VL	Digital supply, from 2.7 V to 5 V.
P2-2	GND	Digital ground.

Table 2. Link Functions

Link No.	Label/Link Function	Default Position	Options
P11	VIN	B	Selects the power supply, V_{IN} , for the ADP5071 A: V_{SINGLE} (derived from V_{DD_EXT} , external supply from the P4 connector) B: +5 V (5 V from SDP-B or SDP-S)
P1	VL	B	Selects the logic power supply, V_{LOGIC} A: VL_EXT (external supply from the P2 connector) B: VL3V3 (3.3 V from SDP-B or SDP-S)
JP3	VDD	Not inserted	Selects the low voltage positive power supply, V_{DD_LV} A: +5 V (5 V from SDP-B or SDP-S) B: V_{DD_EXT} (external supply from the P4 connector) C: VL3V3 (3.3 V from SDP-B or SDP-S)
P23	VSS	Not inserted	Selects the low voltage negative power supply, V_{SS_LV} A: V_{SS_EXT} (external supply from the P4 connector) B: AGND
P8	VDD_HV	A	Selects the high voltage positive power supply, V_{DD_HV} A: 15 V (+15 V from ADP5071) B: V_{DD_EXT} (external supply from the P4 connector)
JP4	VSS_HV	A	Selects the high voltage negative power supply, V_{SS_HV} A: -15 V (-15 V from ADP5071) B: V_{SS_EXT} (external supply from the P4 connector) C: AGND
P17	A_LV	Not inserted	Selects the voltage at Terminal A for the low voltage digital potentiometer A: A_EXT (external supply from the P3 connector) B: VDD
JP2	B_LV	Not inserted	Selects the voltage at Terminal B for the low voltage digital potentiometer A: VSS B: AGND C: B_EXT (external supply from the P3 connector)
P12	A_HV	B	Selects the voltage at Terminal A for the high voltage digital potentiometer A: A_EXT (external supply from the P3 connector) B: V_{DD_HV}

Link No.	Label/Link Function	Default Position	Options
JP1	B_HV	A	Selects the voltage at Terminal B for the high voltage digital potentiometer A: VSS_HV B: AGND C: B_EXT (external supply from the P3 connector)
P24	Supply for ADP5071	Inserted	Connects V _{IN} to the supply terminal of ADP5071 .
P21	A_HV channel links A1_HV A2_HV A3_HV A4_HV	Inserted Inserted Inserted Inserted	Connects Terminal A1 to A_HV Connects Terminal A2 to A_HV Connects Terminal A3 to A_HV Connects Terminal A4 to A_HV
P18	A_LV channel links A1_LV A2_LV A3_LV A4_LV	Not inserted Not inserted Not inserted Not inserted	Connects Terminal A1 to A_LV Connects Terminal A2 to A_LV Connects Terminal A3 to A_LV Connects Terminal A4 to A_LV
P19	B_LV channel links B1_LV B2_LV B3_LV B4_LV	Not inserted Not inserted Not inserted Not inserted	Connects Terminal B1 to B_LV Connects Terminal B2 to B_LV Connects Terminal B3 to B_LV Connects Terminal B4 to B_LV
P25	B_HV channel links B1_HV B2_HV B3_HV B4_hV	Inserted Inserted Inserted Inserted	Connects Terminal B1 to B_HV Connects Terminal B2 to B_HV Connects Terminal B3 to B_HV Connects Terminal B4 to B_HV
P20	Buffer connector W1_BUF W2_BUF W3_BUF W4_BUF	Inserted Inserted Inserted Inserted	Connects Terminal W1 to an output buffer Connects Terminal W2 to an output buffer Connects Terminal W3 to an output buffer Connects Terminal W4 to an output buffer

EVALUATION BOARD SOFTWARE

INSTALLING THE SOFTWARE

The EVAL-AD5290DBZ kit includes a CD containing the evaluation board software. The software is compatible with Windows® 7, Windows 8, and Windows 10.

Install the software before connecting the SDP board to the USB port of the PC so that the **SDP-B** or **SDP-S** board is recognized when it is connected to the PC.

To install the software, perform the following steps:

1. Start the Windows operating system and insert the CD into the CD ROM drive.
2. The installation software opens automatically. If it does not open automatically, run the **setup.exe** file from the CD.
3. After the installation is complete, power up the evaluation board as described in the Power Supplies section.
4. Connect the EVAL-AD5290DBZ and **EVAL-MB-HV-SDZ** to the **SDP-B** or **SDP-S** board, and then connect the **SDP-B** or **SDP-S** board to the PC using the USB cable included with the **SDP-B** or **SDP-S** board.
5. When the software detects the evaluation board, follow the instructions that appear to complete installation.

To run the program, perform the following steps:

1. Select **Start > All Programs > Analog Devices > AD5290 > AD5290 Eval Board**. To uninstall the program, select **Start > Control Panel > Add or Remove Programs > AD5290 Eval Board**.
2. If the **SDP-B** or **SDP-S** board is not connected to the USB port when the software is launched, a connectivity error displays (see Figure 2). Connect the EVAL-AD5290DBZ to the USB port of the PC, wait a few seconds, click **Rescan**, and follow the instructions.

The main window of the EVAL-AD5290DBZ software then opens, as shown in Figure 3.



Figure 2. Connectivity Error Window

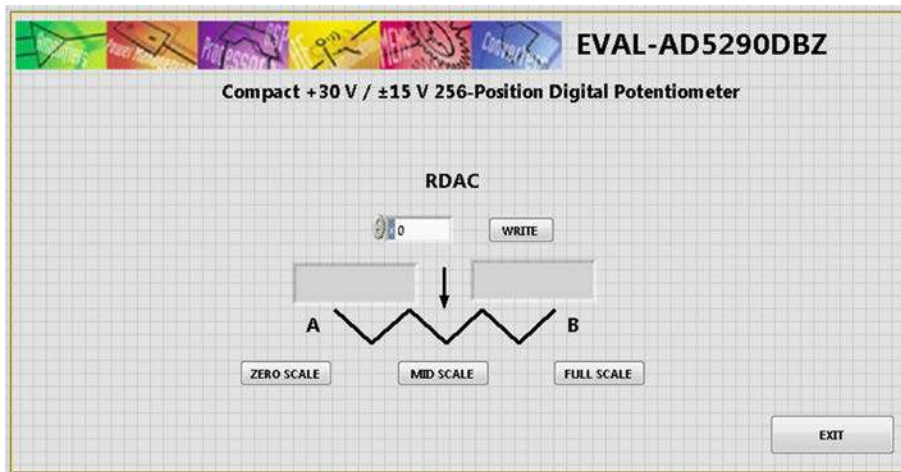

Figure 3. EVAL-AD5290DBZ Software Main Window

EVALUATION BOARD SCHEMATICS AND ARTWORK

MOTHERBOARD

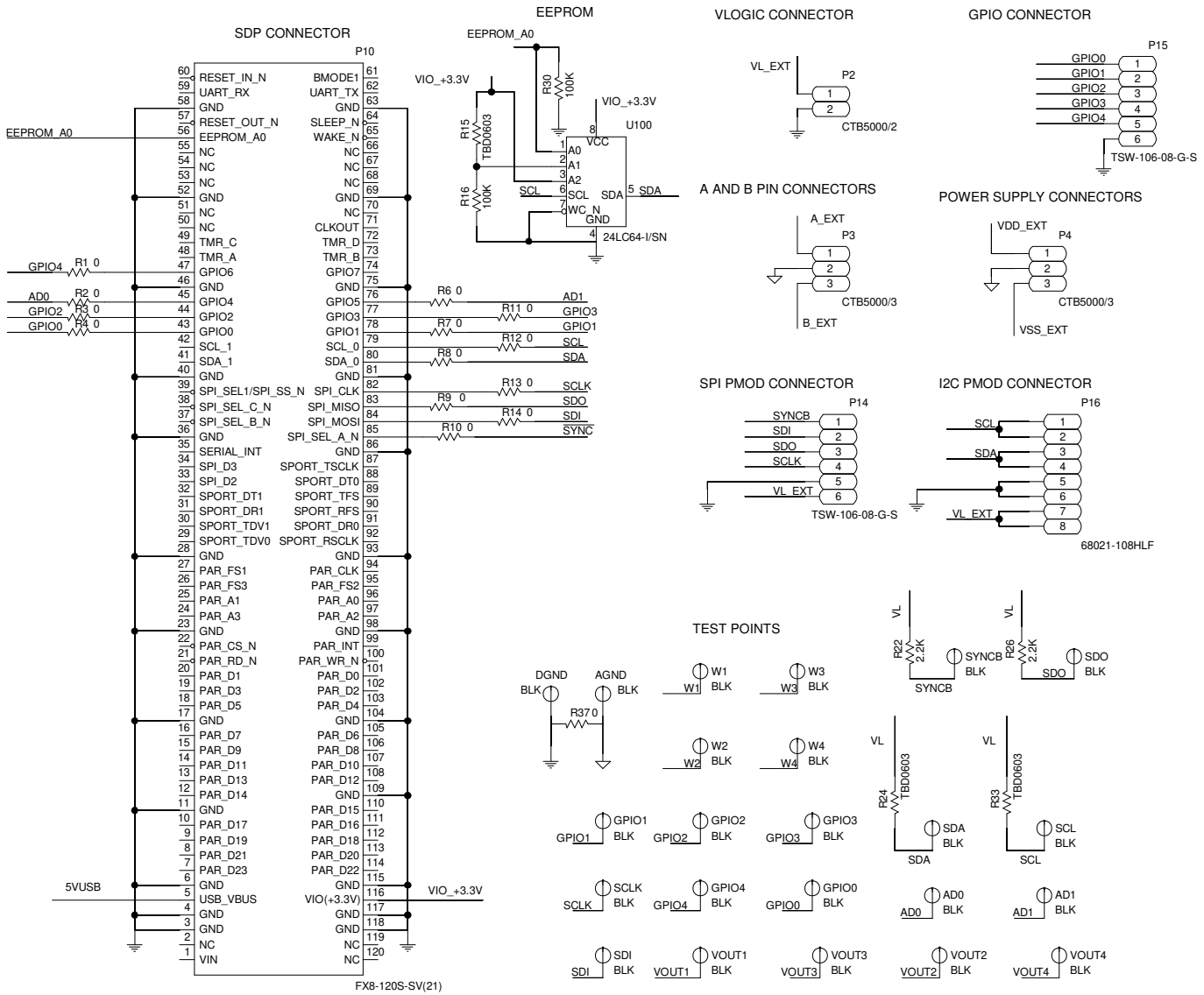
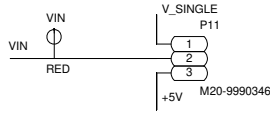
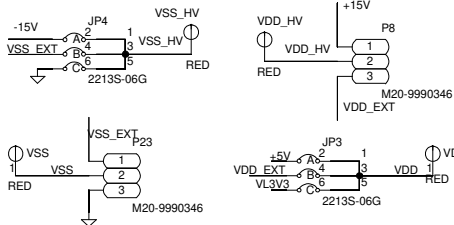

Figure 4. SDP Connector and Power Supply

SELECTION BETWEEN 5VUSB AND VSINGLE SUPPLY



JUMPER SETTINGS FOR THE SUPPLY



SELECTION BETWEEN VLOGIC EXTERNAL AND 3.3V FROM THE SDP

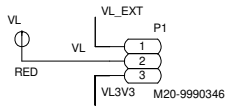

JUMPER SETTINGS FOR THE A AND B TERMINAL

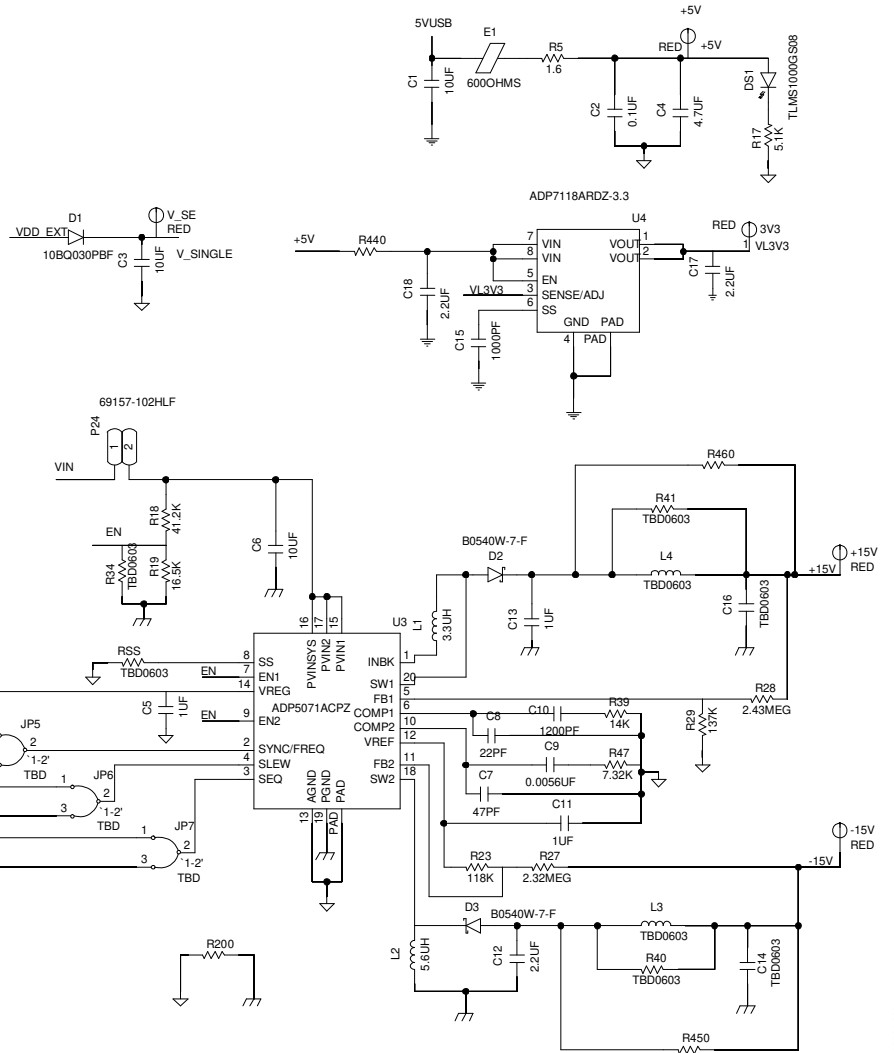
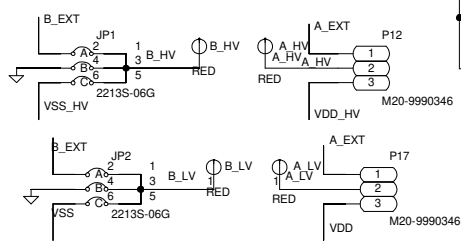

Figure 5. EVAL-MB-HV-SDZ Schematic—Power Supply

17234-008

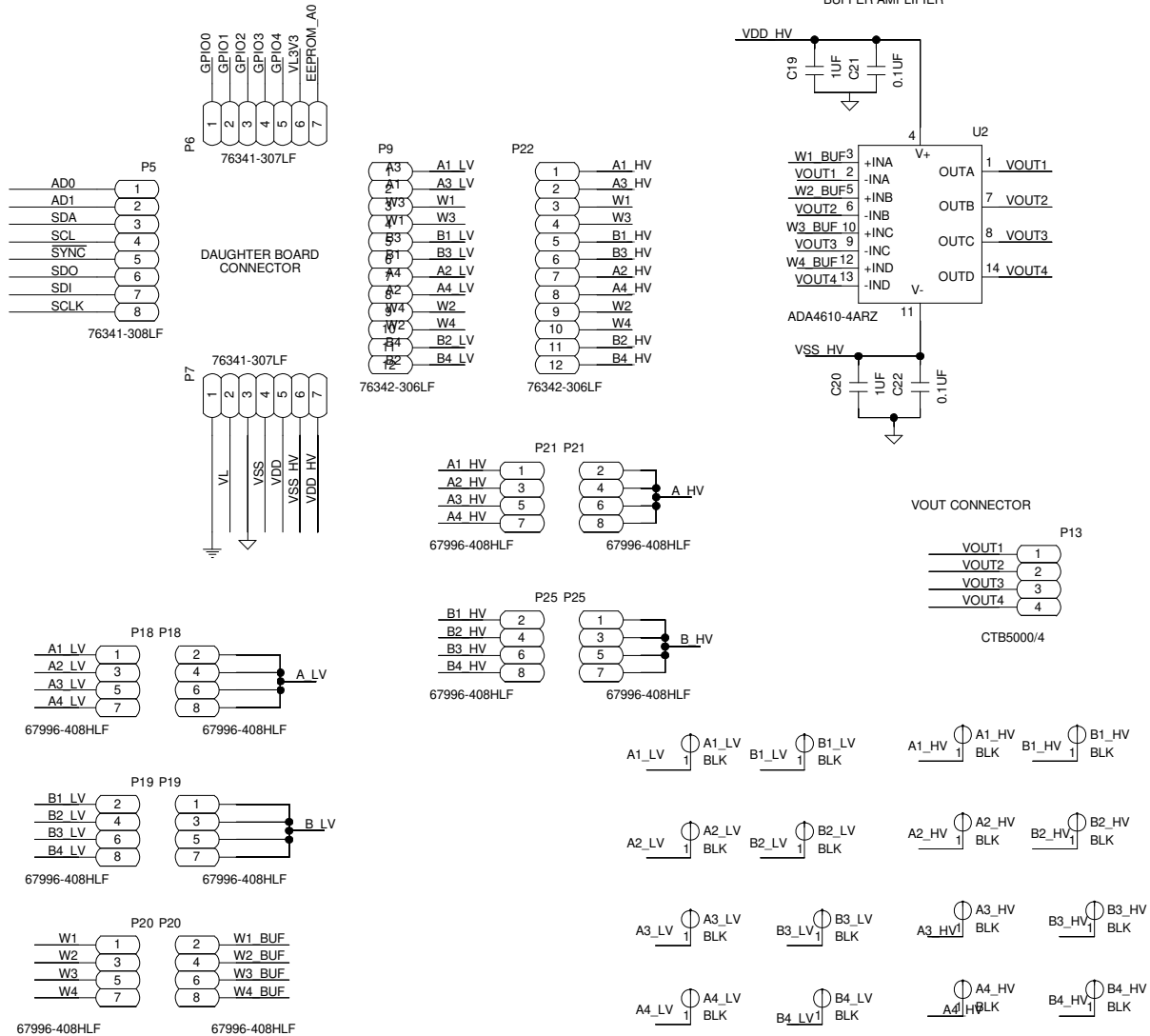

Figure 6. EVAL-MB-HV-SDZ Schematic—Daughterboard Connectors

17216-009

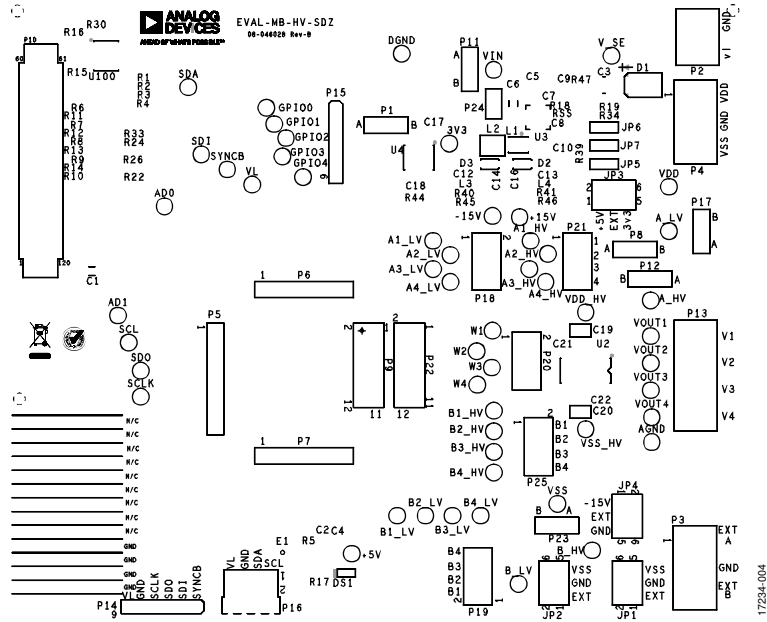

Figure 7. Silkscreen Primary

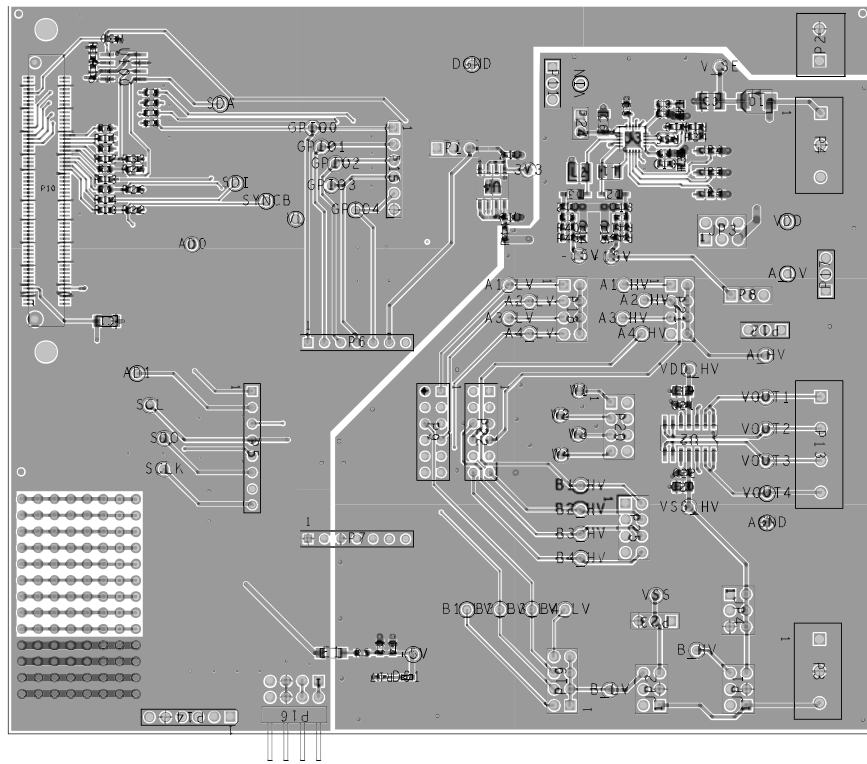
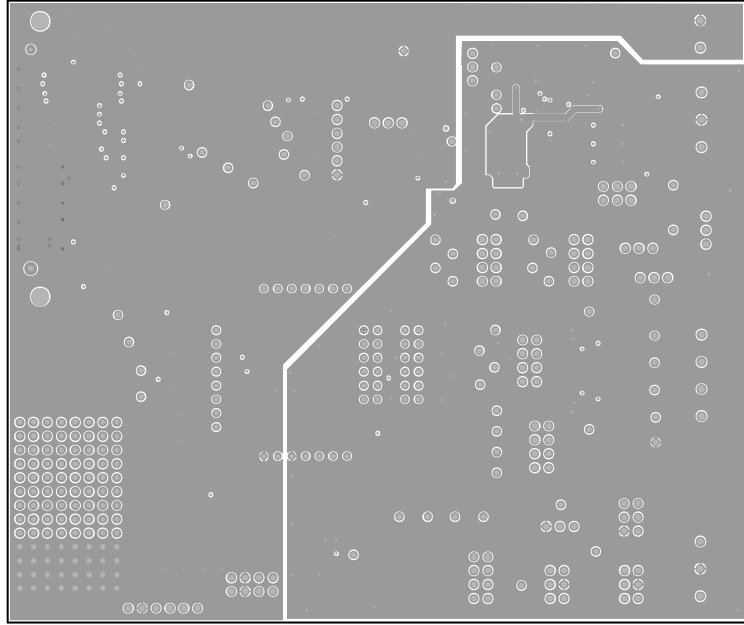
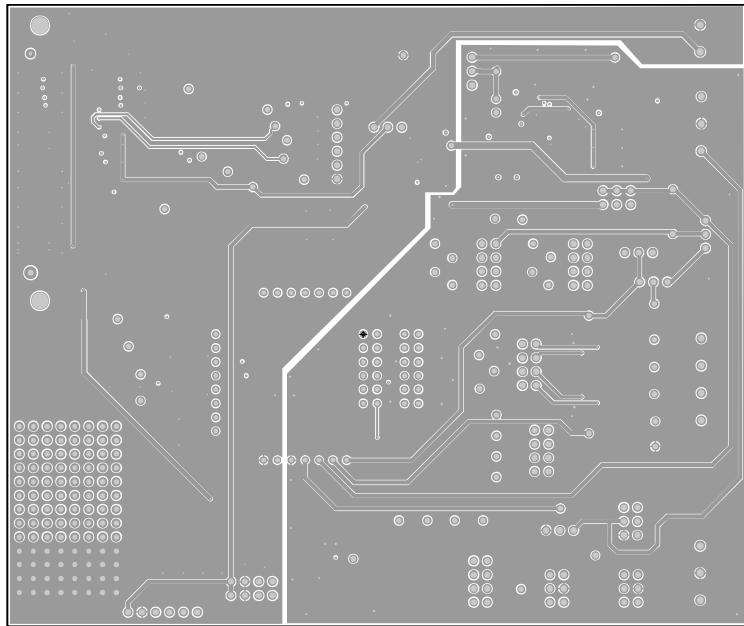

Figure 8. Component Placement Drawing of Motherboard



17234-005

Figure 9. Ground Planes



17234-006

Figure 10. Power Ground Planes

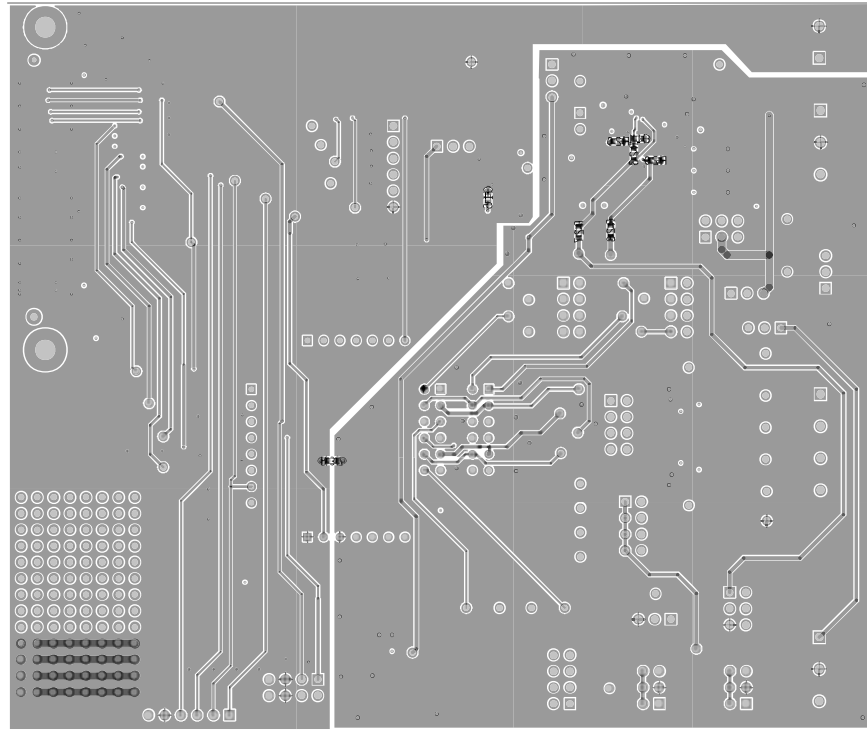

Figure 11. Bottom Layer Side PCB Drawing of Motherboard

17234-114

DAUGHTER BOARD

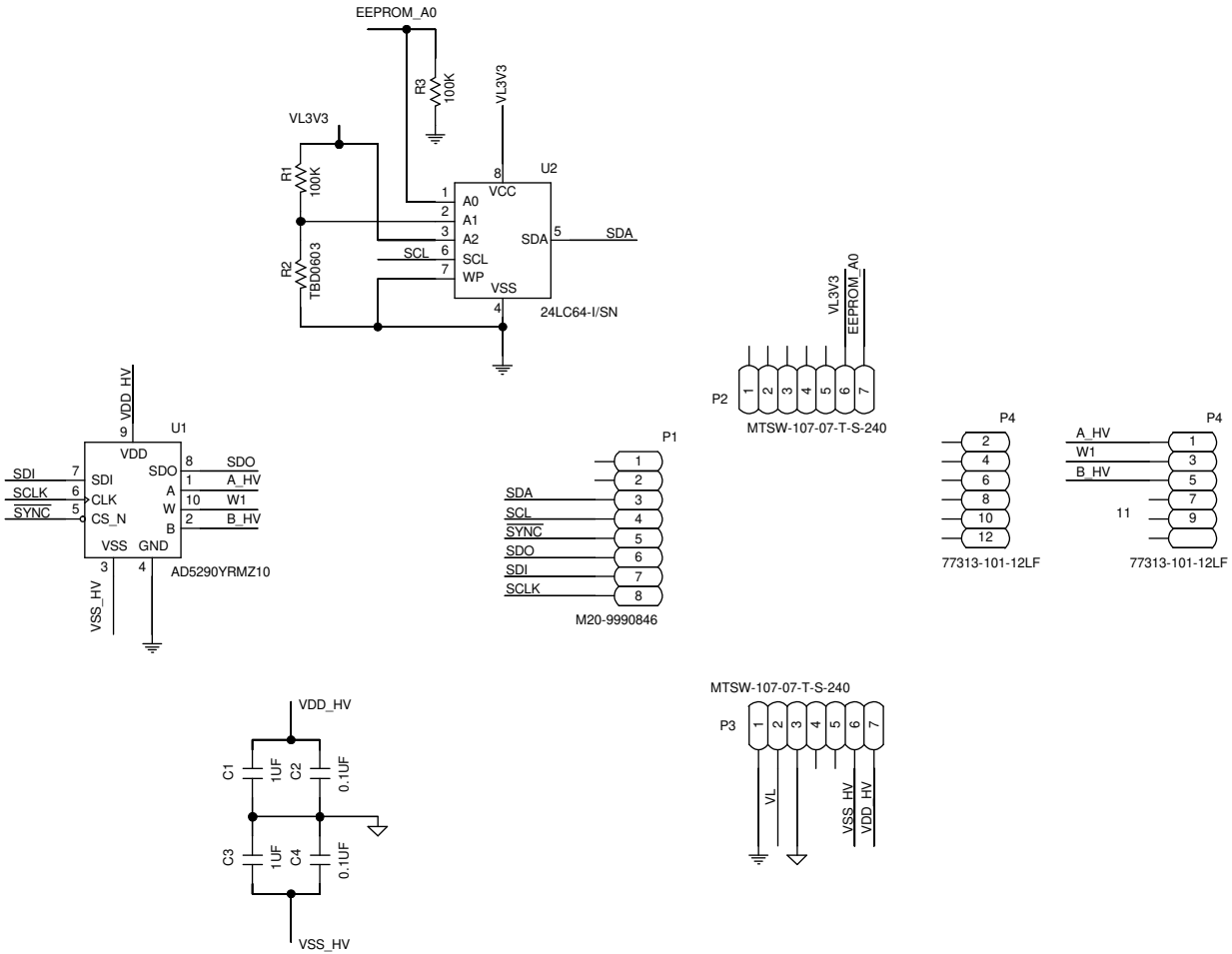

Figure 12. EVAL-AD5290DBZ Schematic

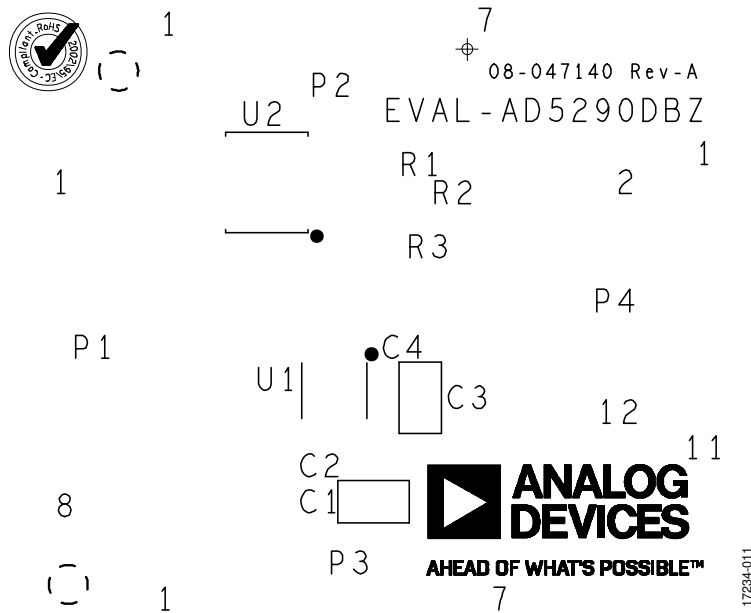
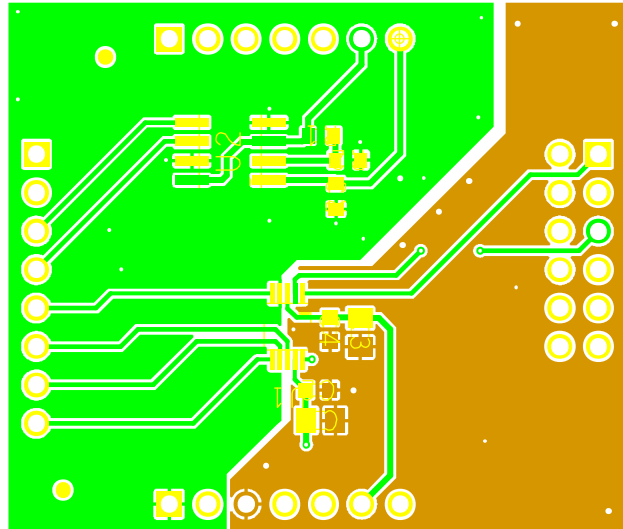
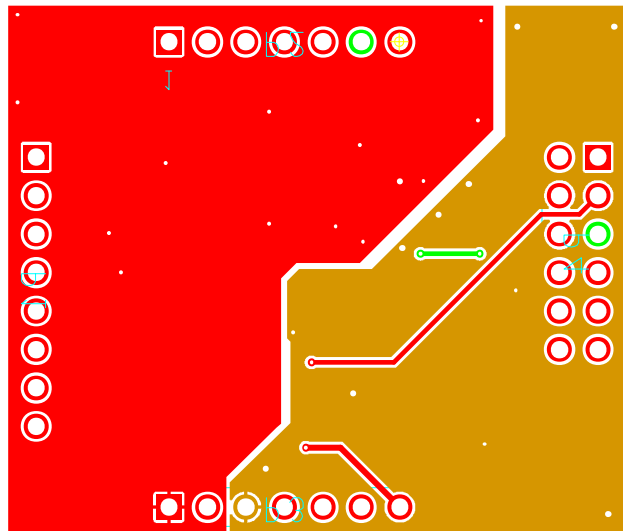

Figure 13. Silkscreen



17234-012

Figure 14. Layer 1, Primary



17234-013

Figure 15. Layer 2, Secondary

ORDERING INFORMATION

BILL OF MATERIALS

Table 3. Motherboard

Qty	Reference Designator	Description	Part Number
15	+5V, +15V, -15V, 3V3, A_HV, A_LV, B_HV, B_LV, VDD, VDD_HV, VIN, VL, VSS, VSS_HV, V_SE	Red test point	20-313137
39	A1_HV, A1_LV, A2_HV, A2_LV, A3_HV, A3_LV, A4_HV, A4_LV, AD0, AD1, AGND, B1_HV, B1_LV, B2_HV, B2_LV, B3_HV, B3_LV, B4_HV, B4_LV, DGND, GPIO0, GPIO1, GPIO2, GPIO3, GPIO4, SCL, SCLK, SDA, SDI, SDO, SYNCB, VOUT1, VOUT2, VOUT3, VOUT4, W1, W2, W3, W4	Black test point	20-2137
2	C1, C6	10 μ F capacitor	GRM31CR71A106K
1	C10	1200 pF capacitor	C1608C0G1H122J
2	C5, C11	1 μ F capacitor	JMK107B7105MA
1	C12	2.2 μ F capacitor	GRM188R6YA225KA12D
1	C13	1 μ F capacitor	GRM188R61E105KA12D
2	C14, C16	Not populated	Not populated
1	C15	1000 pF capacitor	GRM188R71H102KA01D
2	C17, C18	2.2 μ F capacitor	GRM188R60J225KE19D
2	C19, C20	1 μ F capacitor	GRM216R61E105KA12D
3	C2, C21, C22	0.1 μ F capacitor	GRM188R71H104KA93D
1	C3	10 μ F capacitor	GRM32ER61H106KA12L
1	C4	4.7 μ F capacitor	GRM188R60J475KE19
1	C7	47 pF capacitor	06035A470JAT2A
1	C8	22 pF capacitor	CC0603JRNPO9BN220
1	C9	0.0056 μ F capacitor	06035C562JAT2A
1	D1	Schottky diode	10BQ030PBF
2	D2, D3	Schottky diode	B0540W-7-F
1	DS1	Red LED	TLMS1000-GS08
1	E1	Ferrite bead 600 Ω	BLM31PG6015N1L
4	JP1, JP2, JP3, JP4	Three-row, 2-pin header	2213S-06G
3	JP5, JP6, JP7	Not populated	Not populated
1	L1	3.3 μ H inductor	LQH32PN3R3NN0L
1	L2	5.6 μ H inductor	ME3220-562MLB
2	L3, L4	Not populated	Not populated
6	P1, P8, P11, P12, P17, P23	3-pin header	M20-9990346
1	P10	120-pin connector	FX8-120S-SV(21)
1	P13	Four contacts, wire to board connector	CTB5000/4
2	P14, P15	6-pin header	TSW-106-08-G-S
1	P16	Two-row, 2-pin right angle header	68021-108HLF
5	P18, P19, P20, P21, P25	Four-row, 2-pin header	67996-408HLF
1	P2	Two contacts, wire to board connector	CTB5000/2
2	P9, P22	Six-row, 2-pin female header	76342-306LF
1	P24	2-pin header	69157-102HLF
2	P3, P4	Three contacts, wire to board connector	CTB5000/3
1	P5	8-pin female header	76341-308LF
2	P6, P7	7-pin female header	76341-307LF
18	R1, R2, R3, R4, R6, R7, R8, R9, R10, R11, R12, R13, R14, R20, R37, R44, R45, R46	0 Ω resistors	MC0603WG00000T5E-TC
7	R15, R24, R33, R34, R40, R41, RSS	Not populated	Not populated

Qty	Reference Designator	Description	Part Number
2	R16, R30	100 kΩ resistors	MC 0.063W 0603 1% 100K
1	R17	5.1 kΩ resistors	CRCW04025K10FKED
1	R18	41.2 kΩ resistors	CRCW060341K2FKEA
1	R19	16.5 kΩ resistors	ERA-3AEB1652V
2	R22, R26	2.2 kΩ resistors	MC 0.063W 0603 1% 2K2
1	R23	118 kΩ resistors	ERJ-3EKF1183V
1	R27	2.32 MΩ resistors	CRCW06032M32FKEA
1	R28	2.43 MΩ resistors	CRCW06032M43FKEA
1	R29	137 kΩ resistors	MC0063W06031137K
1	R39	14 kΩ resistors	ERJ-6ENF1402V
1	R47	7.32 kΩ resistors	ERJ-6ENF7321V
1	R5	1.6 Ω resistors	SG73S1JTDD1R60F
1	U100	I ² C serial electronically erasable programmable read only memory (EEPROM)	24LC64-I-SN
1	U2	Low noise, precision, rail-to-rail output, junction field effect transistor (JFET) dual op amp	ADA4610-4ARZ
1	U3	DC-to-dc switching regulator	ADP5071ACPZ-R7
1	U4	Low noise, complementary metal-oxide semiconductor (CMOS) low dropout (LDO) linear regulator	ADP7118ARDZ-3.3

Table 4. Daughter Board

Qty	Reference Designator	Description	Part Number
2	C1, C3	1 μF capacitor	GRM216R61E105KA12D
2	C2, C4	0.1 μF capacitor	GRM188R71H104KA93D
1	P1	8-pin jumper	M20-9990846
2	P2, P3	7-pin jumpers	TSW-107-07-T-S-240
1	P4	Six-row, 2-pin header	77313-101-12LF
2	R1, R3	100 kΩ resistors	ERJ-3EKF1003V
1	R2	Not populated	Not populated
1	U1	Compact, +30 V or ±15 V, 256-position digital potentiometer	AD5290YRMZ10
1	U2	I ² C serial EEPROM	24LC64-I/SN

NOTES

I²C refers to a communications protocol originally developed by Philips Semiconductors (now NXP Semiconductors).

**ESD Caution**

ESD (electrostatic discharge) sensitive device. Charged devices and circuit boards can discharge without detection. Although this product features patented or proprietary protection circuitry, damage may occur on devices subjected to high energy ESD. Therefore, proper ESD precautions should be taken to avoid performance degradation or loss of functionality.

Legal Terms and Conditions

By using the evaluation board discussed herein (together with any tools, components documentation or support materials, the "Evaluation Board"), you are agreeing to be bound by the terms and conditions set forth below ("Agreement") unless you have purchased the Evaluation Board, in which case the Analog Devices Standard Terms and Conditions of Sale shall govern. Do not use the Evaluation Board until you have read and agreed to the Agreement. Your use of the Evaluation Board shall signify your acceptance of the Agreement. This Agreement is made by and between you ("Customer") and Analog Devices, Inc. ("ADI"), with its principal place of business at One Technology Way, Norwood, MA 02062, USA. Subject to the terms and conditions of the Agreement, ADI hereby grants to Customer a free, limited, personal, temporary, non-exclusive, non-sublicensable, non-transferable license to use the Evaluation Board FOR EVALUATION PURPOSES ONLY. Customer understands and agrees that the Evaluation Board is provided for the sole and exclusive purpose referenced above, and agrees not to use the Evaluation Board for any other purpose. Furthermore, the license granted is expressly made subject to the following additional limitations: Customer shall not (i) rent, lease, display, sell, transfer, assign, sublicense, or distribute the Evaluation Board; and (ii) permit any Third Party to access the Evaluation Board. As used herein, the term "Third Party" includes any entity other than ADI, Customer, their employees, affiliates and in-house consultants. The Evaluation Board is NOT sold to Customer; all rights not expressly granted herein, including ownership of the Evaluation Board, are reserved by ADI. CONFIDENTIALITY. This Agreement and the Evaluation Board shall all be considered the confidential and proprietary information of ADI. Customer may not disclose or transfer any portion of the Evaluation Board to any other party for any reason. Upon discontinuation of use of the Evaluation Board or termination of this Agreement, Customer agrees to promptly return the Evaluation Board to ADI. ADDITIONAL RESTRICTIONS. Customer may not disassemble, decompile or reverse engineer chips on the Evaluation Board. Customer shall inform ADI of any occurred damages or any modifications or alterations it makes to the Evaluation Board, including but not limited to soldering or any other activity that affects the material content of the Evaluation Board. Modifications to the Evaluation Board must comply with applicable law, including but not limited to the RoHS Directive. TERMINATION. ADI may terminate this Agreement at any time upon giving written notice to Customer. Customer agrees to return to ADI the Evaluation Board at that time. LIMITATION OF LIABILITY. THE EVALUATION BOARD PROVIDED HEREUNDER IS PROVIDED "AS IS" AND ADI MAKES NO WARRANTIES OR REPRESENTATIONS OF ANY KIND WITH RESPECT TO IT. ADI SPECIFICALLY DISCLAIMS ANY REPRESENTATIONS, ENDORSEMENTS, GUARANTEES, OR WARRANTIES, EXPRESS OR IMPLIED, RELATED TO THE EVALUATION BOARD INCLUDING, BUT NOT LIMITED TO, THE IMPLIED WARRANTY OF MERCHANTABILITY, TITLE, FITNESS FOR A PARTICULAR PURPOSE OR NONINFRINGEMENT OF INTELLECTUAL PROPERTY RIGHTS. IN NO EVENT WILL ADI AND ITS LICENSORS BE LIABLE FOR ANY INCIDENTAL, SPECIAL, INDIRECT, OR CONSEQUENTIAL DAMAGES RESULTING FROM CUSTOMER'S POSSESSION OR USE OF THE EVALUATION BOARD, INCLUDING BUT NOT LIMITED TO LOST PROFITS, DELAY COSTS, LABOR COSTS OR LOSS OF GOODWILL. ADI'S TOTAL LIABILITY FROM ANY AND ALL CAUSES SHALL BE LIMITED TO THE AMOUNT OF ONE HUNDRED US DOLLARS (\$100.00). EXPORT. Customer agrees that it will not directly or indirectly export the Evaluation Board to another country, and that it will comply with all applicable United States federal laws and regulations relating to exports. GOVERNING LAW. This Agreement shall be governed by and construed in accordance with the substantive laws of the Commonwealth of Massachusetts (excluding conflict of law rules). Any legal action regarding this Agreement will be heard in the state or federal courts having jurisdiction in Suffolk County, Massachusetts, and Customer hereby submits to the personal jurisdiction and venue of such courts. The United Nations Convention on Contracts for the International Sale of Goods shall not apply to this Agreement and is expressly disclaimed.