

XL CONNECTOR

5.0 mm pitch/Wire-to-Board connectors/Crimp style and Mating style

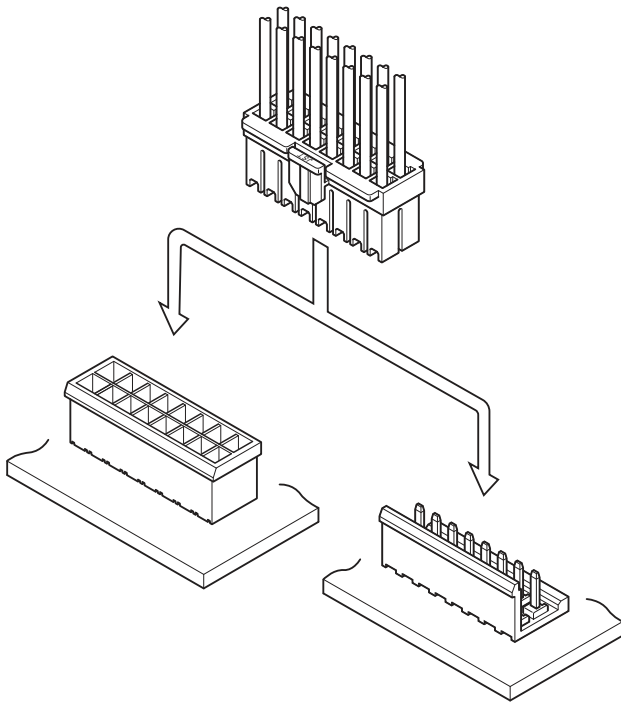

This is a highly reliable wire-to-board connector developed based on the proven track record of VH connectors, which are already used in numerous electronic and electrical equipment such as home appliances, vending machines, and office machines.

- Outstanding contact insertion workability
- High reliability box-shaped contact
- Deployable for wire-to-wire connections

Standards

Ⓡ : Recognized E 60389

Ⓢ : Certified LR 20812

⚠ : R75150

Specifications

- Current rating: 10 A AC/DC (2 circuits/ AWG #16)

※ The following table shows the rated current when applying current for all circuits in each combination of the number of circuits and the wire to be used.

Unit: A

No. of circuits	Wire size (AWG)					
	#16	#18	#20	#22	#24	#26
2	10	6	5	4	3	3
3	9	5	4	3	3	2
4	9	5	4	3	3	2
8	6	4	3	3	2	2
12	6	4	3	3	2	2
16	5	3	2	2	1	1

Note) Notes on parallel branching current:

Do not branch to the multiple circuits in parallel current which is exceeds the rated current, as it may cause problems such as imbalance when applying current.

If it is unavoidable that branch in parallel is necessary, design the circuits while suppressing the unbalanced current and proving the sufficient margin to the rated current.

- Voltage rating: 150 V AC/DC
- Temperature range: -25°C to +90°C
(including temperature rise in applying electrical current)
- Contact resistance:
Initial value/ 7 mΩ max.
After environmental tests/ 10 mΩ max.
- Insulation resistance: 1,000 MΩ min.
- Withstanding voltage:
There shall be no breakdown or flashover while applying 1,500 VAC for one minute.
- Applicable wire range: Conductor size/ AWG #26 to #16
- Applicable PC board thickness: 1.6 mm

* In using the products, refer to "Handling Precautions for Terminals and Connectors" described on our website (Technical documents of Product information page).

- * RoHS2 compliance
- * Dimensional unit: mm
- * Contact JST for details.

PC board layout and Assembly layout

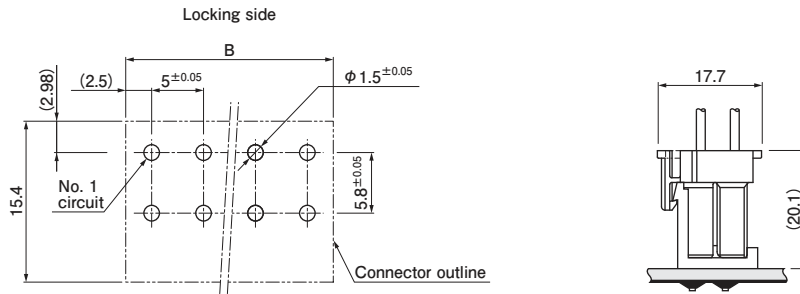

- Note: 1. The figure of PC board layout is the figure viewed from the connector mounting side.
 2. Dimension B: See "Header" section on page 4.
 3. Tolerance for the PCB hole pitch shall be ± 0.05 and shall not accumulate.
 4. Hole dimensions differ according to the type of PC board and piercing method.
 The above dimensions are reference values. Please contact JST for details.

PC board layout and Assembly layout/ HDB type

Top entry type

<2 circuits>

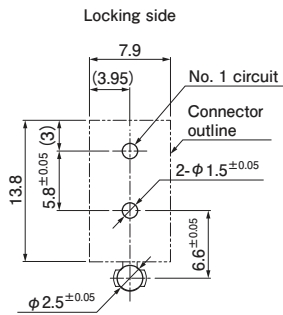

<3 circuits>

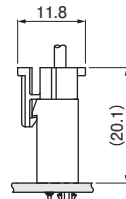
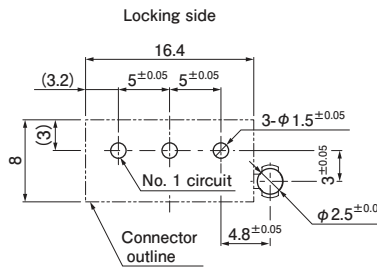

Top entry type :
3 circuits

<4 circuits>

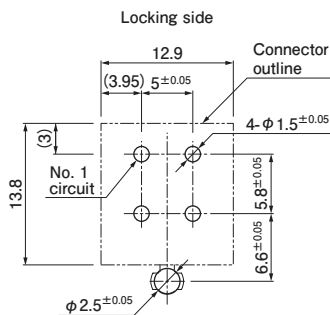

<6 circuits>

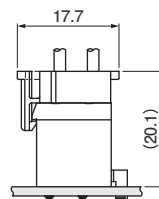
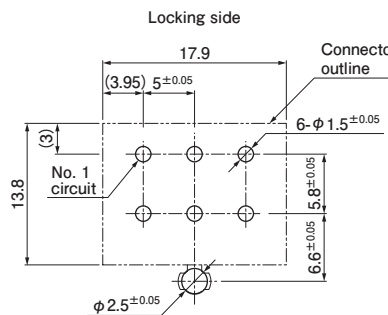

Top entry type :
2, 4, 6 circuits

Side entry type

<2 circuits>

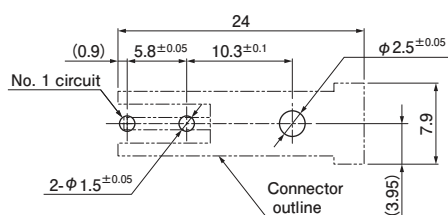

<4 circuits>

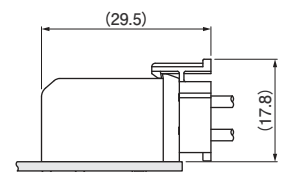
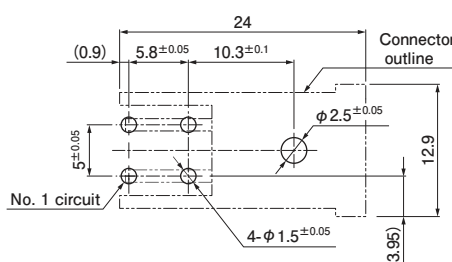

- Note: 1. The figure of PC board layout is the figure viewed from the connector mounting side.
 2. Tolerance for the PCB hole pitch shall be ± 0.05 and shall not accumulate.
 3. Hole dimensions differ according to the type of PC board and piercing method.
 The above dimensions are reference values. Please contact JST for details.

XL CONNECTOR

PC board layout and Assembly layout/ HDS type

Top entry type

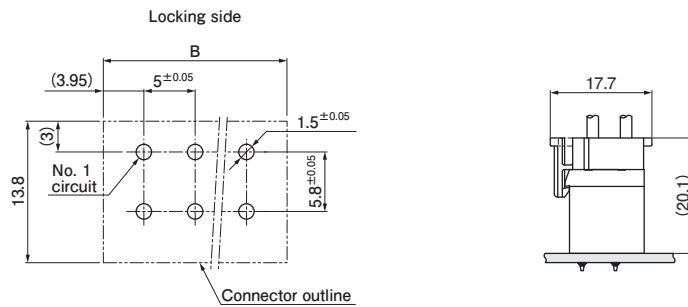

Side entry type

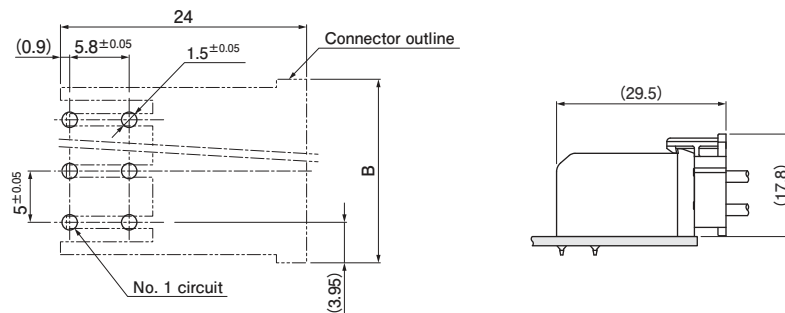

- Note: 1. The figure of PC board layout is the figure viewed from the connector mounting side.
 2. Dimension B: See "Header/HDS type" section on page 6
 3. Tolerance for the PCB hole pitch shall be ± 0.05 and shall not accumulate.
 4. Hole dimensions differ according to the type of PC board and piercing method.
 The above dimensions are reference values. Please contact JST for details.

Socket contact

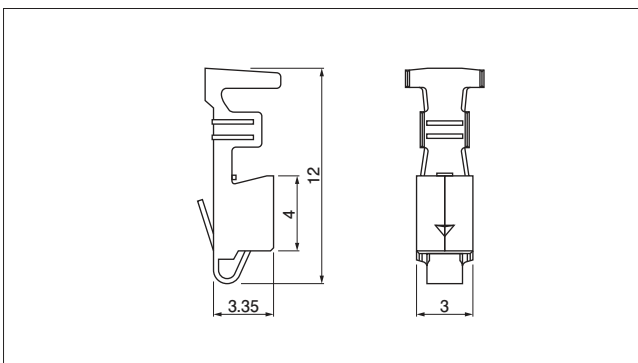

Model No.	Applicable wire range		Q'ty/ reel
	Conductor size AWG (mm ²)	Insulation O.D. (mm)	
SXF-01T-P0.7	#26 to #20 (0.13 to 0.5)	1.3 to 2.7	3,000
SXF-41T-P0.7	#20 to #16 (0.5 to 1.25)	1.9 to 3.1	
	#22×2 wires to #20×2 wires (0.3×2 wires to 0.5×2 wires)	1.7×2 wires to 2.0×2 wires	

Material and Surface finish, etc.

Phosphor bronze, tin-plated

RoHS2 compliance

Crimping machine

Contact	Crimping machine	Applicator	Crimp applicator with dies
SXF-01T-P0.7	AP-K2N	MKS-L	APLMK SXF01-07
SXF-41T-P0.7			APLMK SXF41-07

Note: Contact JST for fully automatic crimping applicator.

XL CONNECTOR

Plug housing

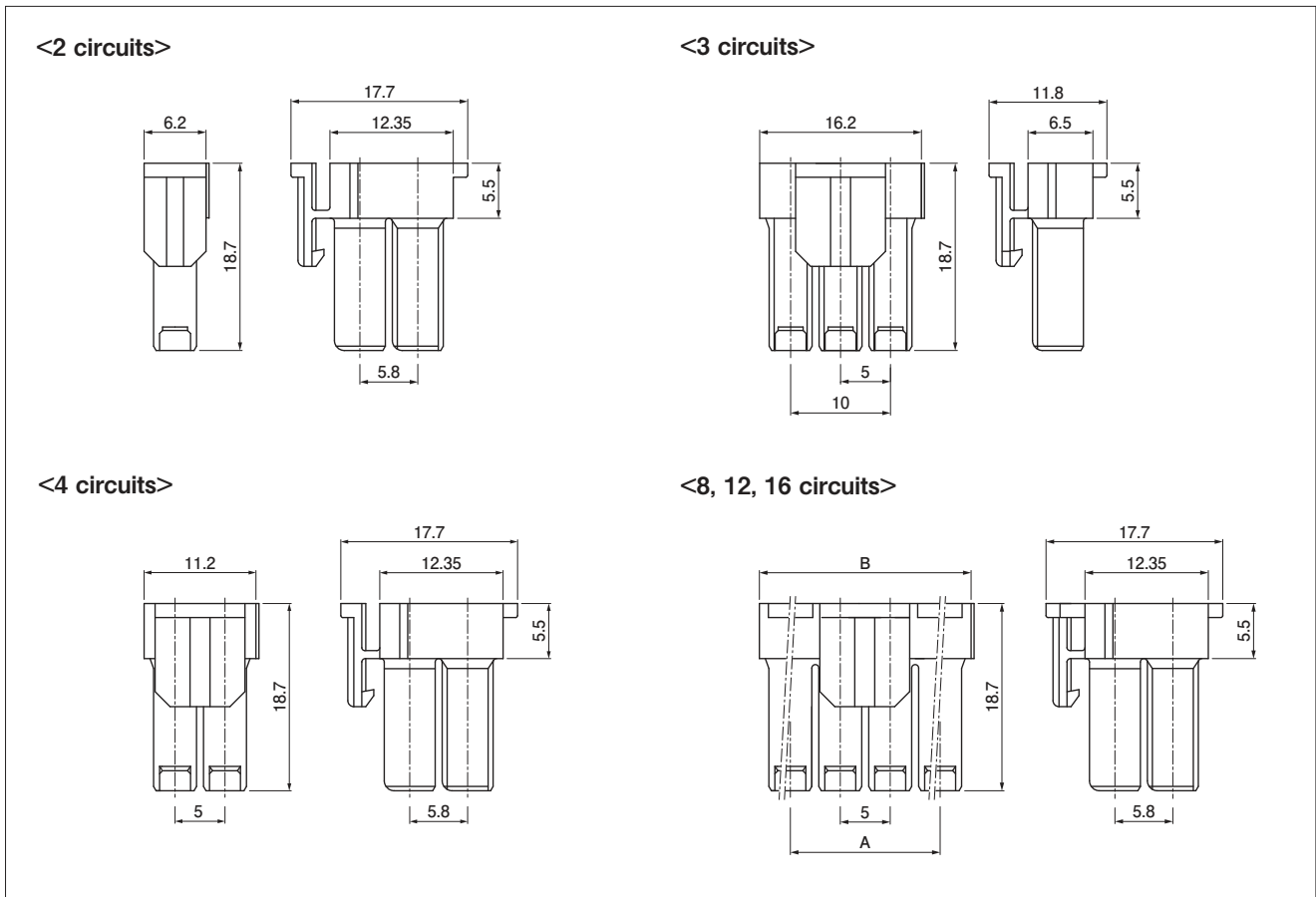

No. of circuits	Model No.	Dimensions (mm)		Q'ty/bag
		A	B	
2	XLP-02V	—	—	500
3	XLP-03V	—	—	500
4	XLP-04V	—	—	500
8	XLP-08V	15.0	21.2	500
12	XLP-12V	25.0	31.2	200
16	XLP-16V	35.0	41.2	200

Material and Surface finish, etc.

PA 66, UL94V-0, natural (white)

RoHS2 compliance

Header

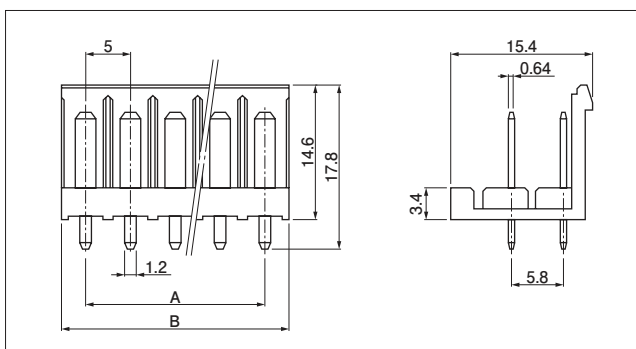

No. of circuits	Model No.	Dimensions (mm)		Q'ty/box
		A	B	
2	B02P-XL	—	5.0	250
4	B04P-XL	5.0	10.0	200
8	B08P-XL	15.0	20.0	100
12	B12P-XL	25.0	30.0	50
16	B16P-XL	35.0	40.0	50

Material and Surface finish, etc.

Post: Brass, copper-undercoated, tin-plated
Wafer: PA 66, UL94V-0, natural (white)

RoHS2 compliance This product displays (LF)(SN) on a label.

XL CONNECTOR

Header/ HDB type

Top entry type

<2 circuits>

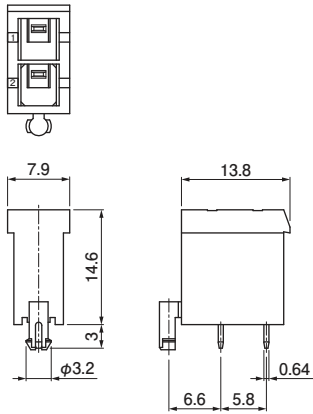

<3 circuits>

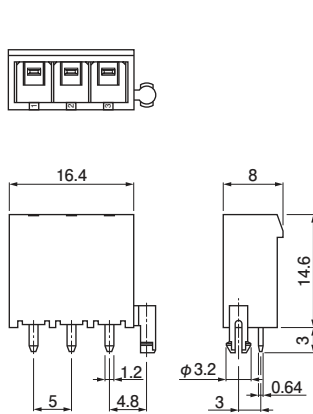

<4 circuits>

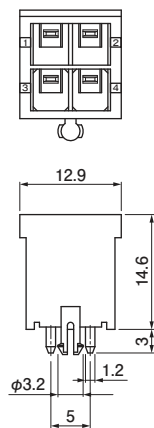

<6 circuits>

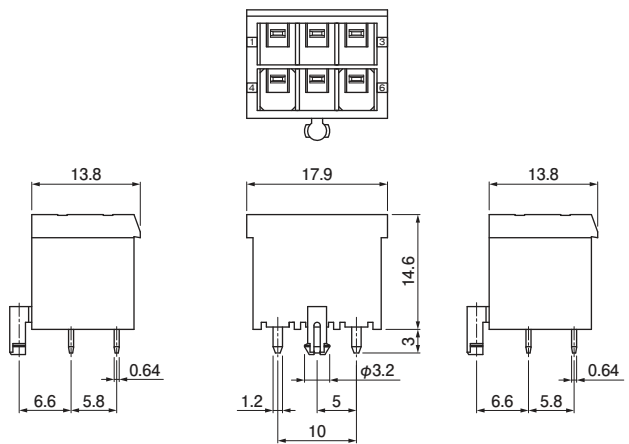

Side entry type

<2 circuits>

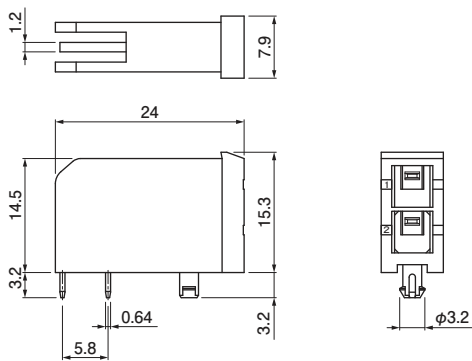

<4 circuits>

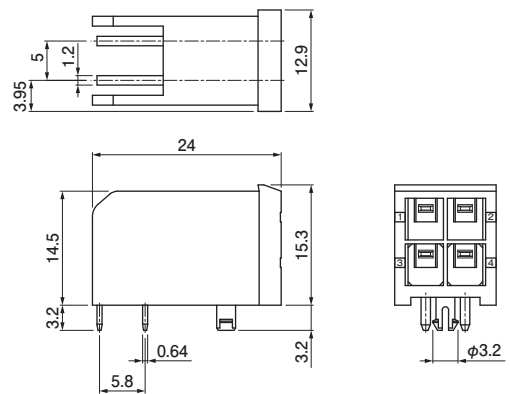

No. of circuits	Model No.		Q'ty/box	
	Top entry type	Side entry type	Top entry type	Side entry type
2	B02P-XL-HDB	S02P-XL-HDB	200	100
3	B03P-XL-HDB	—	200	—
4	B04P-XL-HDB	S04P-XL-HDB	200	100
6	B06P-XL-HDB	—	100	—

Material and Surface finish, etc.

Post: Brass, copper-undercoated, tin-plated
Wafer: PA 66, UL94V-0, natural (white)

RoHS2 compliance This product displays (LF)(SN) on a label.

XL CONNECTOR

Header/ HDS type

Top entry type

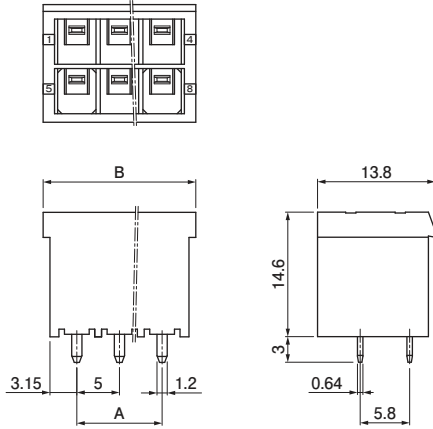

Side entry type

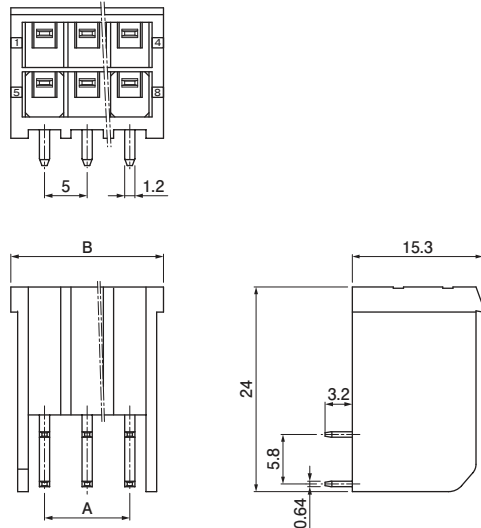

No. of circuits	Model No.		Dimensions (mm)		Q'ty/box	
	Top entry type	Side entry type	A	B	Top	Side
2	B02P-XL-HDS	—	—	7.9	200	—
4	B04P-XL-HDS	—	5.0	12.9	200	—
6	B06P-XL-HDS	—	10.0	17.9	100	—
8	B08P-XL-HDS	S08P-XL-HDS	15.0	22.9	100	40
12	B12P-XL-HDS	S12P-XL-HDS	25.0	32.9	50	30
16	B16P-XL-HDS	S16P-XL-HDS	35.0	42.9	40	20

Material and Surface finish, etc.

Post: Brass, copper-undercoated, tin-plated
 Wafer: PA 66, UL94V-0, natural (white)

RoHS2 compliance This product displays (LF)(SN) on a label.

Plug housing position location numbers

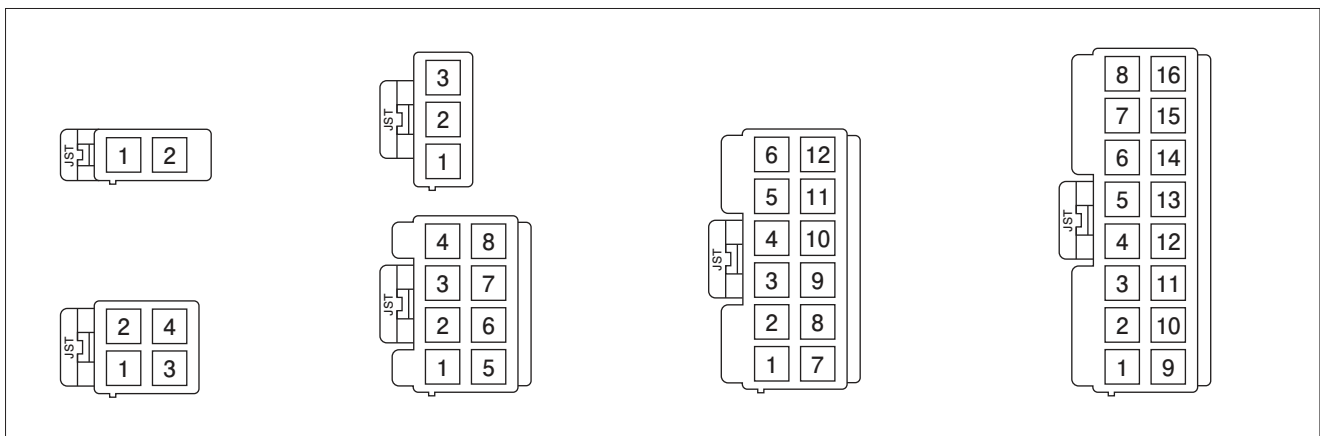

Model number allocation

Socket contact

SXF - 01 T - P 0.7

Supply form: S...Strip form
B...Loose piece

Series name

Type: Socket

Applicable wire range:
01...AWG #26 to #20
41...AWG #20 to #16
41...AWG #22 × 2 wires
to AWG #20 × 2 wires

Surface finish: Tin-plated

Material: Phosphor bronze

Applicable post size

Plug housing

XLP - 02 V -

Series name

Part name: Plug

No. of circuits

Flammability: UL94V-0

Color: Blank...Natural (White), K...Black, R...Red
E...Blue, Y...Yellow

Header

B 02 P - XL -

Header type: B...Top entry type
S...Side entry type

No. of circuits

Assembly product

Series name

Color : Blank...Natural (White), K...Black, R...Red
E...Blue, Y...Yellow

Header/ HDB type

B 02 P - XL - HDB -

Header type: B...Top entry type
S...Side entry type

No. of circuits

Assembly product

Series name

Type name

Color: Blank...Natural (White), K...Black, R...Red
E...Blue, Y...Yellow, M...Green, H...Gray, N...Brown
D...Orange, L...Lemon yellow

Header/ HDS type

B 08 P - XL - HDS -

Header type: B...Top entry type
S...Side entry type

No. of circuits

Assembly product

Series name

Type name

Color: Blank...Natural (White), K...Black, R...Red
E...Blue, Y...Yellow, L...Lemon yellow