

Tous droits strictement réservés. Reproduction ou communication à des tiers interdite sous quelque forme que ce soit sans autorisation écrite du propriétaire. Propriété de c.FCI. Droits de reproduction FCI.

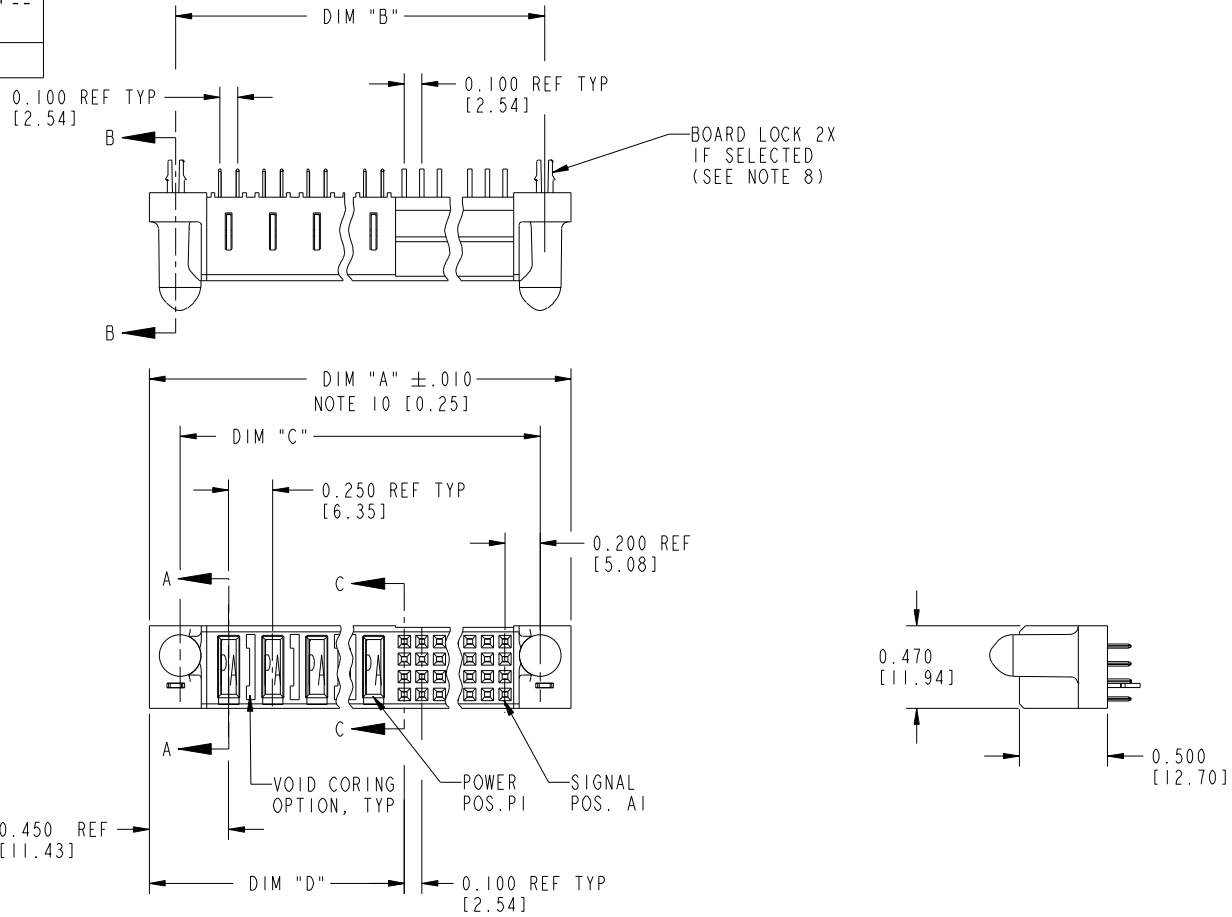

All rights strictly reserved. Reproduction or issue to third parties in any form whatever is not permitted without written authority from the proprietor. Property of FCI. Copyright FCI.

PRODUCT NUMBER
51741-A00CCDDDEF -- NOTE ①
SEE NOTE 1



mat'l code				SEE NOTE 2		tolerances unless otherwise specified		CUSTOMER		 www.fciconnect.com	
ltr	ecn no.	dr	date	linear	.XX±.01/0.XX±0.3		COPY		 title VERTICAL RECEPTACLE W/ GUIDE PIN SIGNAL / POWER		
H	DG05-0076	SW	04/11/05		.XXX±.005/0.XX±0.13		projection				
J	DG05-0153	SJ	06/09/05	angles	.XXX±.0020/.XX±.051		 INCH/MM		product family PWRBLADE code 213		
K	DG05-0479	CS	11/18/05		0°±2°		scale		size dwg no 51741 sheet 1 of 3		
L	DG08-0239	JC	09/11/08	dr	D. EATON	05-25-99	A		cage code 22526		
				enrg	J. BROWN	05-24-99					
				chr	J. BROWN	05-26-99					
				appd	J. BROWN	05-26-99					
sheet index	revision sheet	L	L	L							
		1	2	3							

Pro/E

cage code 22526

Tous droits strictement réservés. Reproduction ou communication à des tiers interdite sous quelque forme que ce soit sans autorisation écrite du propriétaire. Propriété de c FCI. Droits de reproduction FCI.



All rights strictly reserved. Reproduction or issue to third parties in any form whatever is not permitted without written authority from the proprietor. Property of FCI. Copyright FCI.

PRODUCT NUMBER
51741-A00CCCDDEF -- NOTE ①
SEE NOTE 1

1 | 2

3 |

4

DIM	LENGTH FORMULAS (SEE NOTE 10)
DIM "A"	.250 [6.35] x DD + .100 [2.54] x (CCC/4) + .650 [16.51] (NOTE 10)
DIM "B"	.250 [6.35] x DD + .100 [2.54] x (CCC/4) + .350 [8.89]
DIM "C"	.250 [6.35] x DD + .100 [2.54] x (CCC/4) + .300 [7.62]
DIM "D"	.250 [6.35] x DD + .375 [9.53]
DIM "F"	.250 [6.35] x DD + .100 [2.54] x (CCC/4) + .680 [17.27]
DIM "G"	.250 [6.35] x DD + .225 [5.72]

CONNECTOR NOTES

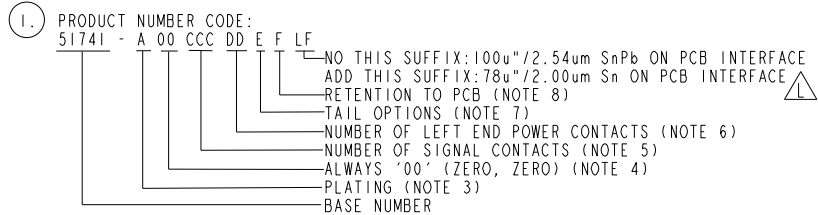

- ②. HOUSING MATERIAL: GLASS FILLED V-O HIGH TEMP THERMO PLASTIC.
SIGNAL CONTACT MATERIAL: COPPER ALLOY
POWER CONTACT MATERIAL: COPPER ALLOY
- ③. PLATING OPTION:
1 = SEE PRINT 10064183 FOR PLATING SPEC OF 51741-100CCCDDEF; 51741-100CCCDDEFLF
- ④. THIS PART NOT AVAILABLE WITH RIGHT SIDE POWER CONTACTS.
- ⑤. SIGNAL CONTACTS, 004 TO 148 AVAILABLE.
- ⑥. LEFT END POWER CONTACTS, 01 TO 20 AVAILABLE.
MAXIMUM OF 20 POWER CONTACTS PER CONNECTOR.
- ⑦. TAIL OPTIONS:
A = .135±.010 [3.43±.25] SOLDER TO BOARD
C = .135±.010 [3.43±.25] PRESS FIT

- ⑧. RETENTION TO PCB OPTIONS:
A = BOARD LOCK (REQUIRES .098 + .002, -.001 [2.49 +0.05, -0.03] THRU HOLE IN PCB)
BOARD LOCK TO BE USED IN CONJUNCTION WITH AN .092 PCB OR THICKER.
C = NO RETENTION FEATURE (ALL PRESS FIT).

- ⑨. MANUFACTURE'S NAME, P/N, AND DATE CODE TO APPEAR ON THIS SURFACE.
- ⑩. THE MAXIMUM OVERALL LENGTH (DIM A) OF A PART IS 8.00 [203.2].

- 11. PRODUCT SPECIFICATION GS-12-149.
- 12. REFERENCE 51698 FOR SPECIALS WORKSHEET.

PCB NOTES:

- 13. ALL DIMENSIONS ARE BASIC UNLESS OTHERWISE SPECIFIED.
- 14. ALL THROUGH HOLES ARE LOCATED WITH A TRUE POSITION OF .004 [0.01]
- 15. ALL HOLE DIAMETERS ARE FINISHED HOLE SIZE.
- 16. 0.0453±.001 [1.151±.02] DRILLED HOLES PLATED WITH 0.0003 [0.007] MIN SnPb OVER 0.001 [1.03] TO .003 [0.08] PLATING TO ACHIEVE A .040 ±.003 [1.02 ±.08] HOLE.
- 17. A SYMBOL WILL BE NEXT TO ANY DIMENSION, VIEW, OR NOTE WHICH HAS BEEN MODIFIED WITH THE CURRENT DRAWING REVISION.

mat'l code				SEE NOTE 2		tolerances unless otherwise specified		CUSTOMER			
ltr	ecn no.	dr	date	linear	.XX±.01/0.XX±0.3	projection		COPY		www.fciconnect.com	
L				linear	.XXX±.005/0.XX±0.13			title		VERTICAL RECEPTACLE W/ GUIDE PIN SIGNAL / POWER	
				angles	.XXX±.0020/.XXX±.051			product family		PWRBLADE	
				dr	0°±2°	INCH/MM		size		213	
				enrg	D. EATON 05-25-99	scale		dwg no		sheet	
				chr	J. BROWN 05-24-99	1:1		51741		2	
				appd	J. BROWN 05-26-99						
sheet index	revision sheet										

1 | 2

Pro/E

3 |

cage code 22526

4

Tous droits strictement réservés. Reproduction ou communication à des tiers interdite sous quelque forme que ce soit sans autorisation écrite du propriétaire. Propriété de c.FCI. Droits de reproduction FCI.



All rights strictly reserved. Reproduction or issue to third parties in any form whatever is not permitted without written authority from the proprietor. Property of FCI. Copyright FCI.

PRODUCT NUMBER
51741-A00CCDDDEF -- NOTE ①
SEE NOTE 1

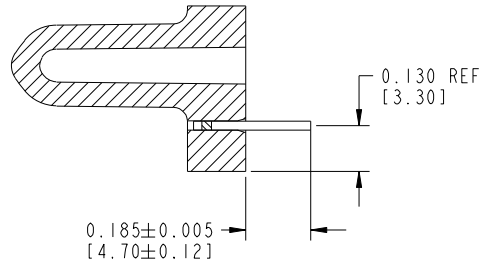

SECTION B-B
SCALE 2:1

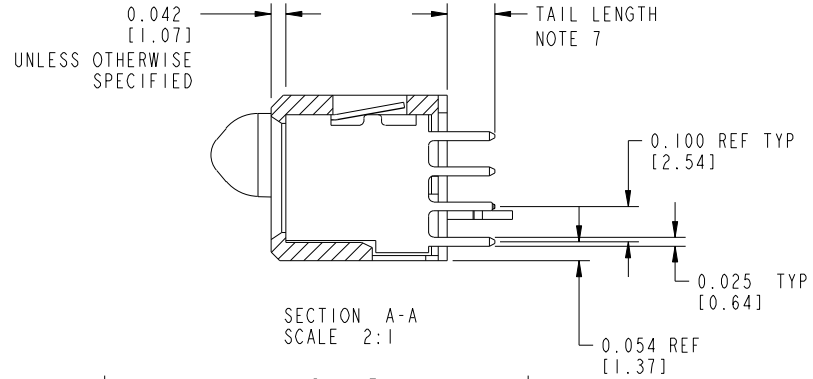

SECTION A-A
SCALE 2:1

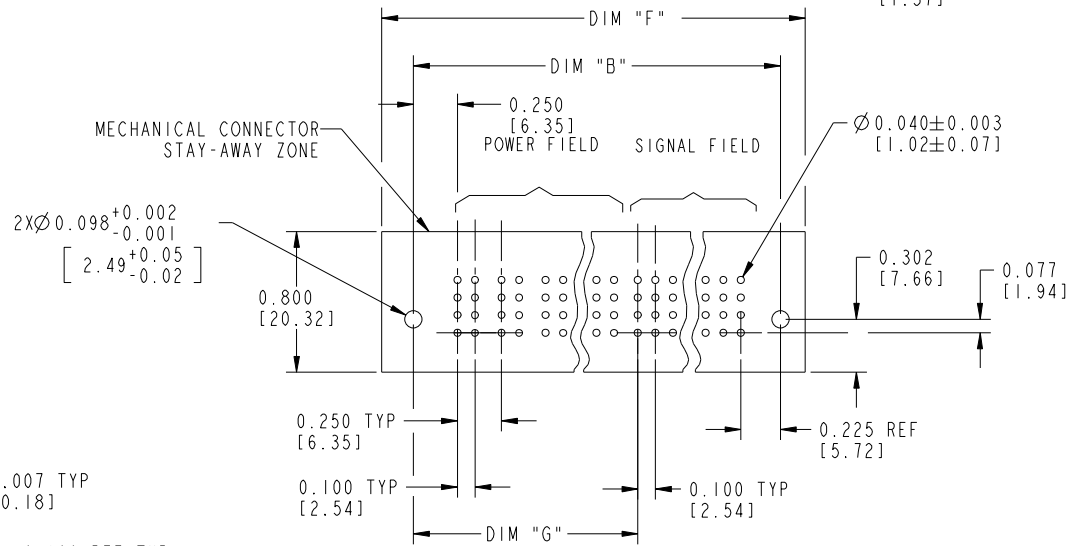

RECOMMENDED PCB LAYOUT

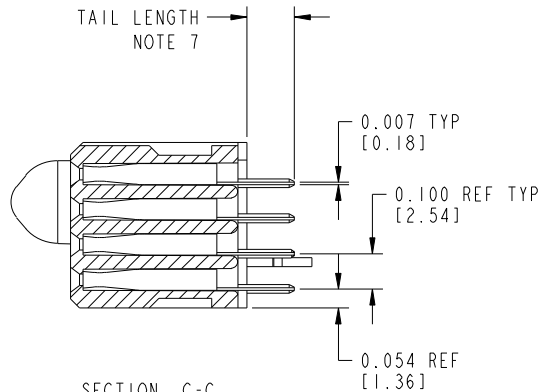

SECTION C-C
SCALE 2:1

mat'l code		SEE NOTE 2		tolerances unless otherwise specified		CUSTOMER		 www.fciconnect.com	
ltr	ecn no.	dr	date	linear	.XX±.01/0.XX±0.3	COPY		title	
L				linear	.XXX±.005/0.XX±0.13	projection		VERTICAL RECEPTACLE W/ GUIDE PIN SIGNAL / POWER	
				angles	.XXX±.0020/.XX±.051			product family	
				dr	D. EATON 05-25-99	INCH/MM		PWRBLADE	
				enr	J. BROWN 05-24-99	scale		code	
				chr	J. BROWN 05-26-99	1:1		213	
				appd	J. BROWN 05-26-99	A		sheet	
sheet index		revision sheet						3	
								cage code	
								22526	

Pro/E

cage code 22526