

7 W dual output flyback converter with standby managed by capacitive touch using VIPer0P and STM32L

Data brief



Features

- Smart standby architecture using the zero power mode (ZPM) for capacitive touch sensing in consumer electronics applications
- Enhanced system reliability thanks to VIPer0P 800 V avalanche rugged technology and its embedded protection
- Minimized system input power consumption: less than 30 mW at 230 V_{AC} in ZPM
- IEC55022 Class B conducted EMI compliant, even with reduced EMI filter, thanks to the frequency jittering feature
- IEC61000-4-2 (ESD), IEC61000-4-4 (EFT) and IEC61000-4-5 (Surge) compliant
- RoHS compliant

Description

This offline converter key feature is the zero power mode (ZPM), an idle state during which the device is totally shut down. The IC enters ZPM by pulling the OFF pin to SGND for more than 10 ms and exits ZPM (resuming normal switching) by pulling the ON pin to SGND for more than 20 μ s. This function can be tested via the tactile switches connected to the ON and OFF pins.

In ZPM the mains power consumption at 230 V_{AC} can be below 5 mW; the STEVAL-ISA192V1 evaluation board consumption is 30 mW due to the MCU polling strategy implemented at firmware level.

The board has a dual output (i.e., - 5 V and + 7 V based on flyback topology). The negative output is obtained by just connecting EAGND to the negative rail and a voltage divider among FB, EAGND and SGND. The positive output derives from the turn ratio of the transformer secondary windings.

To achieve extremely low input power consumption, the IC is biased through a diode coming from the + 7 V, which maintains the V_{CC} voltage high enough (> 4.5 V) to prevent the internal HV current source activation.

The STEVAL-ISA192V1 is equipped with the STM32L0 microcontroller which detects tactile push buttons and capacitive touch interface. The STM32L0 core manages VIPer0P to achieve minimum power consumption in ZPM, while supplying the microcontroller and user interface (capacitive touch and push button) and still maintaining the overall efficiency quite high in standard operation mode.

1 STEVAL-ISA192V1 characteristics

- Non-isolated flyback topology
- 85 – 265 V_{AC} input voltage range
- Dual output:
 - + 7 V, 400 mA
 - - 5 V, 800 mA
- 60 kHz fixed frequency operation
- Push button and capacitive touch interface for ZPM
- Input power consumption in ZPM:
 - Less than 10 mW at 85 V_{AC}
 - Less than 30 mW at 230 V_{AC}
 - Less than 40 mW at 265 V_{AC}
- Built-in soft start for improved system reliability
- Auto restart protections: overload/short circuit, maximum duty cycle counter, V_{CC} clamp, thermal shutdown
- Pulse-skip protection to prevent flux runaway
- SMPS board dimensions: 74 x 45 mm

2 Schematic diagram

Figure 1: STEVAL-ISA192V1 circuit schematic

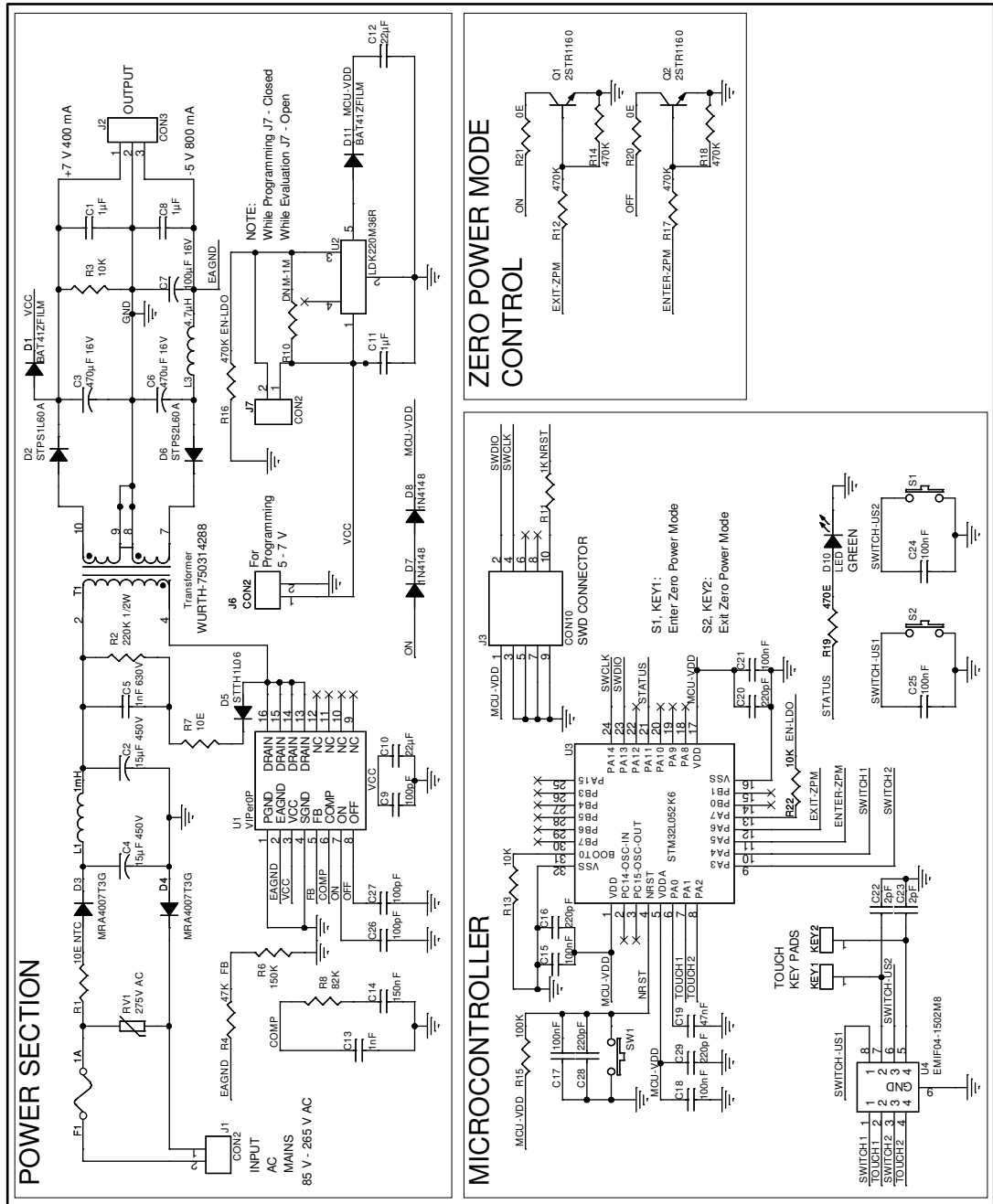

3 Revision history

Table 2: Document revision history

Date	Version	Changes
16-Feb-2017	1	Initial release.

IMPORTANT NOTICE – PLEASE READ CAREFULLY

STMicroelectronics NV and its subsidiaries ("ST") reserve the right to make changes, corrections, enhancements, modifications, and improvements to ST products and/or to this document at any time without notice. Purchasers should obtain the latest relevant information on ST products before placing orders. ST products are sold pursuant to ST's terms and conditions of sale in place at the time of order acknowledgement.

Purchasers are solely responsible for the choice, selection, and use of ST products and ST assumes no liability for application assistance or the design of Purchasers' products.

No license, express or implied, to any intellectual property right is granted by ST herein.

Resale of ST products with provisions different from the information set forth herein shall void any warranty granted by ST for such product.

ST and the ST logo are trademarks of ST. All other product or service names are the property of their respective owners.

Information in this document supersedes and replaces information previously supplied in any prior versions of this document.

© 2017 STMicroelectronics – All rights reserved