

Customer Information Sheet

DRAWING No.: R6581-00 - R6585-00

IF IN DOUBT - ASK

©

NOT TO SCALE

THIRD ANGLE PROJECTION

ALL DIMENSIONS IN mm

NOTES:

1. ALL TOLERANCES ARE ± 0.50 UNLESS OTHERWISE STATED.
2. RECOMMENDED PANEL THICKNESS = 0.8 - 3.2mm.
3. TEMPERATURE RANGE = -40°C TO $+85^{\circ}\text{C}$.

PART No.	MOUNTING HOLE	DIM 'A'	DIM 'B'	DIM 'C'	DIM 'D'
R6581-00	$\varnothing 9.5\text{mm}$	10.57	$\varnothing 9.62$	$\varnothing 6.30$	$\varnothing 12.96$
R6582-00	$\varnothing 13.0\text{mm}$	10.50	$\varnothing 12.70$	$\varnothing 8.20$	$\varnothing 15.00$
R6583-00	$\varnothing 15.9\text{mm}$	10.50	$\varnothing 15.70$	$\varnothing 13.20$	$\varnothing 18.70$
R6584-00	$\varnothing 18.9\text{mm}$	10.50	$\varnothing 18.60$	$\varnothing 14.30$	$\varnothing 21.60$
R6585-00	$\varnothing 22.0\text{mm}$	11.50	$\varnothing 22.20$	$\varnothing 17.60$	$\varnothing 24.10$

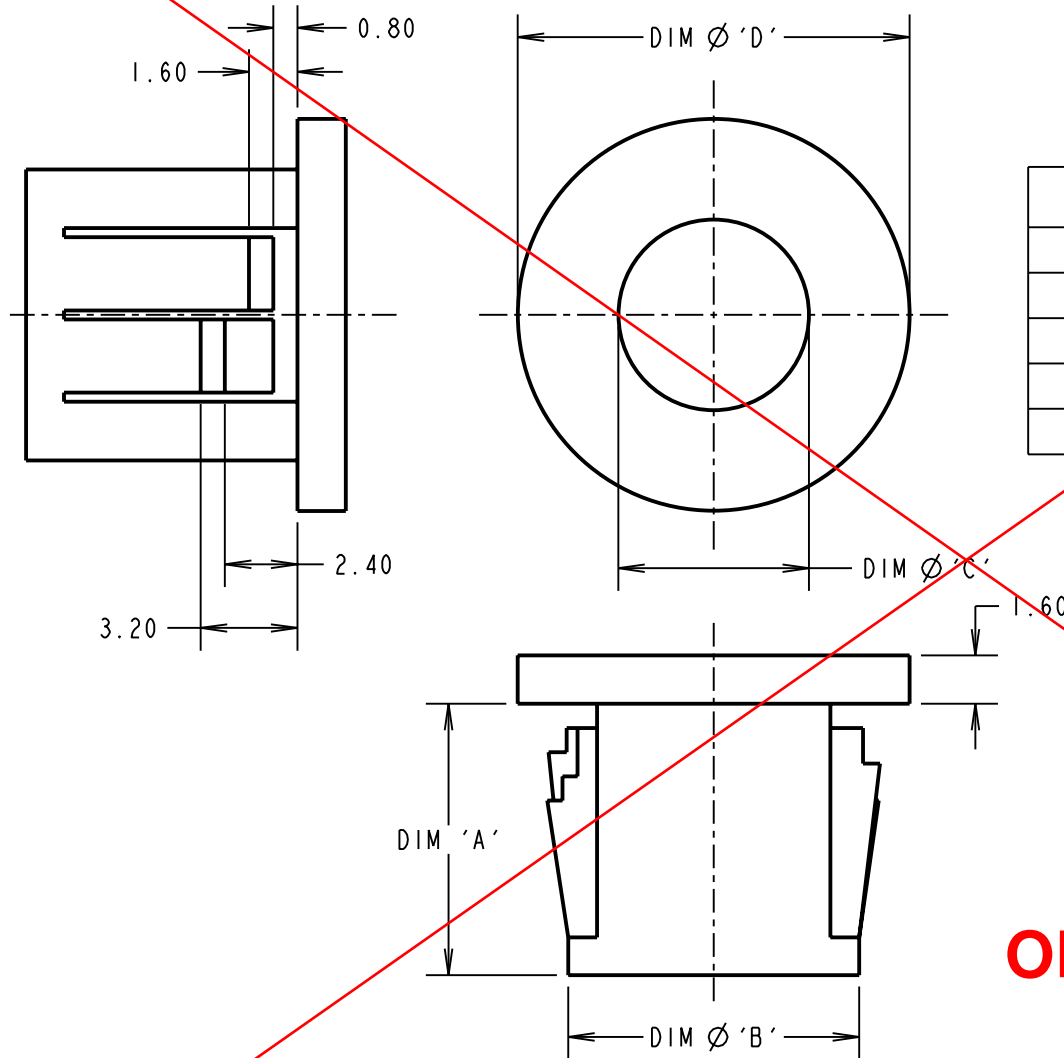

ORDER CODE:

R658X-00

SIZE CODE _____
(SEE TABLE)

CP	3	11.03.10	10702
NAME	ISS.	DATE	C/NOTE
APPROVED: C. PENROSE			
CHECKED: R. ADDE			
DRAWN: D. BECK			
CUSTOMER REF.:			
ASSEMBLY DRG:			

OBSOLETE

HARWIN

HARWIN USA TEL: 603 893 5376 FAX: 603 893 5396 mis@harwin.com	HARWIN Europe (UK) TEL: 023 9231 4545 FAX: 023 9231 4590 mis@harwin.co.uk	HARWIN Asia TEL: +65 6 779 4909 FAX: +65 6 779 3868 mis@harwin.com.sg
--	--	--

THIS DRAWING AND ANY INFORMATION OR DESCRIPTIVE MATTER SET OUT HEREON ARE CONFIDENTIAL AND COPYRIGHT PROPERTY OF THE HARWIN GROUP AND MUST NOT BE DISCLOSED, LOANED, COPIED OR USED FOR MANUFACTURING, TENDERING OR FOR ANY OTHER PURPOSE WITHOUT THEIR WRITTEN PERMISSION.

TOLERANCES
X = $\pm 1\text{mm}$
X.X = $\pm 0.25\text{mm}$
X.XX = $\pm 0.10\text{mm}$
X.XXX = $\pm 0.01\text{mm}$
ANGLES = $\pm 5^{\circ}$
UNLESS STATED

MATERIAL:
NYLON 66 BLACK UL94V-2

FINISH: CLEAN

S/AREA: mm²

TITLE:
SNAP-FIT BUSH

DRAWING NUMBER:
R6581-00 - R6585-00

SHT 2 OF 2