

REVISION			
REV.	DESCRIPTION	DATE	APPROVED

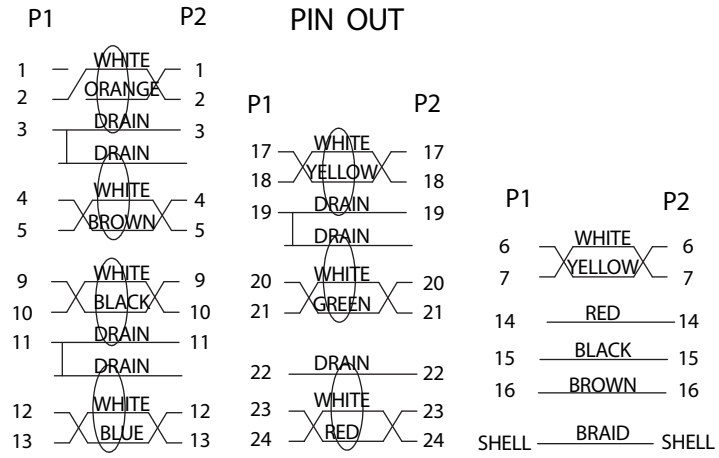
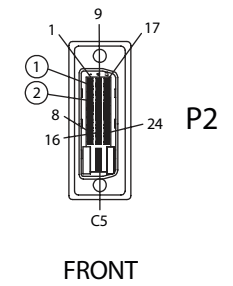
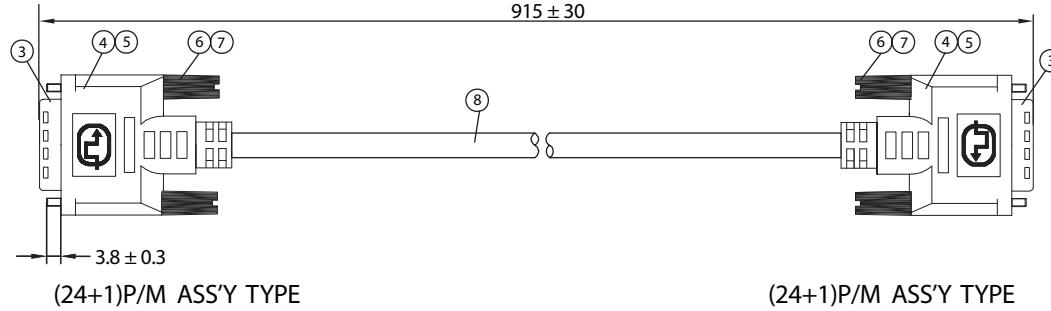
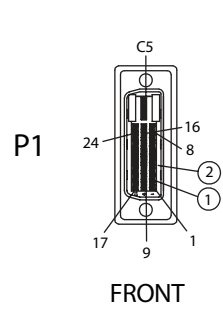
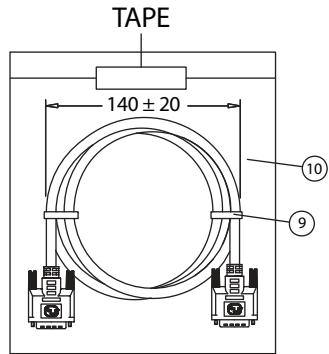

- NOTES:**
- CABLE: UL20276
28AWGx1P+DW+FOIL)x7+28AWGx3C+28AWGx1P+MYLAR+FOIL+BD
COLOR: BEIGE, OD: 8.5 ± 0.3mm
PRINTING: E166307 AWM 20276 28AWG 80°C VW-1
LOW VOLTAGE COMPUTER CABLE
 - CONNECTORS: DVI(24+1)P/M TO DVI(24+1)P/M
 - HOOD: ASS'Y TYPE, COLOR: BEIGE
 - ELECTRICAL TEST:
<1>.100% OPEN SHORT & MISS WIRE TEST
<2>.INSULATION RESISTANCE: DC400V 10M ohm MIN.
<3>.CONDUCTOR RESISTANCE: 3 ohm MAX.
 - PACKING: 1PC/POLYBAG

No.	PARTS NAME	SPECIFICATION STANDARD	QTY	REMARKS
①	DVI (24+1)P/M - CONTACT	BRASS / GOLD PLATED SOLDER TYPE	50	
②	DVI (24+1)P/M - INSULATOR	THERMOPLASTIC / BLACK UL94V-0	2	
③	DVI (24+1)P/M - SHELL	NICKEL PLATED	2	
④	CAN	STEEL TIN PLATED	2	
⑤	DVI (24+1)P/M - COVER	45P PVC/BEIGE(BK#01)	2	
⑥	THUMB SCREW	#4-40 2.8x44mm, NICKEL PLATED	4	
⑦	SCREW - MOLD	35P PVC / COLOR: BLACK	4	
⑧	CABLE DVI 24+1 UL 20276	KL 3007ABK01A	1	
⑨	MINI TIE	PE/BLACK	2	
⑩	POLYBAG	0.08x180x200	1	

Dim range (mm)	Tolerance +/- (mm)	Qualtek Electronics Corp. WCI DIVISION		
		Part Number: 1321008-03		
0-1	0.15	Description: DVI (24+1)P/M - DVI (24+1)P/M		
1-6	0.20			
6-18	0.30			
18-50	0.50			
50-120	0.70	Drawn / Date	Checked / Date	Approved / Date
120-250	0.90	B.Grubb 12-20-06	12-20-06	JJH / 12-20-06
250-500	1.20			