

REVISONS		DATE	BY	APPV
NO	DESCRIPTION			
N	REVISED PER ECO-15-016251	13NOV15	KG	CD

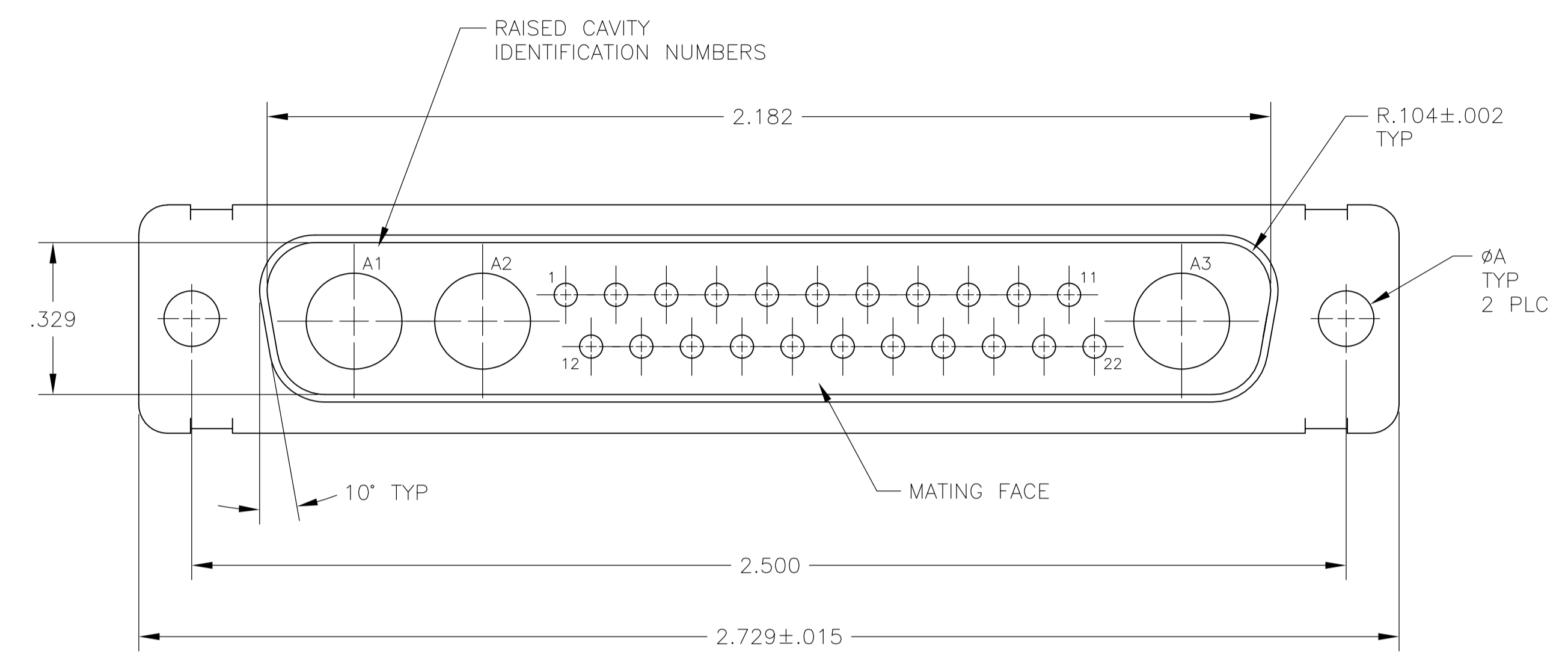

- THIS PLUG WILL MATE WITH ANY 25C3, SIZE 4 RECEPTACLE IN AMPLIMITE SERIES.
- MAXIMUM WIRE INSULATION TO BE USED WITH THIS PLUG IS ϕ .068.
- STAINLESS STEEL RETENTION CLIPS ARE INCLUDED IN INSERT ASSEMBLY.
- CONNECTOR SUPPLIED WITHOUT CONTACTS, SHOWN FOR ILLUSTRATION ONLY.
- INSERTION/EXTRACTION TOOL USED FOR SIZE 20 PIN SIGNAL CONTACTS IS 91067-2.
- USE 22 SIZE 20 SIGNAL CONTACTS, MILITARY P/N M39029/64-369, TE/MFG P/N 205089-1 OR ANY OF THE TE PRECISION FORMED SIZE 20 PINS FOR AMPLIMITE CONNECTORS.
- STEEL PER ASTM-A-109.
- CADMIUM PLATED PER QQ-P-416, TYPE II, CLASS 2.
- BRASS PER ASTM-B-36 AND MIL-C-50.
- FINISH: GOLD PLATED PER MIL-G-45204 TYPE II, GRADE C, OVER COPPER PLATE PER MIL-C-14550, CLASS IV.
- COPPER ALLOY RETENTION CLIPS ARE INCLUDED IN INSERT ASSEMBLY.
- USE 22 SIZE 20 SIGNAL CONTACTS, NASA PART NO. G-10-P1, TE/MFG PART NO. 205089-4.
- FINISH: TIN PER ASTM-B-545 .000400 MIN THK OVER COPPER PER AMS2418 .000050 MIN THK.
- GROUNDING INDENTS FOR 208742-4 & 5-208742-4 ONLY.
- FINISH: ZINC PLATE PER ASTM-B-633, .000200-.000400 THK WITH SUPPLEMENTARY CHROMATE (Cr3+)

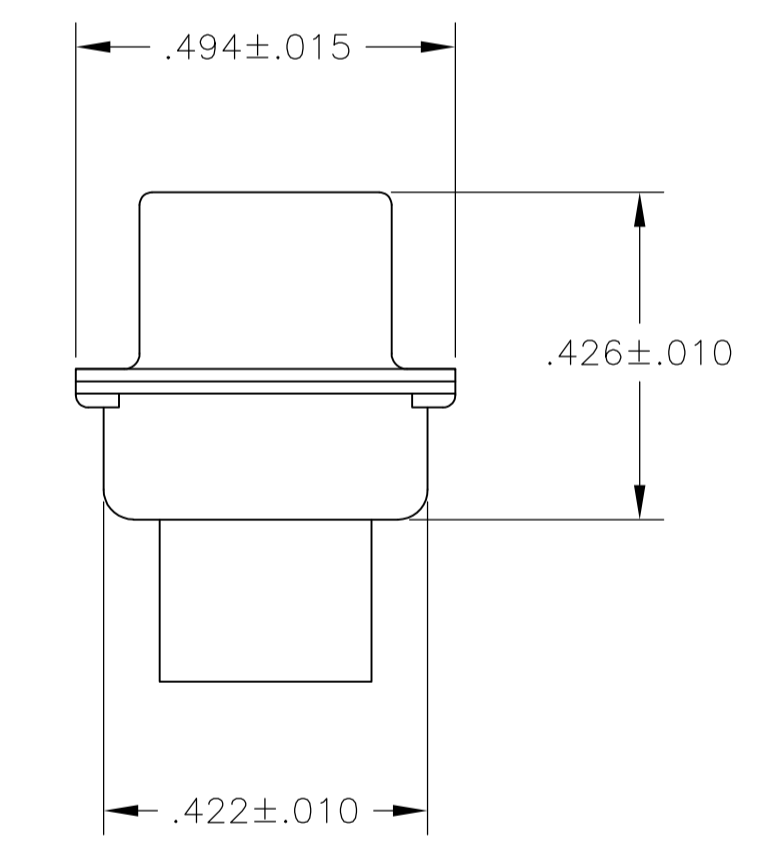
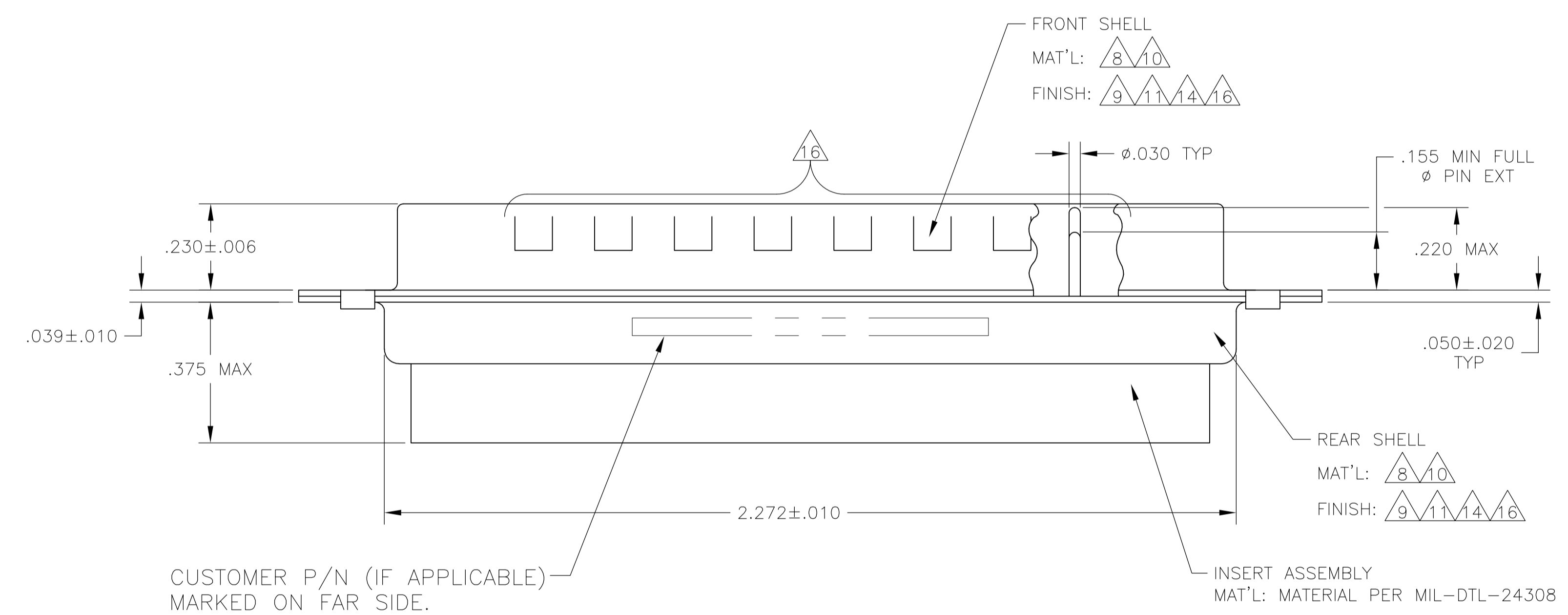

CUSTOMER P/N (IF APPLICABLE) MARKED ON FAR SIDE.
 MANUFACTURER'S NAME, BRAND OR LOGO AND MANUFACTURER'S PART NO AND DATE CODE MARKED ON NEAR SIDE

INSERT ASSEMBLY
 MAT'L: MATERIAL PER MIL-DTL-24308

REMARKS	CUSTOMER PART NO	ØA	DESCRIPTION	MFG'S PART NO.
\triangle 8 \triangle 15 \triangle 14	NOT APPLICABLE	.120	MIL-C-24308 EQUIVALENT	5-208742-4
\triangle 2 \triangle 6 \triangle 8 \triangle 16	NOT APPLICABLE	.120	MIL-C-24308 EQUIVALENT	5-208742-1
\triangle 8 \triangle 14 \triangle 15	NOT APPLICABLE	.120	MIL-C-24308 EQUIVALENT	208742-4
\triangle 10 \triangle 11 \triangle 12 \triangle 13	311P405-20P-B-15	.154	NON-MAGNETIC NASA QUALIFIED	208742-3
\triangle 10 \triangle 11 \triangle 12 \triangle 13	311P405-20P-B-12	.120	NON-MAGNETIC NASA QUALIFIED	208742-2
\triangle 2 \triangle 6 \triangle 8 \triangle 9	NOT APPLICABLE	.120	MIL-C-24308 EQUIVALENT	208742-1

THIS DRAWING IS A CONTROLLED DOCUMENT.

DIMENSIONS: INCHES 0 PLC ± - 1 PLC ± - 2 PLC ± - 3 PLC ± .005(0.13) 4 PLC ± - ANGLES ± # 0',30'	TOLERANCES UNLESS OTHERWISE SPECIFIED: 0 PLC ± - 1 PLC ± - 2 PLC ± - 3 PLC ± .005(0.13) 4 PLC ± - ANGLES ± # 0',30'	DRAWING NO: 00779 CUSTOMER DRAWING	DATE: 27-May-15 NAME: CHARLES THOMAS PRODUCT SPEC: PLUG ASSEMBLY AMPLIMITE 25C3 SIZE 4, COAX MIX SCALE: 4:1	SHEET: 1 OF 1 REV: N
---	---	---------------------------------------	--	-------------------------