

10 9 8 7 6 5 4 3 2 1

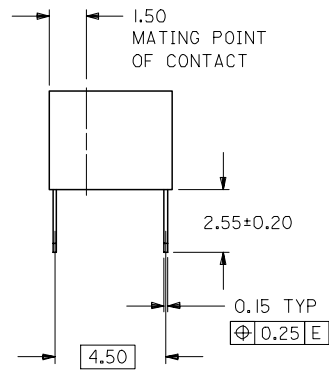
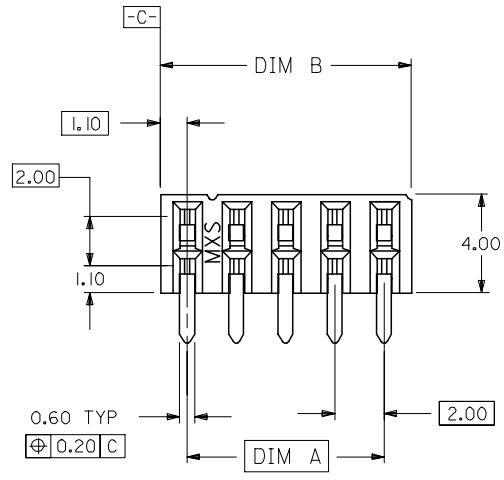

PART NO. LEGEND

87264- * * 5 *
CIRCUIT SIZE PLATING

POST-PLATED

- 0 - 0.38um/15uin MIN. GOLD PLATE IN SELECTED AREA AND 2.54um/100uin MIN. TIN/LEAD IN SELECTED AREA OVER 1.27um/50uin NICKEL OVERALL (IN TUBE).
- 1 - 0.76um/30uin MIN. GOLD PLATE IN SELECTED AREA AND 1.90um/75uin MIN. TIN/LEAD IN SELECTED AREA OVER 1.27um/50uin NICKEL OVERALL (IN TUBE).
- 2 - 0.38um/15uin MIN. GOLD PLATE IN SELECTED AREA AND 2.54um/100uin MIN. TIN IN SELECTED AREA OVER 1.27um/50uin NICKEL OVERALL (IN TUBE).
- 3 - 0.76um/30uin MIN. GOLD PLATE IN SELECTED AREA AND 2.54um/100uin MIN. TIN IN SELECTED AREA OVER 1.27um/50uin NICKEL OVERALL (IN TUBE).
- 6 - 0.38um/15uin MIN. GOLD PLATE IN SELECTED AREA AND 2.54um/100uin MIN. TIN/LEAD IN SELECTED AREA OVER 1.27um/50uin NICKEL OVERALL. (IN TAPE/REEL)
- 7 - 0.76um/30uin MIN. GOLD PLATE IN SELECTED AREA AND 2.54um/100uin MIN. TIN/LEAD IN SELECTED AREA OVER 1.27um/50uin NICKEL OVERALL. (IN TAPE/REEL)
- 8 - 0.38um/15uin MIN. GOLD PLATE IN SELECTED AREA AND 2.54um/100uin MIN. TIN IN SELECTED AREA OVER 1.27um/50uin NICKEL OVERALL. (IN TAPE/REEL)
- 9 - 0.76um/30uin MIN. GOLD PLATE IN SELECTED AREA AND 2.54um/100uin MIN. TIN IN SELECTED AREA OVER 1.27um/50uin NICKEL OVERALL. (IN TAPE/REEL)

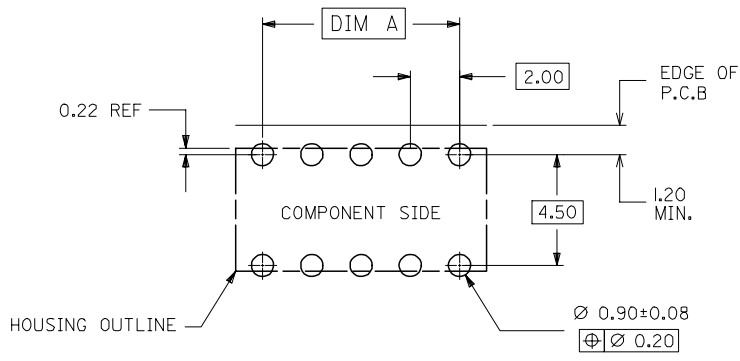
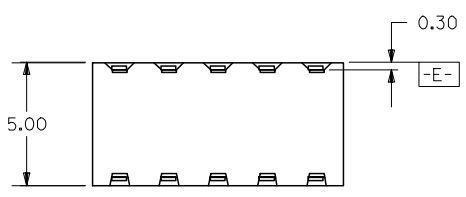

RECOMMENDED P.C. BOARD LAYOUT

NOTES:

1. IO CIRCUIT SIZE SHOWN FOR ILLUSTRATION ONLY. SEE CHART FOR AVAILABLE PART SIZES.
2. PLATING FINISH : TERMINAL - AS PER LEGEND
3. RECOMMENDED PC BOARD THICKNESS IS 1.60 +/- 0.10mm.
4. PRODUCT SPECIFICATION PS-87264 APPLIES.
5. PART IS MATEABLE TO ALL MILLI-GRID HEADERS WITH MATING PIN LENGTH BETWEEN 2.50mm AND 4.20mm.
6. TAPE & REEL OPTION IS SHOWN ON SHT 3 WITH 8 CKT ILLUSTRATION.

UPDATE REVISION	2005/10/19	2005/11/05
EC NO: S2005-0714	DRWN:KSE	CHKD:BLW
	2005/10/19	2005/11/05
	APPR:PTL	IM
D2	REV	DESCRIPTION

QUALITY SYMBOLS	▽=0
	△=0

GENERAL TOLERANCES (UNLESS SPECIFIED)	mm	INCH
	4 PLACES ± ---	± ---
	3 PLACES ± ---	± ---
	2 PLACES ± 0.2	± ---
	1 PLACE ± ---	± ---
ANGULAR ± 3 °		
DRAFT WHERE APPLICABLE MUST REMAIN WITHIN DIMENSIONS		

DIMENSION STYLE MM ONLY	
DRAWN BY	DATE
JWAN	1992/02/25
CHECKED BY	DATE
MLA1	1992/02/25
APPROVED BY	DATE
RWONG	1992/02/25
MATERIAL NO.	DOCUMENT NO.
SEE TABLE	SD-87264-**50
SIZE A3	THIS DRAWING CONTAINS INFORMATION THAT IS PROPRIETARY TO MOLEX INCORPORATED AND SHOULD NOT BE USED WITHOUT WRITTEN PERMISSION

SCALE NTS	DESIGN UNITS METRIC	THIRD ANGLE PROJECTION
SALES DRAWING		
MGRID, 2MM DUAL ROW HDR.		
SIDE ENTRY RECEPT., T/H		
MOLEX MOLEX INCORPORATED		
SHEET NO.	1 OF 3	

9 8 7 6 5 4 3 2 1

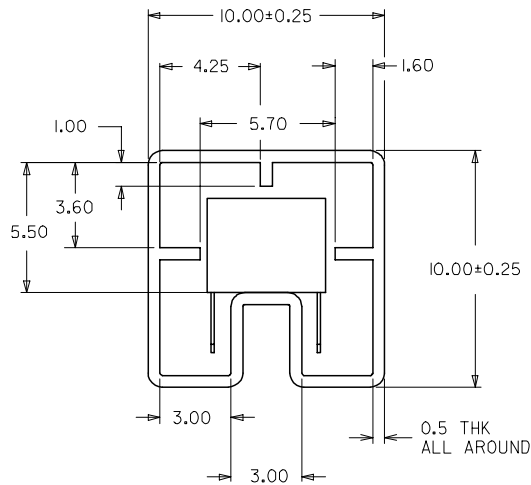
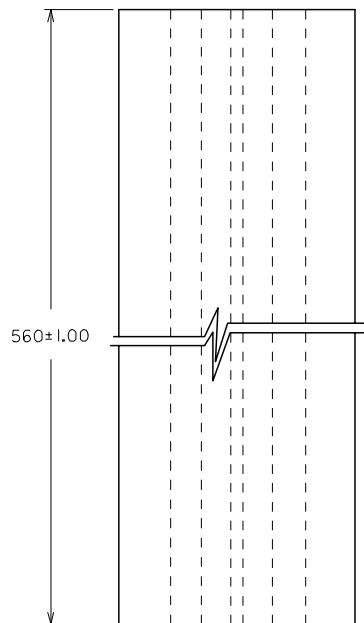

PART IN TUBE ORIENTATION.

PART NUMBER 0.38um GOLD PLATING \triangle_2	PART NUMBER 0.76um GOLD PLATING \triangle_2	CKT. SIZE	DIM A	DIM B
87264-065*	87264-065*	6	4.00	6.20
87264-085*	87264-085*	8	6.00	8.20
87264-105*	87264-105*	10	8.00	10.20
87264-125*	87264-125*	12	10.00	12.20
87264-145*	87264-145*	14	12.00	14.20
87264-165*	87264-165*	16	14.00	16.20
87264-185*	87264-185*	18	16.00	18.20
87264-205*	87264-205*	20	18.00	20.20
87264-225*	87264-225*	22	20.00	22.20
87264-245*	87264-245*	24	22.00	24.20
87264-265*	87264-265*	26	24.00	26.20
87264-285*	87264-285*	28	26.00	28.20
87264-305*	87264-305*	30	28.00	30.20
87264-325*	87264-325*	32	30.00	32.20
87264-345*	87264-345*	34	32.00	34.20
87264-365*	87264-365*	36	34.00	36.20
87264-385*	87264-385*	38	36.00	38.20
87264-405*	87264-405*	40	38.00	40.20
87264-425*	87264-425*	42	40.00	42.20
87264-445*	87264-445*	44	42.00	44.20
87264-465*	87264-465*	46	44.00	46.20
87264-485*	87264-485*	48	46.00	48.20
87264-505*	87264-505*	50	48.00	50.20

UPDATE REVISION EC NO: S2005-0714 2005/10/19 DRWN:KSEE CHKD:BLW 2005/10/19 APPR:PTLIM 2005/11/05 D2	DESCRIPTION REV	QUALITY SYMBOLS	GENERAL TOLERANCES (UNLESS SPECIFIED)	DIMENSION STYLE	SCALE	DESIGN UNITS	THIRD ANGLE PROJECTION															
		$\nabla=0$ $\triangle=0$	<table border="1"> <thead> <tr> <th></th> <th>mm</th> <th>INCH</th> </tr> </thead> <tbody> <tr><td>4 PLACES</td><td>± ---</td><td>± ---</td></tr> <tr><td>3 PLACES</td><td>± ---</td><td>± ---</td></tr> <tr><td>2 PLACES</td><td>± 0.2</td><td>± ---</td></tr> <tr><td>1 PLACE</td><td>± ---</td><td>± ---</td></tr> </tbody> </table>		mm	INCH	4 PLACES	± ---	± ---	3 PLACES	± ---	± ---	2 PLACES	± 0.2	± ---	1 PLACE	± ---	± ---	MM ONLY	NTS	METRIC	
			mm	INCH																		
		4 PLACES	± ---	± ---																		
3 PLACES	± ---	± ---																				
2 PLACES	± 0.2	± ---																				
1 PLACE	± ---	± ---																				
	ANGULAR ± 3°	DRAWN BY JWAN DATE 1992/02/25 CHECKED BY MLA1 DATE 1992/02/25 APPROVED BY RWONG DATE 1992/02/25	TITLE	SALES DRAWING MGRID, 2MM DUAL ROW HDR. SIDE ENTRY RECEPT., T/H MOLEX INCORPORATED																		
	DRAFT WHERE APPLICABLE MUST REMAIN WITHIN DIMENSIONS	SIZE	SEE TABLE	DOCUMENT NO.	SD-87264-**50		SHEET NO. 2 OF 3															

PART NUMBER 0.38um GOLD PLATING \triangle_2 (IN TAPE/REEL)	PART NUMBER 0.76um GOLD PLATING \triangle_2 (IN TAPE/REEL)	CKT SIZE	DIM W	DIM F	DIM Bo
87264-085*	87264-085*	8	24.00	11.50	8.80

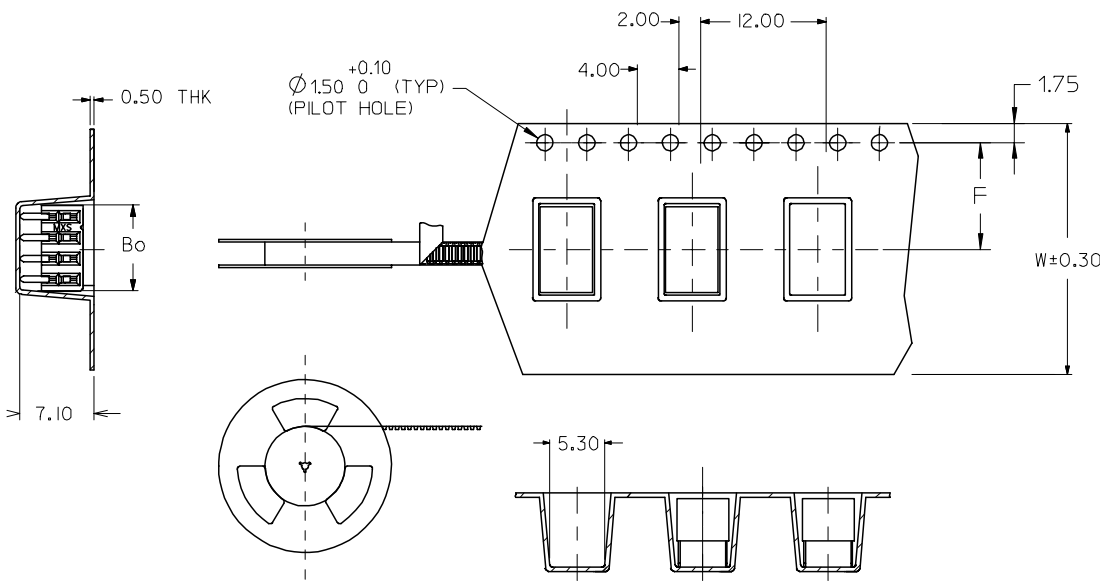

NOTES:

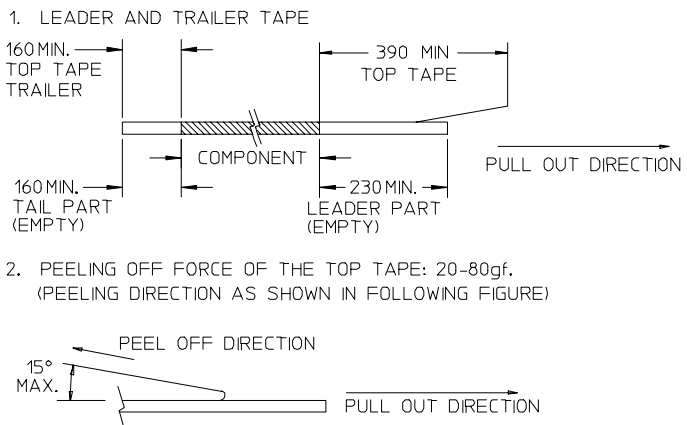

- 1. LEADER AND TRAILER TAPE
- 2. PEELING OFF FORCE OF THE TOP TAPE: 20-80gf.
(PEELING DIRECTION AS SHOWN IN FOLLOWING FIGURE)
- 3. PACKAGING STANDARD IS AS PER EIA-481.
- 4. TAPE & REEL QUANTITY = 600PCS/REEL

CUSTOMER PULL OUT DIRECTION →

ADD LEADER & TRAILER EC NO: S2005-0714 DRWN:KSEE CHKD:BLW APPR:PTLIM	2005/10/19 2005/10/19 2005/11/05	QUALITY SYMBOLS $\nabla=0$ $\triangle=0$	GENERAL TOLERANCES (UNLESS SPECIFIED)		DIMENSION STYLE MM ONLY	SCALE NTS	DESIGN UNITS METRIC	THIRD ANGLE PROJECTION		
	DESCRIPTION		mm	INCH	DRAWN BY	DATE	TITLE SALES DRAWING MGRID, 2MM DUAL ROW HDR. SIDE ENTRY RECEPT., T/H			
	REV		± ---	± ---	JWAN	1992/02/25				
	D2		4 PLACES	± ---	± ---	CHECKED BY	DATE	MOLEX INCORPORATED DOCUMENT NO. SD-87264-**50 SHEET NO. 3 OF 3		
	3 PLACES	± ---	± ---	MLA1	1992/02/25					
	2 PLACES	± 0.2	± ---	APPROVED BY	DATE	THIS DRAWING CONTAINS INFORMATION THAT IS PROPRIETARY TO MOLEX INCORPORATED AND SHOULD NOT BE USED WITHOUT WRITTEN PERMISSION				
	1 PLACE	± ---	± ---	RWONG	1992/02/25					
		ANGULAR ± 3 °		MATERIAL NO.						
		DRAFT WHERE APPLICABLE MUST REMAIN WITHIN DIMENSIONS		SIZE						